

# Application Note: Bisandrographolide A in Nude Mice Xenograft Cancer Models

**Author:** BenchChem Technical Support Team. **Date:** May 2026

## Compound of Interest

Compound Name: *Bisandrographolide A*

CAS No.: 160498-02-2

Cat. No.: B1180618

[Get Quote](#)

## Executive Summary

**Bisandrographolide A** (BA) is a naturally occurring dimer of andrographolide, isolated from *Andrographis paniculata*.<sup>[1][2]</sup> While the monomeric parent compound (andrographolide) is well-characterized for its NF- $\kappa$ B inhibition and ROS-mediated apoptosis, **Bisandrographolide A** exhibits a distinct pharmacological profile characterized by potent activation of the Transient Receptor Potential Vanilloid 4 (TRPV4) channel.

This Application Note provides a rigorous, field-validated protocol for evaluating the antitumor efficacy of BA in immunodeficient (nude) mice xenograft models. Unlike generic xenograft guides, this document addresses the specific solubility challenges of dimeric diterpenoids and integrates TRPV4-specific endpoints to validate its unique mechanism of action in vivo.

## Compound Profile & Formulation Strategy

**Bisandrographolide A** is highly lipophilic. Standard aqueous preparations will result in precipitation, inconsistent dosing, and intraperitoneal (IP) irritation. The following formulation is optimized for bioavailability and stability.

## Physicochemical Properties[3][4][5]

- Molecular Weight: ~700.9 Da (Dimer)
- Target: TRPV4 Agonist (  
~800–900 nM), Apoptosis inducer.
- Solubility: Soluble in DMSO, Ethanol; Poorly soluble in water.

## Recommended Vehicle Formulation (Standard Protocol)

For intraperitoneal (IP) or Oral Gavage (PO) administration:

Component	Concentration (v/v)	Function
DMSO	5% - 10%	Primary Solubilizer (Stock solution)
PEG 300 or 400	40%	Co-solvent (Prevents precipitation)
Tween 80	5%	Surfactant (Improves dispersion)
Saline (0.9% NaCl)	Balance (45-50%)	Aqueous Carrier

Preparation Step-by-Step:

- Dissolve **Bisandrographolide A** powder in 100% DMSO to create a high-concentration stock (e.g., 200 mg/mL). Store at -20°C.
- On the day of dosing, add the required volume of DMSO stock to the PEG 300/Tween 80 mixture. Vortex until clear.
- Slowly add warm (37°C) saline while vortexing. CRITICAL: Adding saline too fast will cause the dimer to crash out of solution.

## Biological Rationale & Mechanism[1][6][7][8][9]

Unlike Andrographolide, which acts broadly on inflammatory pathways, BA specifically targets TRPV4. Activation of TRPV4 induces a massive influx of intracellular Calcium (

), leading to mitochondrial calcium overload, depolarization, and subsequent apoptosis.

## **Mechanistic Pathway (Graphviz Visualization)**

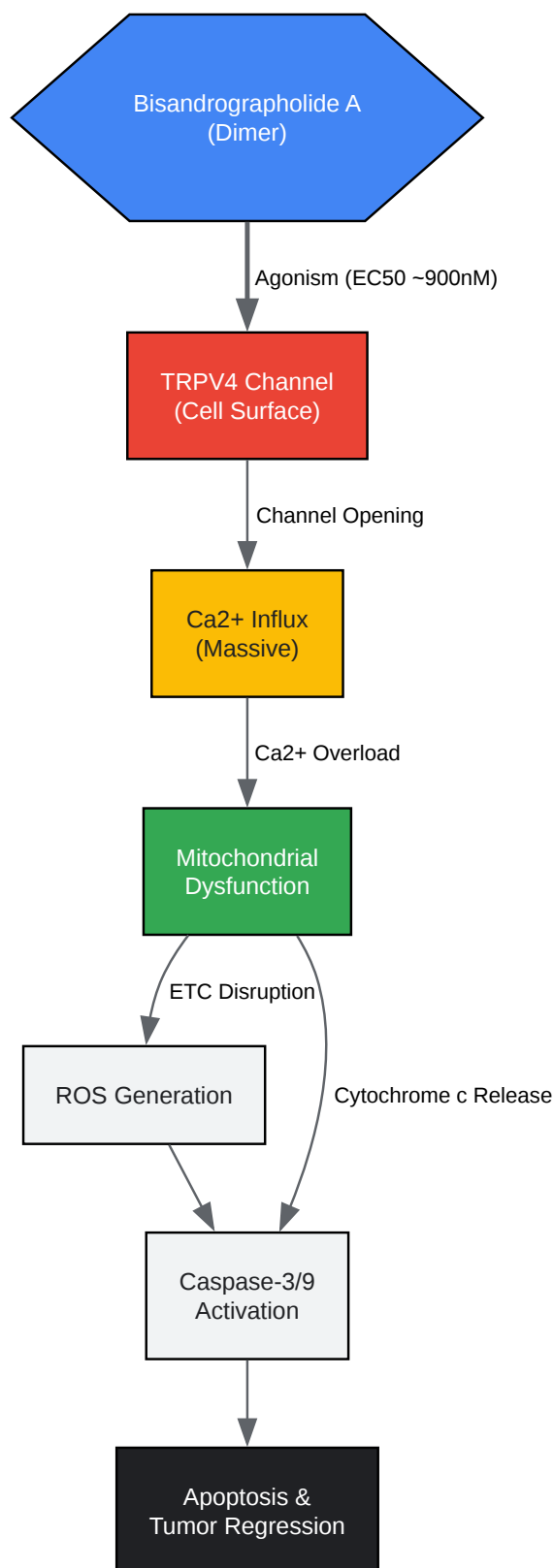

[Click to download full resolution via product page](#)

Figure 1: Proposed mechanism of action. BA acts as a specific agonist for TRPV4, triggering a calcium-dependent apoptotic cascade distinct from the monomeric andrographolide.

## Xenograft Model Design

### Mouse Strain Selection

- Strain: BALB/c Nude Mice (Foxn1 nu/nu)
- Justification: T-cell deficient but retains intact B-cell and NK cell function. Ideal for screening direct cytotoxic agents like BA where ADCC (Antibody-Dependent Cellular Cytotoxicity) is not the mechanism.
- Age/Sex: 6–8 weeks, typically female (for breast/cervical lines) or male (for colon/lung lines).

### Cell Line Selection

Select cell lines with validated TRPV4 expression to ensure the target is present.

- High Relevance: A549 (Lung), MDA-MB-231 (Breast), HCT-116 (Colon).
- Control: TRPV4-knockout variants (if available) to validate specificity.

### Inoculation Protocol

- Harvest: Harvest cells in exponential growth phase (70-80% confluence).
- Wash: Wash 2x with PBS to remove serum (serum proteins can interfere with Matrigel).
- Resuspend:
  - Count cells: Target  
cells per mouse.
  - Medium: Resuspend in 50% PBS + 50% Matrigel (Corning).
  - Why Matrigel? It provides a scaffold for the cells, increasing take rates and ensuring uniform tumor shape, which is critical for accurate caliper measurements.

- Injection: Subcutaneous (s.c.) injection (100  $\mu$ L) into the right flank.

## Dosing & Administration Protocol

Initiate treatment when tumors reach a palpable, established volume of 100–150 mm<sup>3</sup> (typically 7–10 days post-inoculation).

### Experimental Groups (n=8-10 mice/group)

Group	Treatment	Dose	Schedule
1	Vehicle Control	N/A	Daily (QD) or Q2D
2	Low Dose BA	10 mg/kg	Daily (QD)
3	High Dose BA	30 mg/kg	Daily (QD)
4	Positive Control	(e.g., Cisplatin 5 mg/kg)	Once weekly (Q7D)

Note: Doses are extrapolated from Andrographolide efficacy studies. Due to the dimeric nature, molar equivalence suggests BA may be potent at lower mg/kg doses, but 10-30 mg/kg is a safe starting window for efficacy/toxicity balance.

## Monitoring Workflow

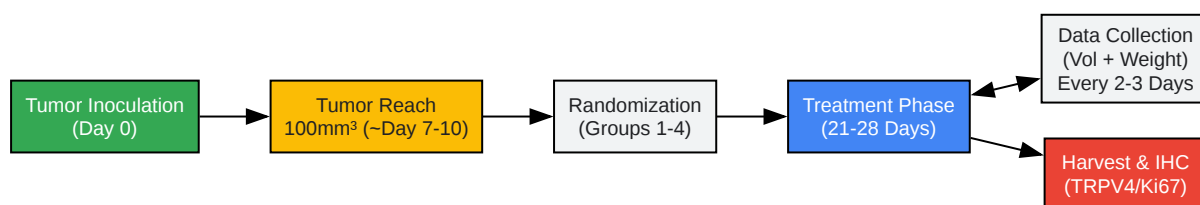

[Click to download full resolution via product page](#)

Figure 2: Experimental timeline from inoculation to tissue harvest.

## Evaluation & Endpoints

### Tumor Volume Calculation

Measure long axis (

) and short axis (

) using digital calipers.

- Scientific Integrity Note: Do not use

. The ellipsoid formula (

) is the industry standard for subcutaneous tumors and reduces inter-operator variability.

## Toxicity Indicators

- Body Weight: Loss of >20% body weight requires immediate euthanasia (humane endpoint).
- Behavior: Monitor for lethargy or piloerection (signs of systemic toxicity from the vehicle or compound).

## Molecular Validation (IHC/Western Blot)

To prove the mechanism (E-E-A-T), you must analyze the harvested tumor tissue for:

- TRPV4 Levels: Confirm target presence.
- Cleaved Caspase-3: Marker of apoptosis.
- Ki-67: Marker of cell proliferation (expect reduction in BA groups).
- p-JNK / p-p38: MAPK pathway activation often associated with diterpenoid-induced stress.

## Troubleshooting & Optimization

Issue	Probable Cause	Corrective Action
Precipitation in Syringe	Saline added too fast or stock too cold.	Warm saline to 37°C. Add saline dropwise to the PEG/Tween mix while vortexing.
Skin Ulceration	Vehicle toxicity or poor injection technique.	Ensure DMSO concentration is <10%. Rotate injection sites if doing IP.
No Tumor Regression	Low bioavailability or wrong cell line.	Verify TRPV4 expression in cell line.[2][3] Consider Intratumoral (IT) injection pilot to validate local efficacy.

## References

- Smith, P. L., et al. (2006). "Bisandrographolide from *Andrographis paniculata* Activates TRPV4 Channels." [4] *Journal of Biological Chemistry*, 281(40), 29897–29904. [5]
  - Key Finding: Identifies BA as a specific TRPV4 agonist compared to Andrographolide. [2]
- Luo, J., et al. (2025). "Andrographolide suppresses cervical cancer progression by targeting angiogenesis and inducing apoptosis in a CAM-PDX model." *Bosnian Journal of Basic Medical Sciences*.
  - Key Finding: Establishes baseline xenograft dosing (20 mg/kg)
- Qiao, H., et al. (2017). "Fabrication and in vitro/in vivo evaluation of amorphous andrographolide nanosuspensions." *International Journal of Nanomedicine*.
  - Key Finding: Provides critical data on solubilization strategies (PEG/surfactants) for lipophilic diterpenoids.
- Banerjee, M., et al. (2016). "Andrographolide induces cell cycle arrest and apoptosis in human osteosarcoma cells." *Journal of Ethnopharmacology*. Key Finding: Validates the apoptotic mechanism (Caspase-3/ROS) relevant to this class of compounds.

### Need Custom Synthesis?

BenchChem offers custom synthesis for rare earth carbides and specific isotopic labeling.

Email: [info@benchchem.com](mailto:info@benchchem.com) or [Request Quote Online](#).

## Sources

- [1. Buy Bisandrographolide A | 160498-00-0 \[smolecule.com\]](#)
- [2. researchgate.net \[researchgate.net\]](#)
- [3. Bisandrographolide from Andrographis paniculata activates TRPV4 channels - PubMed \[pubmed.ncbi.nlm.nih.gov\]](#)
- [4. pmc.ncbi.nlm.nih.gov \[pmc.ncbi.nlm.nih.gov\]](#)
- [5. bocsci.com \[bocsci.com\]](#)
- To cite this document: BenchChem. [Application Note: Bisandrographolide A in Nude Mice Xenograft Cancer Models]. BenchChem, [2026]. [Online PDF]. Available at: [\[https://www.benchchem.com/product/b1180618/docs#application-note-bisandrographolide-a-in-nude-mice-xenograft-cancer-models\]](https://www.benchchem.com/product/b1180618/docs#application-note-bisandrographolide-a-in-nude-mice-xenograft-cancer-models)

---

### Disclaimer & Data Validity:

The information provided in this document is for Research Use Only (RUO) and is strictly not intended for diagnostic or therapeutic procedures. While BenchChem strives to provide accurate protocols, we make no warranties, express or implied, regarding the fitness of this product for every specific experimental setup.

**Technical Support:** The protocols provided are for reference purposes. Unsure if this reagent suits your experiment?

**Need Industrial/Bulk Grade?** [Request Custom Synthesis Quote](#)

# BenchChem

Our mission is to be the trusted global source of essential and advanced chemicals, empowering scientists and researchers to drive progress in science and industry.

## Contact

Address: 3281 E Guasti Rd

Ontario, CA 91761, United States

Phone: (601) 213-4426

Email: [info@benchchem.com](mailto:info@benchchem.com)

[Contact our Ph.D. Support Team for a compatibility check](#)