

Technical Support Center: Mitigating TRAP-5 Amide-Induced Receptor Internalization

Author: BenchChem Technical Support Team. **Date:** April 2026

Compound of Interest

Compound Name: TRAP-5 amide

Cat. No.: B118074

[Get Quote](#)

This technical support center provides troubleshooting guides and frequently asked questions (FAQs) for researchers, scientists, and drug development professionals working to mitigate **TRAP-5 amide**-induced internalization of its receptor, Proteinase-Activated Receptor 1 (PAR1).

Frequently Asked Questions (FAQs)

Q1: What is **TRAP-5 amide** and what is its receptor?

TRAP-5 (Thrombin Receptor Activator for Peptide 5) is a synthetic peptide agonist that mimics the action of thrombin on Proteinase-Activated Receptor 1 (PAR1), a G protein-coupled receptor (GPCR). It is commonly used in research to study PAR1 signaling and trafficking.

Q2: What is the mechanism of **TRAP-5 amide**-induced PAR1 internalization?

TRAP-5 amide binding to PAR1 induces a rapid, clathrin- and dynamin-dependent endocytosis. Unlike many other GPCRs, PAR1 internalization is notably independent of β -arrestin. The process involves receptor phosphorylation and ubiquitination, which serve as signals for recognition by adaptor proteins like AP-2 and Epsin-1, targeting the receptor to clathrin-coated pits for internalization.

Q3: Why would I want to mitigate **TRAP-5 amide**-induced PAR1 internalization?

Mitigating PAR1 internalization can be crucial for several research and drug development purposes:

- **Prolonging Cell Surface Signaling:** Preventing internalization can extend the duration of PAR1 signaling at the plasma membrane, which may be desirable for studying specific signaling pathways or for therapeutic applications where sustained surface receptor activity is beneficial.
- **Studying Biased Agonism:** By modulating internalization, researchers can investigate biased signaling, where an agonist preferentially activates one signaling pathway over another.
- **Drug Discovery:** Screening for compounds that inhibit internalization can lead to the discovery of novel allosteric modulators of PAR1 with unique therapeutic properties.

Q4: What are the key molecular players involved in PAR1 internalization that can be targeted for mitigation?

The key proteins that can be targeted to inhibit **TRAP-5 amide**-induced PAR1 internalization are:

- **Dynamin:** A GTPase essential for the scission of clathrin-coated vesicles from the plasma membrane.
- **Adaptor Protein 2 (AP-2):** A key adaptor protein that links PAR1 to the clathrin machinery.
- **Epsin-1:** An endocytic adaptor protein that recognizes ubiquitinated PAR1.

Troubleshooting Guides

Problem 1: Excessive or rapid PAR1 internalization in my experiments.

Possible Cause 1: High concentration of **TRAP-5 amide**.

- **Solution:** Perform a dose-response curve to determine the optimal concentration of **TRAP-5 amide** for your specific cell type and assay. Use the lowest concentration that elicits the

desired signaling response without causing maximal internalization.

Possible Cause 2: Cell type-specific differences in internalization machinery.

- Solution: Characterize the internalization kinetics in your specific cell line. Some cell lines may have higher expression levels of endocytic proteins, leading to more efficient internalization. Consider using a different cell line if the internalization rate is problematic for your experimental goals.

Possible Cause 3: Experimental conditions favoring endocytosis.

- Solution: Ensure that your experimental buffer and temperature are not inadvertently promoting endocytosis. For example, some serum components can enhance internalization. Consider using serum-free media during the **TRAP-5 amide** stimulation.

Problem 2: My inhibitor is not effectively blocking PAR1 internalization.

Possible Cause 1: Inappropriate inhibitor concentration.

- Solution: Consult the literature for the recommended concentration range for the specific inhibitor and cell type. Perform a dose-response experiment to determine the optimal inhibitory concentration (e.g., IC50) in your system. Refer to the data table below for guidance.

Possible Cause 2: Insufficient pre-incubation time with the inhibitor.

- Solution: Most inhibitors require a pre-incubation period to enter the cells and reach their target. Optimize the pre-incubation time before adding **TRAP-5 amide**. A typical starting point is 30 minutes.[1]

Possible Cause 3: The chosen inhibitor targets a pathway not central to PAR1 internalization.

- Solution: Confirm that your inhibitor targets a key component of the PAR1 internalization pathway (dynamin, AP-2). Since PAR1 internalization is β -arrestin independent, inhibitors targeting β -arrestin recruitment may not be effective.

Possible Cause 4: Off-target effects or inhibitor instability.

- Solution: Verify the specificity and stability of your inhibitor. Consider using a more specific or stable analog if available (e.g., Dyngo-4a as a more potent alternative to Dynasore).[2] Always include appropriate vehicle controls in your experiments.

Problem 3: High background or variability in my internalization assay.

Possible Cause 1: Non-specific binding of antibodies or ligands in imaging or binding assays.

- Solution:
 - Blocking: Use an appropriate blocking buffer (e.g., BSA or serum) to reduce non-specific binding.
 - Washing: Increase the number and duration of washing steps.
 - Antibody/Ligand Concentration: Titrate your primary and secondary antibodies or fluorescent ligands to find the optimal concentration that gives a good signal-to-noise ratio.
 - Fc Receptor Blocking: If using antibodies, consider using an Fc receptor blocking agent to prevent non-specific binding to Fc receptors on the cell surface.[3]

Possible Cause 2: Cell health and density.

- Solution:
 - Ensure cells are healthy and not overgrown, as this can affect receptor expression and internalization.
 - Plate cells at a consistent density for all experiments to minimize variability.

Possible Cause 3: Inconsistent timing of experimental steps.

- Solution: Standardize all incubation times, washing steps, and reagent additions across all samples and experiments.

Data Presentation: Inhibitors of PAR1 Internalization

Inhibitor	Target	Mechanism of Action	Typical Working Concentration	IC50	Reference
Dynasore	Dynamin-1 and -2	Non-competitive inhibitor of dynamin's GTPase activity, preventing vesicle scission.	30-80 μM	$\sim 15 \mu\text{M}$ (in vitro)	[4][5]
Dyngo-4a	Dynamin-1 and -2	A more potent and less cytotoxic analog of Dynasore.	5-30 μM	0.38 μM (Dynamin-1, in vitro)	
Barbadin	AP-2/ β -arrestin interaction	Selectively inhibits the interaction between the $\beta 2$ -adaplin subunit of AP2 and β -arrestin. Its effect on PAR1 is likely through AP-2 inhibition.	50-100 μM	Not reported for PAR1	
Mdivi-1	Drp1 (primary), Dynamin-related	Inhibits the GTPase activity of Drp1, a dynamin-	50 μM	Not reported for PAR1	

related
protein
involved in
mitochondrial
fission, but
has also
been shown
to affect
endocytosis.

Experimental Protocols

Protocol 1: Inhibition of TRAP-5 Amide-Induced PAR1 Internalization using a Dynamin Inhibitor (e.g., Dyngo-4a)

Objective: To quantitatively assess the inhibition of **TRAP-5 amide**-induced PAR1 internalization using a dynamin inhibitor.

Materials:

- Cells expressing PAR1 (e.g., HeLa or HEK293 cells)
- **TRAP-5 amide**
- Dyngo-4a (or Dynasore)
- Cell culture medium (serum-free for stimulation)
- Phosphate-buffered saline (PBS)
- Fixation solution (e.g., 4% paraformaldehyde in PBS)
- Primary antibody against an extracellular epitope of PAR1
- Fluorescently labeled secondary antibody

- Microplate reader, flow cytometer, or confocal microscope

Procedure:

- Cell Seeding: Seed PAR1-expressing cells in a suitable format (e.g., 96-well plate for ELISA or flow cytometry, or glass-bottom dishes for microscopy).
- Inhibitor Pre-incubation:
 - Wash the cells once with serum-free medium.
 - Add serum-free medium containing the desired concentration of Dyngo-4a (e.g., 30 μ M) or vehicle control (e.g., DMSO).
 - Incubate for 30 minutes at 37°C.
- **TRAP-5 Amide** Stimulation:
 - Add **TRAP-5 amide** to the desired final concentration directly to the wells containing the inhibitor.
 - Incubate for the desired time to induce internalization (e.g., 15-30 minutes at 37°C).
- Detection of Surface PAR1:
 - For Cell Surface ELISA:
 - Place the plate on ice to stop internalization.
 - Wash the cells three times with ice-cold PBS.
 - Fix the cells with 4% paraformaldehyde for 15 minutes at room temperature.
 - Wash three times with PBS.
 - Block with 3% BSA in PBS for 1 hour.
 - Incubate with the primary anti-PAR1 antibody for 1 hour.

- Wash three times with PBS.
- Incubate with HRP-conjugated secondary antibody for 1 hour.
- Wash three times with PBS.
- Add substrate and measure absorbance.
- For Flow Cytometry:
 - Place the cells on ice.
 - Gently detach the cells (if adherent).
 - Incubate with the primary anti-PAR1 antibody in FACS buffer for 30 minutes on ice.
 - Wash the cells.
 - Incubate with the fluorescently labeled secondary antibody for 30 minutes on ice in the dark.
 - Wash the cells and analyze by flow cytometry.
- For Confocal Microscopy:
 - Wash cells with ice-cold PBS.
 - Fix and permeabilize (if looking at total receptor) or just fix (for surface labeling).
 - Proceed with immunofluorescence staining as described above.
- Data Analysis: Quantify the amount of surface PAR1 remaining after **TRAP-5 amide** stimulation in the presence and absence of the inhibitor. Calculate the percentage of internalization and the percentage of inhibition.

Protocol 2: Cell Surface Biotinylation Assay to Measure PAR1 Internalization

Objective: To quantify the rate of PAR1 internalization by labeling surface proteins with a cleavable biotinylation reagent.

Materials:

- Sulfo-NHS-SS-Biotin (cleavable biotin)
- Quenching solution (e.g., 100 mM glycine in PBS)
- Lysis buffer (e.g., RIPA buffer)
- Streptavidin-agarose beads
- Glutathione solution (for cleaving biotin)
- SDS-PAGE and Western blotting reagents
- Anti-PAR1 antibody

Procedure:

- Cell Culture: Grow PAR1-expressing cells to confluency.
- Biotinylation:
 - Wash cells twice with ice-cold PBS.
 - Incubate cells with Sulfo-NHS-SS-Biotin (0.5 mg/ml in PBS) for 30 minutes at 4°C with gentle agitation.
 - Quench the reaction by washing three times with quenching solution.
- Internalization:
 - Add pre-warmed cell culture medium and incubate at 37°C for desired time points to allow internalization.
- Biotin Removal from Surface Proteins:

- Place cells on ice and wash with ice-cold PBS.
- Treat cells with a membrane-impermeable reducing agent like glutathione to cleave the biotin from proteins remaining on the cell surface.
- Cell Lysis and Pulldown:
 - Lyse the cells in lysis buffer.
 - Incubate the cell lysate with streptavidin-agarose beads to capture the biotinylated (internalized) proteins.
 - Wash the beads extensively.
- Analysis:
 - Elute the captured proteins from the beads.
 - Analyze the eluates by SDS-PAGE and Western blotting using an anti-PAR1 antibody to quantify the amount of internalized receptor.

Mandatory Visualizations

Signaling Pathway of TRAP-5 Amide-Induced PAR1 Internalization

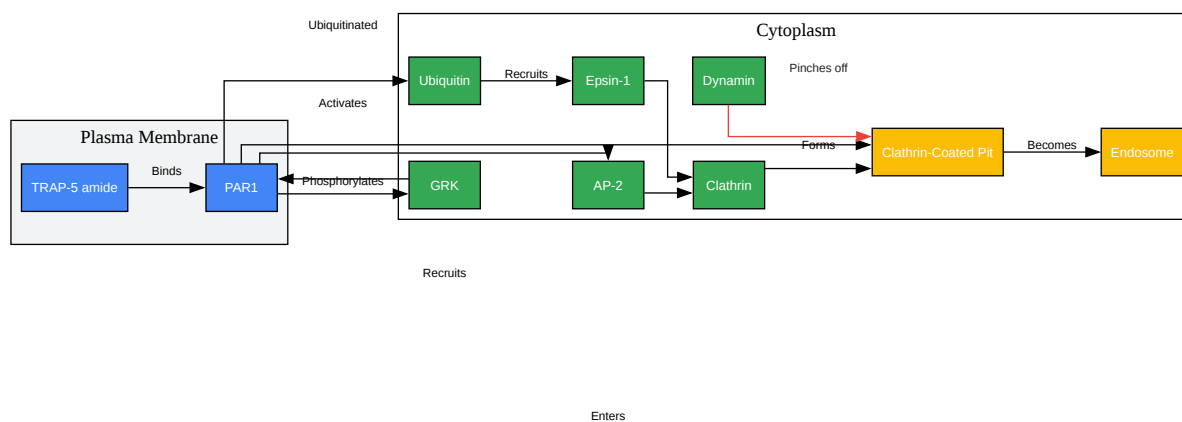

[Click to download full resolution via product page](#)

Caption: **TRAP-5 amide**-induced PAR1 internalization pathway.

Experimental Workflow for Inhibiting PAR1 Internalization

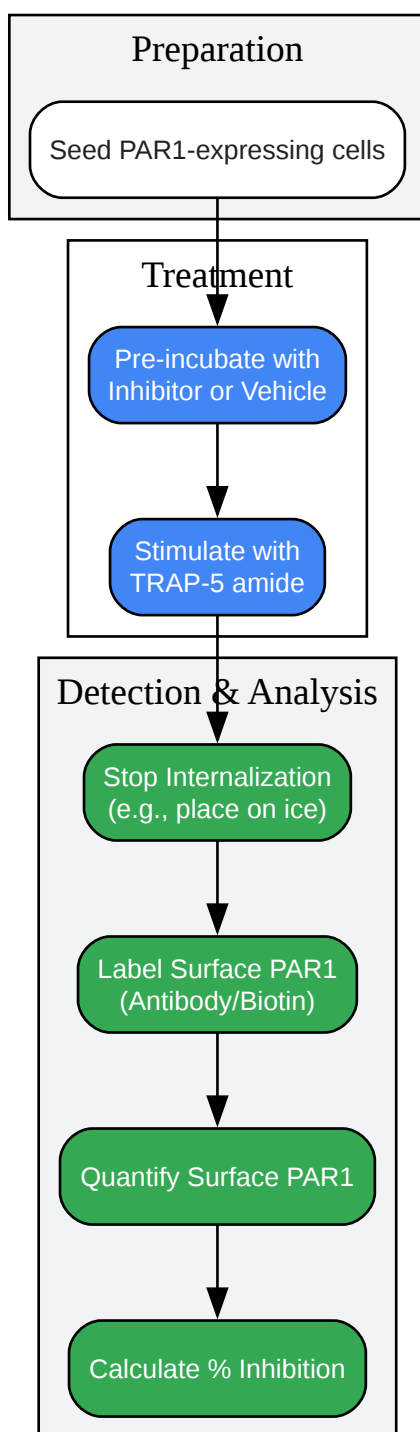

[Click to download full resolution via product page](#)

Caption: Workflow for assessing inhibitors of PAR1 internalization.

Logical Relationship of Key Proteins in PAR1 Endocytosis

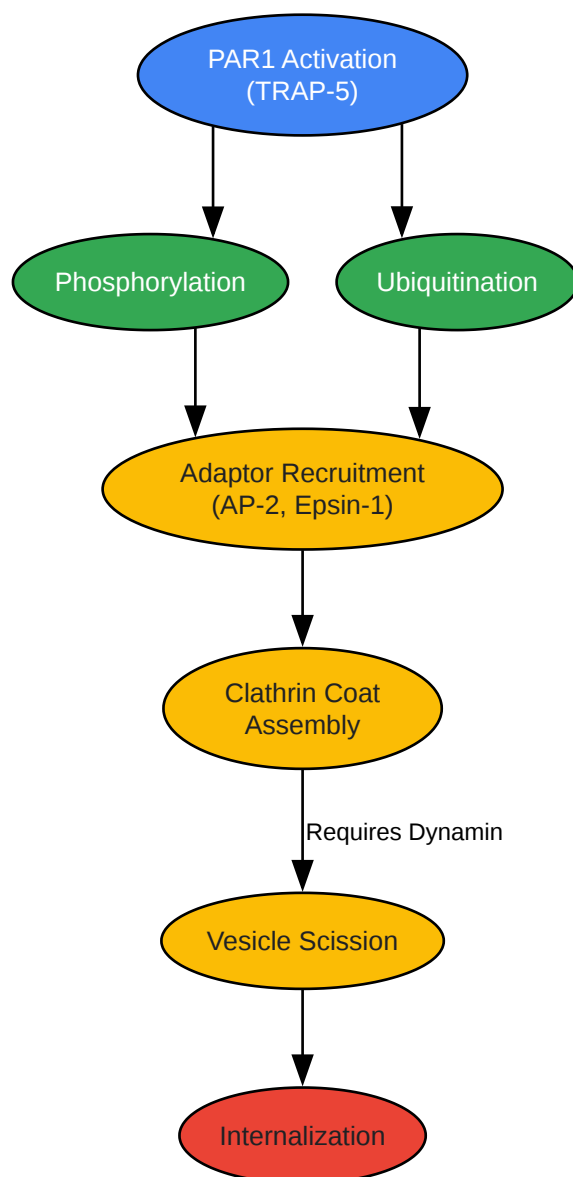

[Click to download full resolution via product page](#)

Caption: Key molecular events in PAR1 endocytosis.

Need Custom Synthesis?

BenchChem offers custom synthesis for rare earth carbides and specific isotopic labeling.

Email: info@benchchem.com or [Request Quote Online](#).

References

- 1. A new inhibitor of the β -arrestin/AP2 endocytic complex reveals interplay between GPCR internalization and signalling - PMC [[pmc.ncbi.nlm.nih.gov](https://pubmed.ncbi.nlm.nih.gov)]
- 2. Building a better dynasore: the dyngo compounds potently inhibit dynamin and endocytosis - PubMed [pubmed.ncbi.nlm.nih.gov]
- 3. Human PAR1 ELISA Kit [ABIN6954856] - Cell Lysate, Tissue Homogenate [antibodies-online.com]
- 4. Whole-cell radioligand binding for receptor internalization: Research protocol with step-by-step guide and materials - Peeref [peeref.com]
- 5. giffordbioscience.com [giffordbioscience.com]
- To cite this document: BenchChem. [Technical Support Center: Mitigating TRAP-5 Amide-Induced Receptor Internalization]. BenchChem, [2026]. [Online PDF]. Available at: [<https://www.benchchem.com/product/b118074/docs#technical-support-center-mitigating-trap-5-amide-induced-receptor-internalization>]

Disclaimer & Data Validity:

The information provided in this document is for Research Use Only (RUO) and is strictly not intended for diagnostic or therapeutic procedures. While BenchChem strives to provide accurate protocols, we make no warranties, express or implied, regarding the fitness of this product for every specific experimental setup.

Technical Support: The protocols provided are for reference purposes. Unsure if this reagent suits your experiment?

Need Industrial/Bulk Grade? [Request Custom Synthesis Quote](#)

BenchChem

Our mission is to be the trusted global source of essential and advanced chemicals, empowering scientists and researchers to drive progress in science and industry.

Contact

Address: 3281 E Guasti Rd

Ontario, CA 91761, United States

Phone: (601) 213-4426

Email: info@benchchem.com

[Contact our Ph.D. Support Team for a compatibility check](#)