

# Application Note: High-Resolution HPLC Analysis of 7-O-(Triethylsilyl) Paclitaxel

**Author:** BenchChem Technical Support Team. **Date:** May 2026

## Compound of Interest

Compound Name: 7-O-(Triethylsilyl) Paclitaxel

CAS No.: 148930-55-6

Cat. No.: B118307

[Get Quote](#)

## Abstract

This application note details a robust, self-validating Reverse-Phase HPLC (RP-HPLC) protocol for the analysis of **7-O-(Triethylsilyl) Paclitaxel** (7-TES-Paclitaxel). As a critical intermediate in the semi-synthesis of Paclitaxel (Taxol®) and a potential process impurity (designated as Impurity K in some pharmacopeial contexts), accurate quantification of 7-TES-Paclitaxel is essential for Process Analytical Technology (PAT) and final product release.

This guide addresses the specific chromatographic challenges posed by the high lipophilicity of the TES protecting group, providing a method that achieves baseline resolution between 7-TES-Paclitaxel, Paclitaxel, and the 10-Deacetylbaccatin III (10-DAB) core.

## Part 1: The Analyte & Chromatographic Challenge

### Chemical Context

7-TES-Paclitaxel is formed by the protection of the C7-hydroxyl group of the taxane core with a triethylsilyl (TES) moiety. This step is often necessary to direct subsequent chemical

modifications to the C13 side chain or other positions without affecting the sensitive C7 position.

- **Molecular Difference:** The addition of the TES group ( ) significantly increases the hydrophobicity of the molecule compared to native Paclitaxel.
- **Stability Warning:** Silyl ethers are susceptible to acid-catalyzed hydrolysis. While TES is more stable than Trimethylsilyl (TMS), the analytical method must avoid extremely low pH (< 2.0) for extended periods to prevent on-column degradation.

## The Separation Logic (The "Why")

Standard isocratic methods for Paclitaxel (often ~50:50 Water:Acetonitrile) are insufficient for 7-TES-Paclitaxel.

- **Problem:** Under isocratic conditions suitable for Paclitaxel, the 7-TES analog retains too strongly, leading to broad, undetectable peaks or carryover into subsequent injections.
- **Solution:** A Gradient Elution profile is mandatory. The method must start with moderate organic content to resolve polar impurities (like Baccatin III) and ramp to high organic content (>80% ACN) to elute the hydrophobic 7-TES species as a sharp peak.

## Part 2: Critical Method Parameters (CMP) Instrumentation & Conditions

| Parameter      | Specification                                      | Rationale   |
|----------------|--|---|
| Column         | C18 (L1), End-capped, 4.6 x 150 mm, 3.5 µm or 5 µm | End-capping reduces silanol interactions with the taxane nitrogen, improving peak symmetry.               |
| Mobile Phase A | Water (Milli-Q)                                    | Pure aqueous phase prevents buffer precipitation in high organic gradients.                               |
| Mobile Phase B | Acetonitrile (HPLC Grade)                          | ACN provides sharper peaks for taxanes compared to Methanol due to lower viscosity and better solubility. |
| Flow Rate      | 1.0 - 1.2 mL/min                                   | Optimized for standard backpressure limits (< 400 bar).   |
| Detection      | UV @ 227 nm  | The taxane ring system has maximum absorbance at 227 nm.  |
| Temperature    | 30°C - 40°C  | Slightly elevated temperature reduces viscosity and improves mass transfer for bulky taxanes.             |
| Injection Vol  | 10 µL  | Standard volume; reduce to 5 µL if peak fronting occurs.  |

## Gradient Profile (The "Engine")

This gradient is designed to separate the "Early Eluters" (10-DAB, Baccatin III), the "Target" (Paclitaxel), and the "Late Eluters" (7-TES-Paclitaxel).

| Time (min) | % Mobile Phase A (Water) | % Mobile Phase B (ACN) | Event   |
|------------|--------------------------|------------------------|---|
| 0.0        | 65                       | 35                     | Equilibration: Load polar impurities.           |
| 15.0       | 35                       | 65                     | Ramp 1: Elute Paclitaxel (~10-12 min).          |
| 25.0       | 5                        | 95                     | Ramp 2: Elute 7-TES-Paclitaxel (~18-22 min).    |
| 30.0       | 5                        | 95                     | Wash: Clear column of lipophilic dimers.        |
| 30.1       | 65                       | 35                     | Reset: Return to initial conditions.            |
| 35.0       | 65                       | 35                     | Re-equilibration: Critical for reproducibility. |

## Part 3: Standard Operating Procedure (SOP)

### Sample Preparation

Caution: Taxanes are cytotoxic. Handle with appropriate PPE in a fume hood.

- Stock Solution (1.0 mg/mL): Weigh 10 mg of 7-TES-Paclitaxel reference standard. Dissolve in 10 mL of Acetonitrile.
  - Note: Do not use Methanol if transesterification is a concern during long-term storage, though ACN is generally preferred for solubility of the TES analog.
- Working Standard (0.1 mg/mL): Dilute 1 mL of Stock Solution into 9 mL of Mobile Phase Initial Blend (65:35 Water:ACN).

- Why this blend? Matching the sample solvent to the initial mobile phase prevents "solvent shock" which causes peak splitting for early eluting compounds.
- Filtration: Filter through a 0.22  $\mu\text{m}$  PTFE syringe filter into an amber HPLC vial (taxanes are light-sensitive).

## System Suitability Testing (SST)

Before running samples, inject the Working Standard 5 times.

- RSD of Peak Area:  $\leq 2.0\%$ [1]
- Tailing Factor (T):  $0.8 < T < 1.5$
- Theoretical Plates (N):  $> 5,000$

## Part 4: Visualization of Workflows

### Analytical Workflow Diagram

This diagram outlines the decision process for analyzing reaction mixtures containing both Paclitaxel and its 7-TES intermediate.

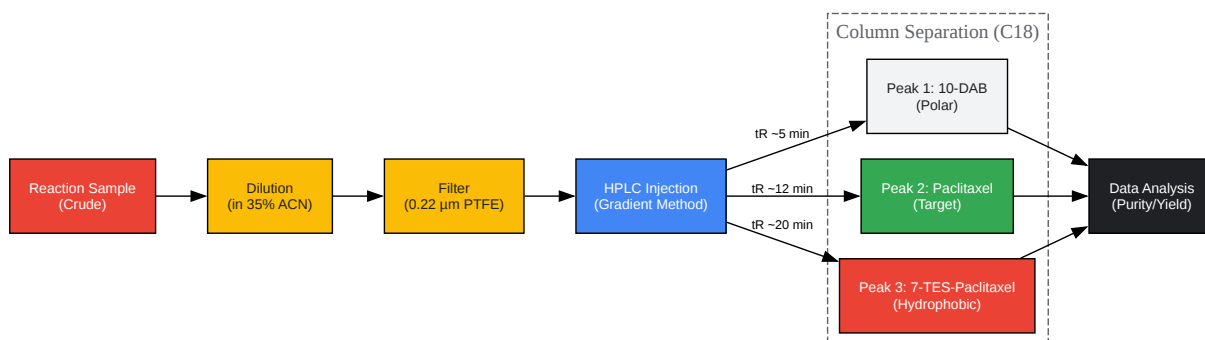

[Click to download full resolution via product page](#)

Caption: Figure 1: Analytical workflow for separating polar precursors and hydrophobic TES-intermediates.

## Synthesis Context Diagram

Understanding where 7-TES fits in the synthesis helps the analyst anticipate impurities.

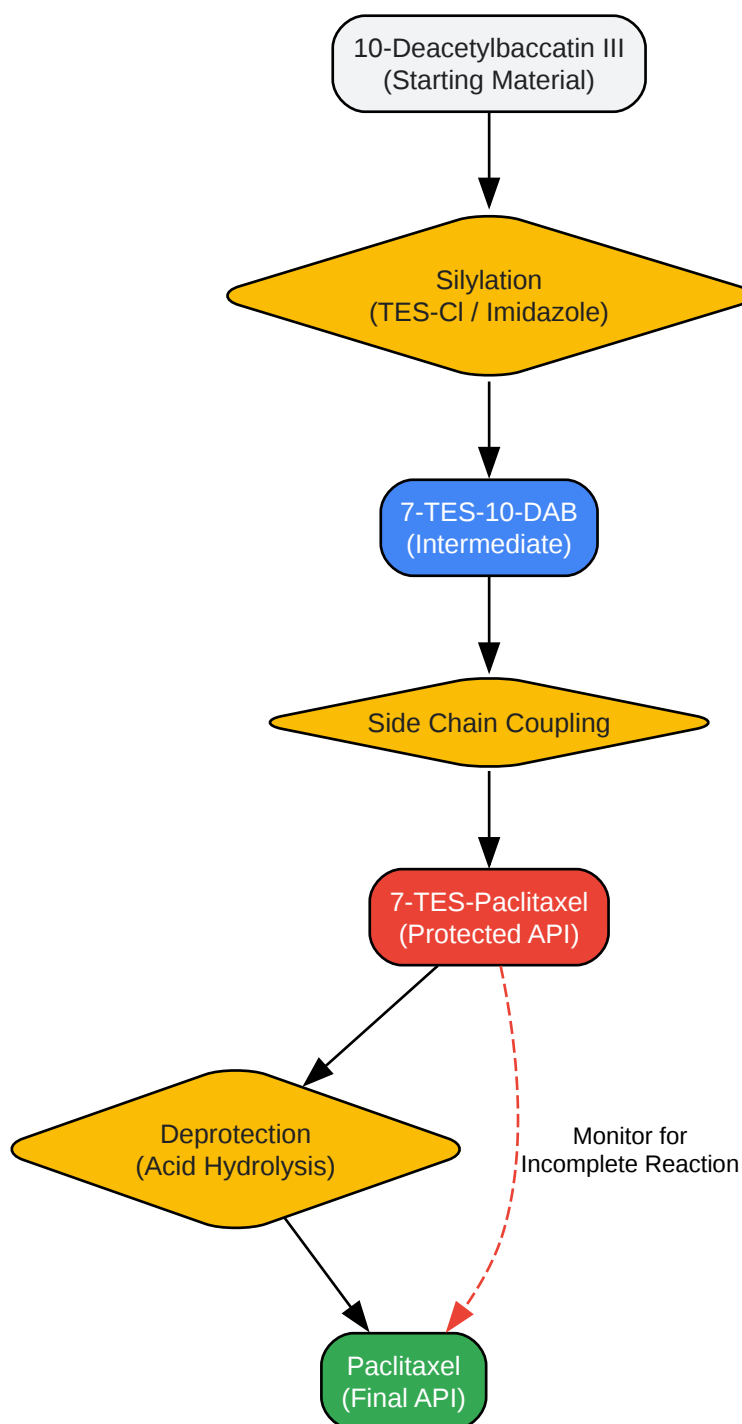

[Click to download full resolution via product page](#)

Caption: Figure 2: Semi-synthesis pathway showing 7-TES-Paclitaxel as the direct precursor to Paclitaxel.

## Part 5: Data Analysis & Troubleshooting

## Relative Retention Times (RRT)

Using Paclitaxel as the reference marker (RRT = 1.00), typical retention behaviors on a C18 column with the gradient described above are:

| Compound                | Approx. <sup>[1][2][3][4][5][6][7]</sup><br><sup>[8][9][10]</sup> RRT | Behavior   |
|-------------------------|---|--|
| 10-Deacetylbaccatin III | 0.20  | Highly Polar; elutes in the void/early gradient.   |
| Baccatin III            | 0.45  | Polar core; elutes before Paclitaxel.              |
| Paclitaxel              | 1.00  | Reference Peak.                                    |
| 7-Epi-Paclitaxel        | 1.40  | Common isomer impurity.                            |
| 7-TES-Paclitaxel        | 1.80 - 2.10   | Analyte of Interest. Strongly retained due to TES. |

## Troubleshooting Guide

- Issue: 7-TES Peak Splitting.
  - Cause: Sample solvent is too strong (100% ACN) compared to the initial mobile phase (35% ACN).
  - Fix: Dilute sample in 50:50 Water:ACN.
- Issue: "Ghost" Peaks in Blank.
  - Cause: Carryover of 7-TES from previous run due to insufficient column wash.
  - Fix: Extend the "Wash" phase (95% ACN) by 5 minutes or inject a blank needle wash.
- Issue: Degradation of 7-TES.
  - Cause: Acidic mobile phase used for too long.

- Fix: Ensure the mobile phase pH is not < 3.0. If using Trifluoroacetic acid (TFA), switch to Formic Acid or Phosphate buffer (pH 4.5).

## References

- National Center for Biotechnology Information (NCBI). PubChem Compound Summary for CID 1491354, Paclitaxel Related Compound B (10-deacetyl-7-epipaclitaxel). Retrieved from [\[Link\]](#)
- Pharmaffiliates. Paclitaxel - Impurity K (7-TES-Paclitaxel) Reference Standard. Retrieved from [\[Link\]](#)<sup>[10]</sup>
- Vertex AI Search. Validated HPLC Method for the Determination of Paclitaxel-related Substances. (Context for separation of lipophilic taxane impurities). Retrieved from [\[Link\]](#)

### Need Custom Synthesis?

BenchChem offers custom synthesis for rare earth carbides and specific isotopic labeling.

Email: [info@benchchem.com](mailto:info@benchchem.com) or [Request Quote Online](#).

## Sources

- [1. drugfuture.com](https://drugfuture.com) [[drugfuture.com](https://drugfuture.com)]
- [2. pharmaffiliates.com](https://pharmaffiliates.com) [[pharmaffiliates.com](https://pharmaffiliates.com)]
- [3. researchgate.net](https://researchgate.net) [[researchgate.net](https://researchgate.net)]
- [4. derpharmachemica.com](https://derpharmachemica.com) [[derpharmachemica.com](https://derpharmachemica.com)]
- [5. brieflands.com](https://brieflands.com) [[brieflands.com](https://brieflands.com)]
- [6. A Rapid and Sensitive HPLC Method for Quantitation of Paclitaxel in Biological Samples using Liquid-Liquid Extraction and UV Detection: Application to Pharmacokinetics and Tissues Distribution Study of Paclitaxel Loaded Targeted Polymeric Micelles in Tumor Bearing Mice - PubMed](#) [[pubmed.ncbi.nlm.nih.gov](https://pubmed.ncbi.nlm.nih.gov)]
- [7. Paclitaxel - Definition, Identification, Assay - USP 2025](https://trungtamthuoc.com) [[trungtamthuoc.com](https://trungtamthuoc.com)]
- [8. Liquid-Liquid Extraction for Recovery of Paclitaxel from Plant Cell Culture: Solvent Evaluation and Use of Extractants for Partitioning and Selectivity - PMC](#) [[pmc.ncbi.nlm.nih.gov](https://pmc.ncbi.nlm.nih.gov)]

- [9. jsaer.com \[jsaer.com\]](#)
- [10. pharmaffiliates.com \[pharmaffiliates.com\]](#)
- To cite this document: BenchChem. [Application Note: High-Resolution HPLC Analysis of 7-O-(Triethylsilyl) Paclitaxel]. BenchChem, [2026]. [Online PDF]. Available at: [<https://www.benchchem.com/product/b118307/docs#application-note-high-resolution-hplc-analysis-of-7-o-triethylsilyl-paclitaxel>]

---

### Disclaimer & Data Validity:

The information provided in this document is for Research Use Only (RUO) and is strictly not intended for diagnostic or therapeutic procedures. While BenchChem strives to provide accurate protocols, we make no warranties, express or implied, regarding the fitness of this product for every specific experimental setup.

**Technical Support:** The protocols provided are for reference purposes. Unsure if this reagent suits your experiment?

**Need Industrial/Bulk Grade?** [Request Custom Synthesis Quote](#)

## BenchChem

Our mission is to be the trusted global source of essential and advanced chemicals, empowering scientists and researchers to drive progress in science and industry.

### Contact

Address: 3281 E Guasti Rd  
Ontario, CA 91761, United States  
Phone: (601) 213-4426  
Email: [info@benchchem.com](mailto:info@benchchem.com)

[Contact our Ph.D. Support Team for a compatibility check](#)