

A Comparative Guide to Diethylamine Phosphate and the Inorganic Ferroelectric KDP

Author: BenchChem Technical Support Team. **Date:** December 2025

Compound of Interest

Compound Name: Diethylamine phosphate

Cat. No.: B118757

[Get Quote](#)

For Researchers, Scientists, and Drug Development Professionals

This guide provides a detailed comparison of the organic ferroelectric candidate, **Diethylamine Phosphate** (DEAP), and the well-established inorganic ferroelectric, Potassium Dihydrogen Phosphate (KDP). While KDP is a thoroughly characterized material with extensive applications in nonlinear optics and electro-optics, DEAP is noted in chemical and materials science literature primarily for its potential use in ferroelectric and piezoelectric research. This comparison aims to consolidate the known properties of both materials, supported by experimental data where available, to inform materials selection and future research directions.

Quantitative Performance Comparison

A significant disparity exists in the publicly available experimental data for DEAP compared to KDP. While KDP has been the subject of extensive research, resulting in well-defined ferroelectric parameters, quantitative data for the ferroelectric properties of DEAP are not readily found in the reviewed literature.

Table 1: Comparison of Ferroelectric Properties

Property	Diethylamine Phosphate (DEAP)	Potassium Dihydrogen Phosphate (KDP)
Curie Temperature (T _c)	Data not available in searched literature. A study using Differential Scanning Calorimetry (DSC) from 183 K to 293 K showed no significant thermal events[1].	~123 K (-150 °C)
Spontaneous Polarization (P _s)	Data not available	~5 μC/cm ² (at 77 K)
Coercive Field (E _c)	Data not available	~2 kV/cm (at 77 K)
Dielectric Constant (ε)	Data not available	Varies significantly with temperature and crystal orientation.

Foundational Differences and Structural Insights

KDP is a classic example of a hydrogen-bonded ferroelectric material. Its ferroelectric properties are intricately linked to the ordering of protons within its crystal structure below the Curie temperature. This proton ordering leads to a distortion of the phosphate tetrahedra and a net spontaneous polarization.

Diethylamine phosphate is an organic salt. While its application in ferroelectric and piezoelectric research is mentioned, the specific mechanisms driving its potential ferroelectric behavior are not detailed in the available literature. A study on its crystal structure revealed a triclinic system, and differential scanning calorimetry showed no phase transitions between 183 K and 293 K[1].

Experimental Methodologies

The characterization of ferroelectric materials involves a suite of well-established experimental techniques to determine their key performance parameters.

Ferroelectric Hysteresis Loop Measurement

The Sawyer-Tower circuit is a fundamental setup used to measure the ferroelectric hysteresis loop (Polarization vs. Electric Field). This measurement provides crucial parameters such as the spontaneous polarization (P_s), remnant polarization (P_r), and coercive field (E_c).

Experimental Workflow: Sawyer-Tower Circuit

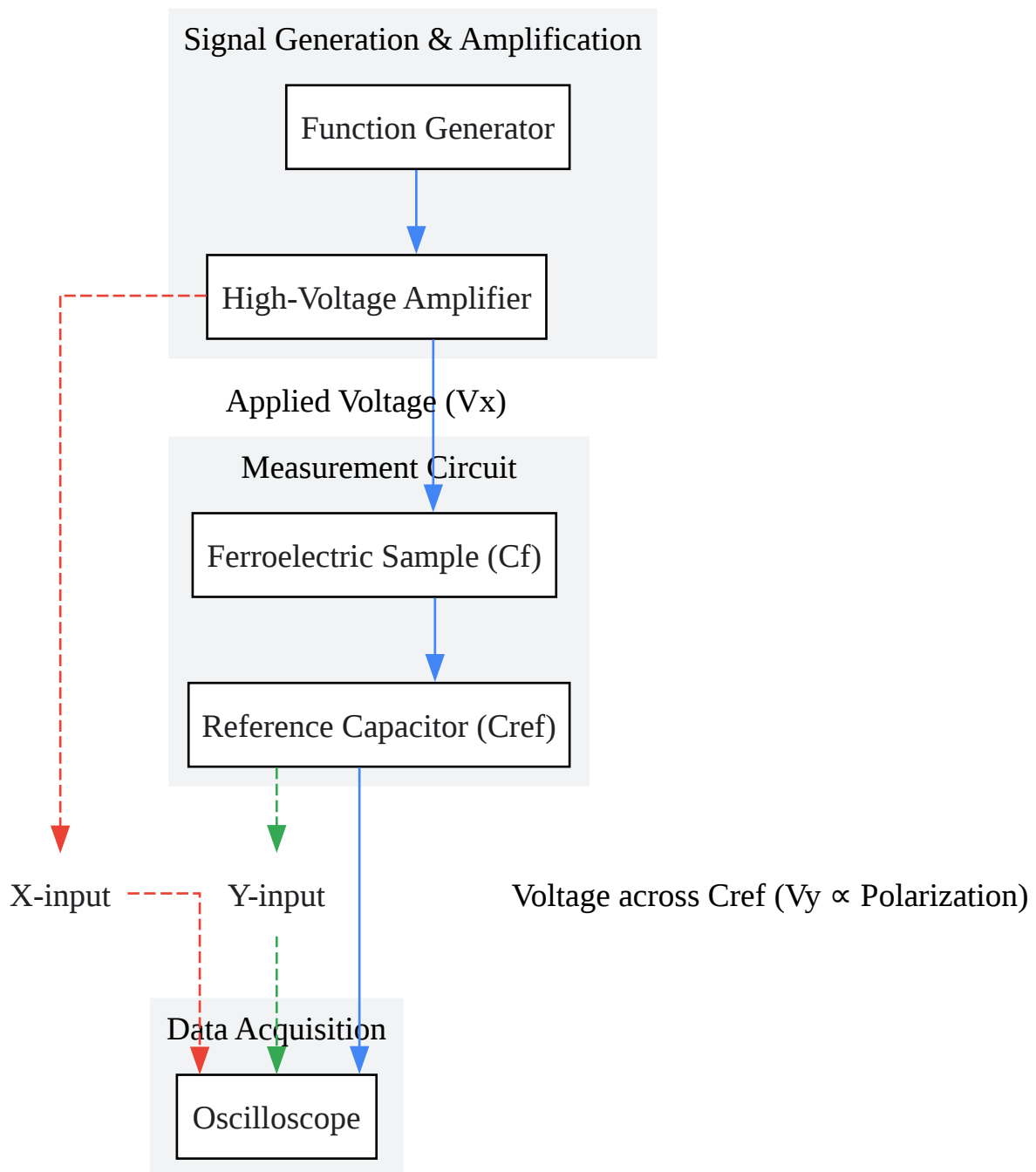

[Click to download full resolution via product page](#)

Caption: Workflow of a Sawyer-Tower circuit for ferroelectric hysteresis measurement.

Protocol:

- A sinusoidal voltage from a function generator is amplified by a high-voltage amplifier.
- The amplified voltage is applied to the ferroelectric sample connected in series with a standard linear capacitor of known capacitance (C_{ref}), which is significantly larger than the sample capacitance.
- The voltage across the sample (proportional to the electric field) is applied to the X-input of an oscilloscope.
- The voltage across the reference capacitor (proportional to the charge, and thus the polarization of the sample) is applied to the Y-input of the oscilloscope.
- The resulting P-E hysteresis loop is displayed on the oscilloscope screen.

Dielectric Constant Measurement

The dielectric constant is determined by measuring the capacitance of the material as a function of temperature and frequency.

Experimental Workflow: Dielectric Constant Measurement

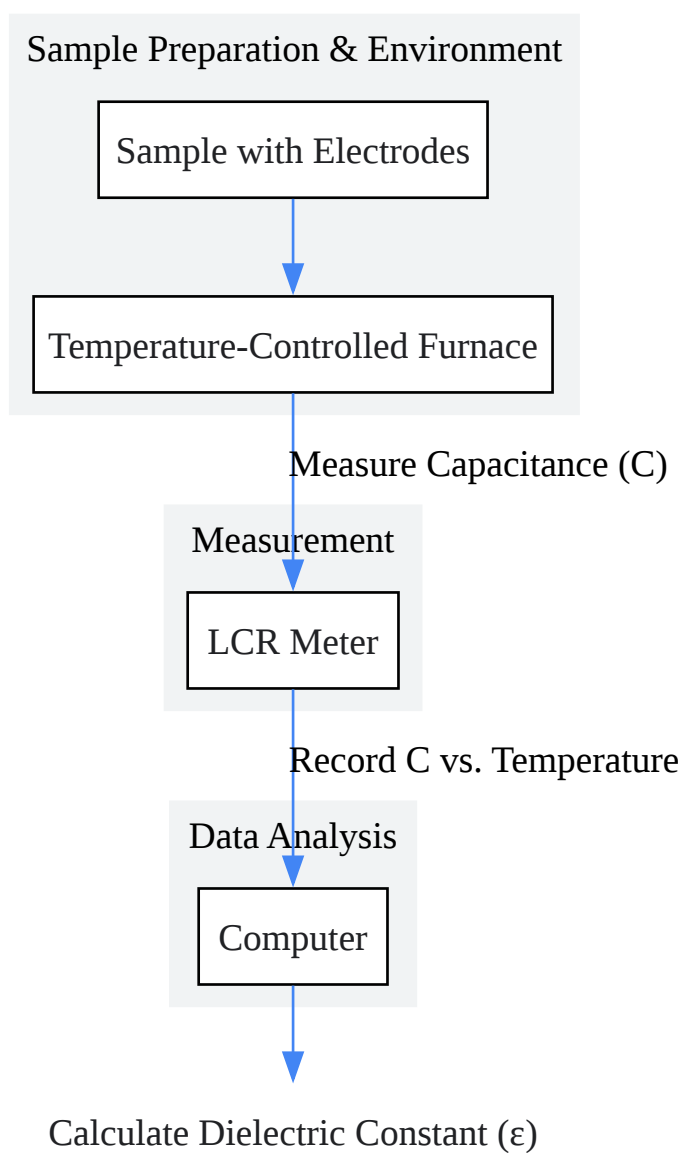

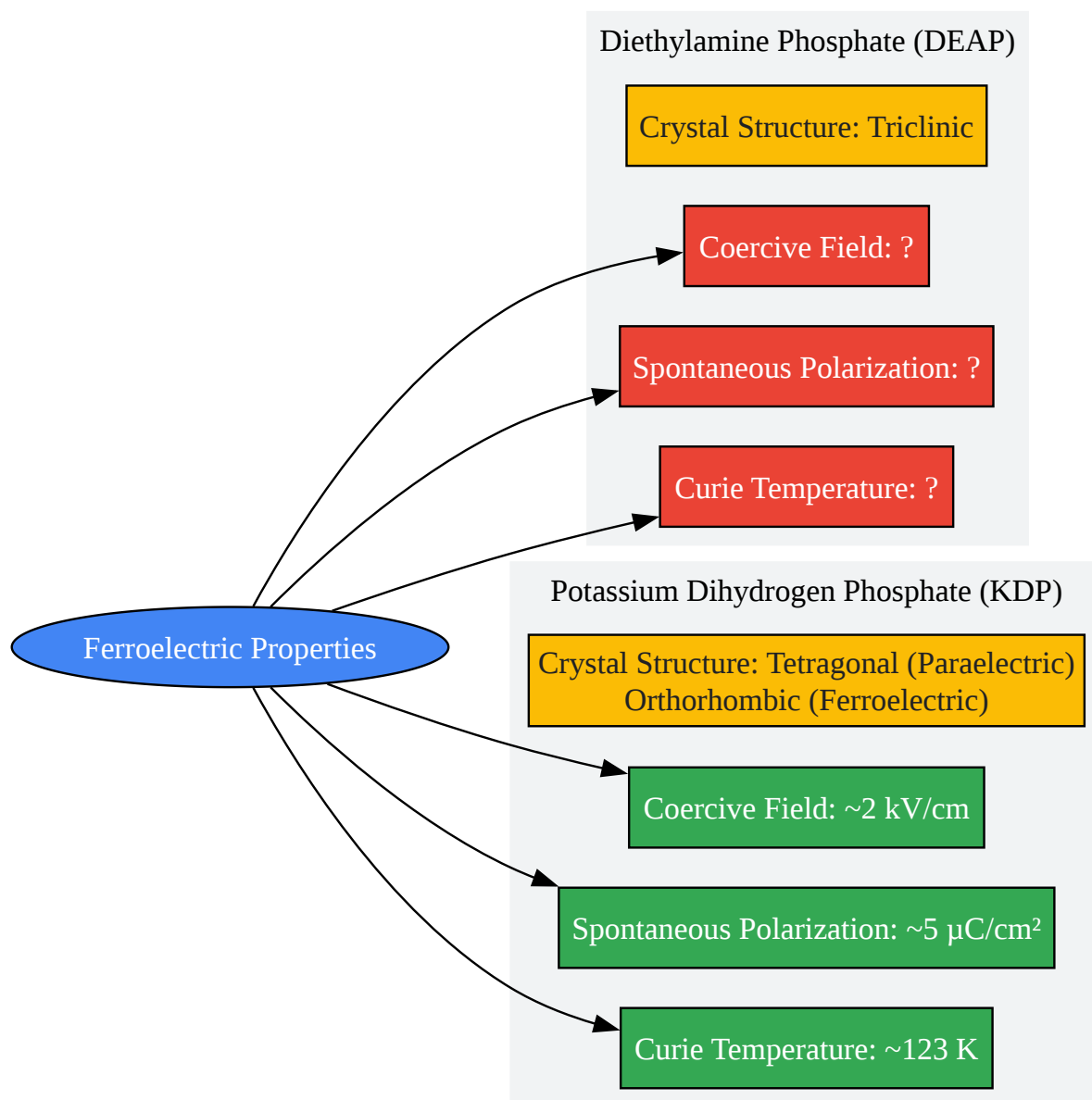

[Click to download full resolution via product page](#)

Need Custom Synthesis?

BenchChem offers custom synthesis for rare earth carbides and specific isotopic labeling.

Email: info@benchchem.com or [Request Quote Online](#).

References

- 1. Diethylammonium dihydrogen orthophosphate - PMC [pmc.ncbi.nlm.nih.gov]
- To cite this document: BenchChem. [A Comparative Guide to Diethylamine Phosphate and the Inorganic Ferroelectric KDP]. BenchChem, [2025]. [Online PDF]. Available at: [https://www.benchchem.com/product/b118757#how-does-diethylamine-phosphate-compare-to-inorganic-ferroelectrics-like-kdp]

Disclaimer & Data Validity:

The information provided in this document is for Research Use Only (RUO) and is strictly not intended for diagnostic or therapeutic procedures. While BenchChem strives to provide accurate protocols, we make no warranties, express or implied, regarding the fitness of this product for every specific experimental setup.

Technical Support: The protocols provided are for reference purposes. Unsure if this reagent suits your experiment? [[Contact our Ph.D. Support Team for a compatibility check](#)]

Need Industrial/Bulk Grade? [Request Custom Synthesis Quote](#)

BenchChem

Our mission is to be the trusted global source of essential and advanced chemicals, empowering scientists and researchers to drive progress in science and industry.

Contact

Address: 3281 E Guasti Rd
Ontario, CA 91761, United States
Phone: (601) 213-4426
Email: info@benchchem.com