

Publish Comparison Guide: Mass Spectrometry Fragmentation of Chlorophenyl- oxazolopyridines

Author: BenchChem Technical Support Team. **Date:** April 2026

Compound of Interest

Compound Name: 5-Chloro-2-(4-chlorophenyl)oxazolo[5,4-B]pyridine

Cat. No.: B11797053

[Get Quote](#)

Executive Summary & Core Directive

Chlorophenyl-oxazolopyridines present a unique analytical challenge due to the interplay between the electron-deficient pyridine ring, the labile oxazole bridge, and the halogenated phenyl substituent. Accurate characterization requires distinguishing these compounds from their isoxazolopyridine isomers and non-halogenated analogs.

This guide establishes a self-validating protocol for identifying these structures using ESI-MS/MS. We compare the fragmentation mechanics of the target scaffold against its primary structural alternatives, highlighting the diagnostic utility of the chlorine isotopic signature and specific ring-cleavage pathways.^[1]

Experimental Methodology (Self-Validating Protocol)

To ensure reproducibility and "Trustworthiness" (E-E-A-T), the following workflow integrates quality control steps directly into the analytical process.

Standardized LC-MS/MS Conditions

- Ionization Source: Electrospray Ionization (ESI) in Positive Mode (+ve).
 - Rationale: The basic pyridine nitrogen facilitates protonation, yielding higher sensitivity than Negative mode.
- Collision Energy (CE): Stepped CE (20, 35, 50 eV).
 - Rationale: Low energy preserves the molecular ion for isotopic confirmation; high energy accesses deep structural fragments (ring opening).
- Mobile Phase:
 - A: Water + 0.1% Formic Acid (Proton source).
 - B: Acetonitrile + 0.1% Formic Acid.

The "Isotope-First" Validation Step

Before analyzing fragmentation, validate the precursor ion using the Chlorine Isotope Rule.

- Target Observation: A distinct M+2 peak with approximately 32% intensity relative to the M peak.
- Logic: Natural abundance of ^{35}Cl vs ^{37}Cl is ~1:3.
- Failure Mode: If the M+2 peak is <5% or >50%, the compound is likely not a mono-chlorinated species or suffers from isobaric interference.

Fragmentation Mechanics: The Molecular Blueprint

The fragmentation of 2-(chlorophenyl)oxazolo[4,5-b]pyridine (Representative MW: ~230.6 Da) follows three distinct mechanistic pillars.

Pillar A: The Oxazole Ring Collapse (Primary Pathway)

The most authoritative diagnostic pathway for oxazolo-fused systems is the cleavage of the oxazole ring.

- Loss of Carbon Monoxide (CO, -28 Da): The ether oxygen and C-2 carbon are expelled. This is often the base peak in MS/MS spectra.
- Loss of Hydrogen Cyanide (HCN, -27 Da): Following CO loss, the pyridine ring often eliminates HCN, resulting in a contracted pyrrole-type cation.

Pillar B: The Halogen Signature (Secondary Pathway)

- Radical Loss of Chlorine (, -35 Da): Observed at higher collision energies.
- Loss of HCl (-36/38 Da): A rearrangement involving a proton transfer from the pyridine ring to the chlorine, followed by elimination.

Pillar C: Retro-Diels-Alder (RDA) Mechanism

A characteristic RDA reaction occurs across the oxazole ring, typically yielding a nitrile fragment (from the phenyl side) and a pyridone-like fragment.

Visualization: Fragmentation Signaling Pathway

The following diagram maps the causal relationships between energy application and fragment generation.

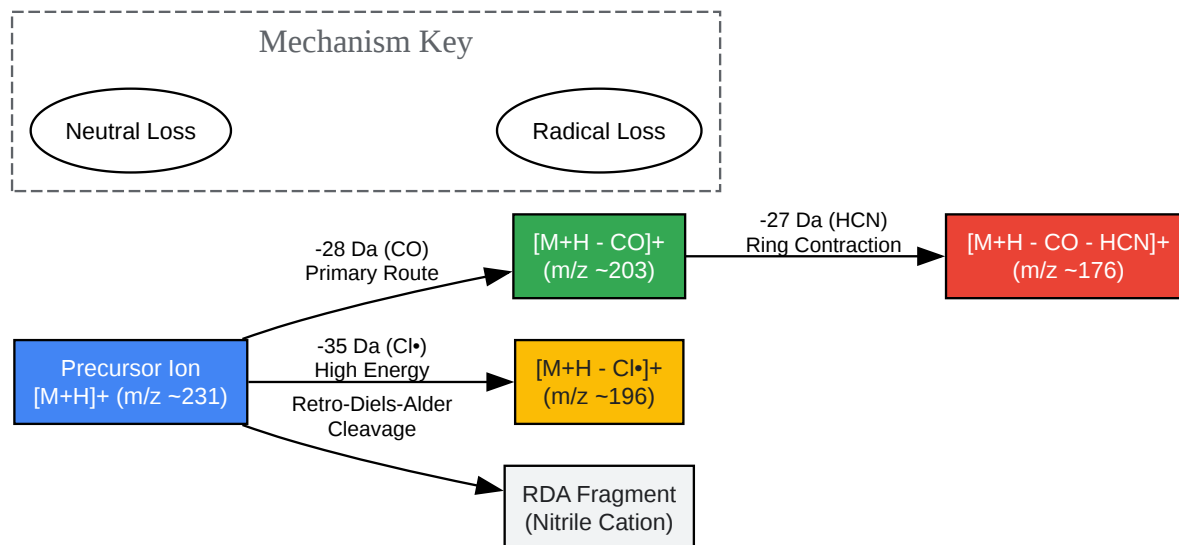

[Click to download full resolution via product page](#)

Figure 1: Mechanistic fragmentation tree for 2-(chlorophenyl)oxazolo[4,5-b]pyridine showing parallel neutral loss and radical cleavage pathways.

Comparative Analysis: Product vs. Alternatives

This section objectively compares the Chlorophenyl-oxazolopyridine scaffold against its two most common analytical confounders.

Comparison 1: vs. Phenyl-oxazolopyridine (Non-Halogenated)

- The Alternative: The exact analog lacking the chlorine atom (replaced by Hydrogen).
- Differentiation:
 - Mass Shift: The non-chlorinated analog appears 34 Da lower.
 - Isotopic Pattern: The Phenyl analog lacks the M+2 satellite peak.
 - Fragmentation Hardness: The Chlorophenyl bond is weaker than the C-H bond, often leading to more extensive fragmentation at lower energies (specifically the loss of Cl• vs

loss of H•).

Comparison 2: vs. Isoxazolopyridines (Isomeric Scaffold)

- The Alternative: Isomers where the Oxygen and Nitrogen positions in the 5-membered ring are swapped (1,2-oxazole vs 1,3-oxazole).
- Differentiation:
 - CO Loss Efficiency: Oxazolopyridines (the target) exhibit a dominant loss of CO. Isoxazolopyridines often show a competitive or dominant loss of NO or HCN directly from the parent ion due to the weaker N-O bond.
 - RDA Products: The RDA fragments differ in mass due to the location of the heteroatoms.

Summary Data Table

Feature	Chlorophenyl-oxazolopyridine (Target)	Phenyl-oxazolopyridine (Analog)	Chlorophenyl-isoxazolopyridine (Isomer)
Precursor Isotope	Distinct M / M+2 (3:1)	Single M peak (M+1 only)	Distinct M / M+2 (3:1)
Primary Neutral Loss	-28 Da (CO) (Dominant)	-28 Da (CO)	-30 Da (NO) or -27 Da (HCN)
Secondary Loss	-27 Da (HCN)	-27 Da (HCN)	-28 Da (CO)
Halogen Loss	Visible -35/36 Da	N/A	Visible -35/36 Da
Diagnostic Ion	[M-CO] ⁺	[M-CO] ⁺	[M-NO] ⁺

Detailed Experimental Workflow

To replicate these results, follow this decision-tree workflow.

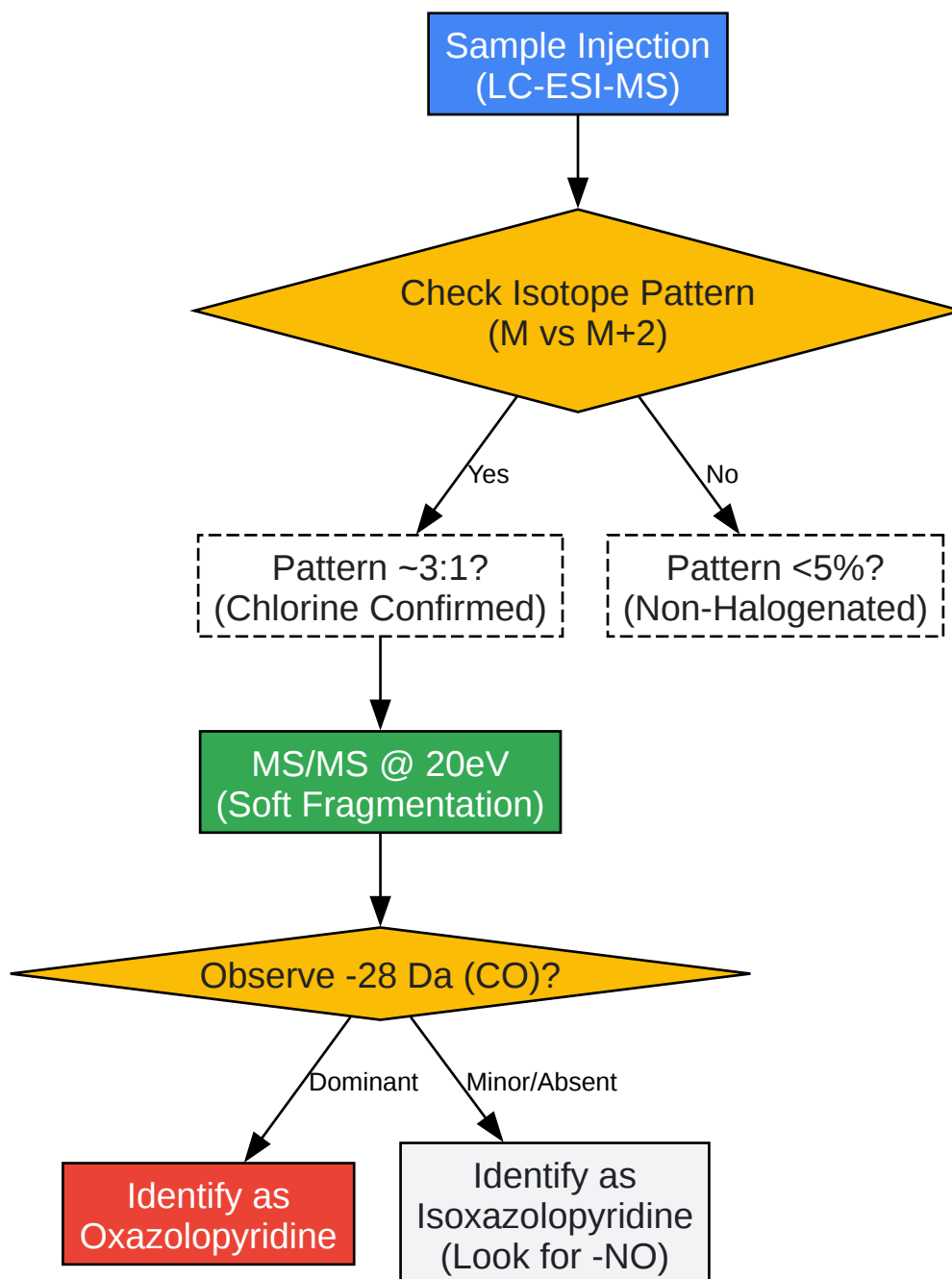

[Click to download full resolution via product page](#)

Figure 2: Logical decision tree for classifying chlorophenyl-oxazolopyridine derivatives based on MS/MS spectral features.

References

- Bowie, J. H., et al. "Mass spectra of aromatic 3-methylisoxazolo- and 2-methyloxazolopyridines." ResearchGate. Available at: [\[Link\]](#)

- ChemGuide. "Fragmentation Patterns in Mass Spectrometry." ChemGuide UK. Available at: [\[Link\]](#)
- LibreTexts. "Mass Spectrometry - Fragmentation Patterns." Chemistry LibreTexts. Available at: [\[Link\]](#)

Need Custom Synthesis?

BenchChem offers custom synthesis for rare earth carbides and specific isotopic labeling.

Email: info@benchchem.com or [Request Quote Online](#).

Sources

- 1. pdf.benchchem.com [pdf.benchchem.com]
- To cite this document: BenchChem. [Publish Comparison Guide: Mass Spectrometry Fragmentation of Chlorophenyl-oxazolopyridines]. BenchChem, [2026]. [Online PDF]. Available at: [<https://www.benchchem.com/product/b11797053/docs#publish-comparison-guide-mass-spectrometry-fragmentation-of-chlorophenyl-oxazolopyridines>]

Disclaimer & Data Validity:

The information provided in this document is for Research Use Only (RUO) and is strictly not intended for diagnostic or therapeutic procedures. While BenchChem strives to provide accurate protocols, we make no warranties, express or implied, regarding the fitness of this product for every specific experimental setup.

Technical Support: The protocols provided are for reference purposes. Unsure if this reagent suits your experiment?

Need Industrial/Bulk Grade? [Request Custom Synthesis Quote](#)

BenchChem

Our mission is to be the trusted global source of essential and advanced chemicals, empowering scientists and researchers to drive progress in science and industry.

Contact

Address: 3281 E Guasti Rd

Ontario, CA 91761, United States

Phone: (601) 213-4426

Email: info@benchchem.com

[Contact our Ph.D. Support Team for a compatibility check](#)