

Scalable preparation methods for fluorinated pyrazole amines

Author: BenchChem Technical Support Team. **Date:** April 2026

Compound of Interest

Compound Name: *N*-Ethyl-3-fluoro-1-(1*H*-pyrazol-3-yl)propan-1-amine

Cat. No.: B11793502

[Get Quote](#)

Application Note: Scalable Preparation of Fluorinated Pyrazole Amines

Part 1: Strategic Overview & Synthetic Logic

Fluorinated pyrazole amines are "privileged structures" in modern drug discovery, serving as critical pharmacophores in kinase inhibitors (e.g., Avapritinib, Encorafenib) and agrochemicals. Their value lies in the fluorine atom's ability to modulate pKa, metabolic stability, and lipophilicity. However, scaling these scaffolds presents two distinct challenges: regiocontrol of the hydrazine cyclization and the process safety of handling high-energy nitrogen-rich intermediates.

This guide details three validated protocols for the two most common subclasses:

- 3-Amino-5-(trifluoromethyl)pyrazoles (via condensation of trifluoro-
-ketonitriles).
- 3-Amino-4-fluoropyrazoles (via cyclization of

-fluoro-

-ketonitriles).

- Continuous Flow Processing (for mitigating hydrazine hazards).

Decision Matrix: Selecting the Synthetic Route

The choice of route depends heavily on the position of the fluorine atom and the substitution pattern on the pyrazole nitrogen.

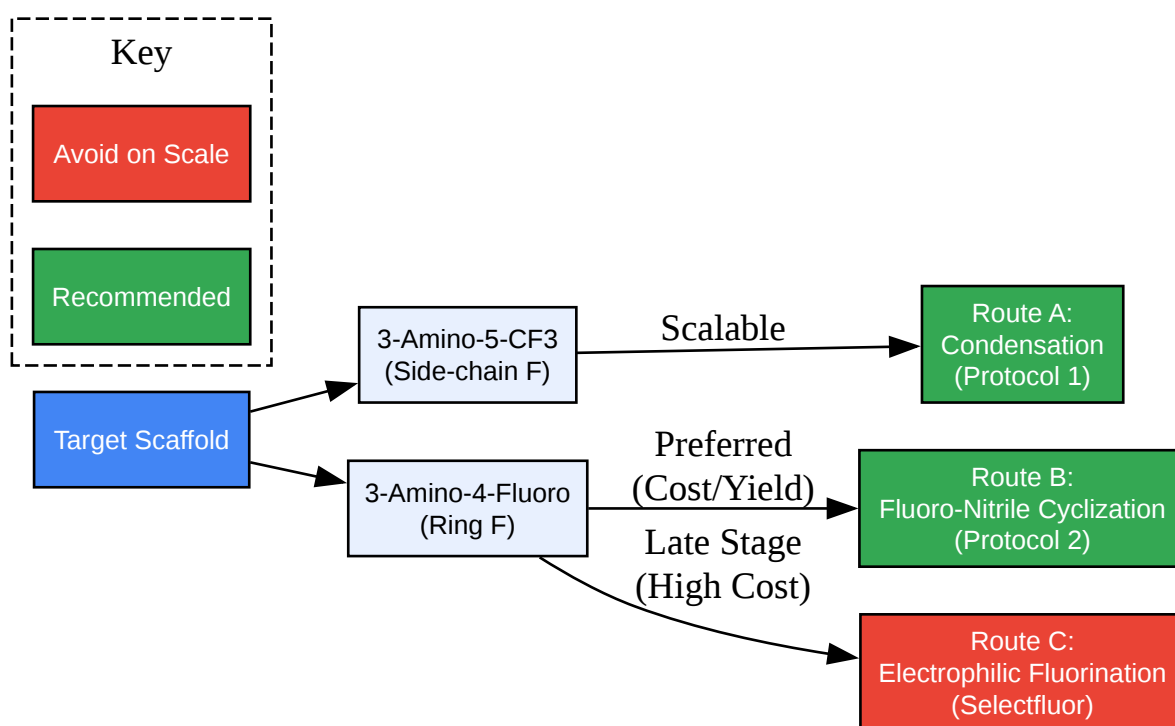

[Click to download full resolution via product page](#)

Figure 1: Strategic decision tree for selecting the optimal synthetic pathway based on the target fluorination pattern.

Part 2: Detailed Experimental Protocols

Protocol 1: Scalable Synthesis of 3-Amino-5-(trifluoromethyl)pyrazole

Target: Gram to Kilogram Scale Preparation

This protocol utilizes 4,4,4-trifluoro-3-oxobutanenitrile as the key building block. The reaction with hydrazine is highly exothermic; strict thermal control is required to prevent "runaway" conditions and to minimize the formation of the 5-hydroxy impurity.

Mechanism & Regioselectivity: When using unsubstituted hydrazine, the product exists as a tautomeric pair (3-amino-5-CF₃ vs. 5-amino-3-CF₃). If a substituted hydrazine (e.g., phenylhydrazine) is used, regioselectivity is governed by the nucleophilicity of the hydrazine nitrogens. The terminal nitrogen (more nucleophilic) typically attacks the ketone carbonyl first, leading to the 5-amino-1-aryl-3-trifluoromethyl isomer.

Materials:

- 4,4,4-Trifluoro-3-oxobutanenitrile (1.0 equiv)
- Hydrazine monohydrate (64% or 80% solution) (1.1 equiv)
- Ethanol (Absolute) (5-7 Volumes)
- Acetic Acid (Catalytic, 0.1 equiv) - Optional, improves rate

Step-by-Step Methodology:

- **Reactor Setup:** Equip a jacketed glass reactor with an overhead mechanical stirrer, internal temperature probe, and a reflux condenser. Purge with nitrogen.
- **Solvation:** Charge Ethanol and 4,4,4-trifluoro-3-oxobutanenitrile. Cool the mixture to 0–5 °C.
- **Controlled Addition (Critical):** Add Hydrazine monohydrate dropwise via a dosing pump.
 - **Rate Limit:** Maintain internal temperature < 10 °C.
 - **Note:** A significant exotherm will occur. Accumulation of unreacted hydrazine at low temp can lead to a sudden thermal spike; ensure good mixing.
- **Reaction:** Once addition is complete, warm the mixture to Room Temperature (20–25 °C) and stir for 1 hour. Then, heat to Reflux (78 °C) for 4–6 hours.
 - **IPC (In-Process Control):** Monitor by HPLC/LC-MS for consumption of nitrile.

- Workup (Crystallization):
 - Distill off ~70% of the Ethanol under reduced pressure.
 - Add Water (3 Volumes) slowly to the warm concentrate.
 - Cool gradually to 0 °C over 2 hours. The product will crystallize as a white to off-white solid.
- Isolation: Filter the solid. Wash with cold water/ethanol (9:1 mixture). Dry in a vacuum oven at 45 °C.

Expected Yield: 85–92% Purity: >98% (HPLC)

Protocol 2: Direct Synthesis of 3-Amino-4-fluoropyrazoles

Target: Accessing the "Ring-Fluorinated" Scaffold

Direct fluorination of the pyrazole ring (using Selectfluor or

gas) is expensive and often yields mixtures. A superior scalable approach involves the cyclization of

-fluoro-

-ketonitriles (e.g., benzoylfluoroacetonitrile).

Materials:

- Benzoylfluoroacetonitrile (1.0 equiv)
- Hydrazine monohydrate (1.2 equiv)
- Ethanol (10 Volumes)
- HCl (conc.) (for pH adjustment if necessary)

Step-by-Step Methodology:

- Dissolution: Dissolve benzoylfluoroacetonitrile in Ethanol in a round-bottom flask.
- Addition: Add Hydrazine monohydrate slowly at room temperature.
- Cyclization: Heat the mixture to Reflux for 8–12 hours.
 - Mechanistic Note: The hydrazine attacks the ketone, forming a hydrazone, which then undergoes intramolecular nucleophilic attack on the nitrile carbon. The fluorine atom at the alpha position is stable under these conditions.
- Workup:
 - Concentrate the reaction mixture in vacuo.
 - The residue is often an oil. Triturate with Diisopropyl ether (DIPE) or Heptane/EtOAc to induce crystallization.
- Purification: If necessary, recrystallize from Ethanol/Water.

Expected Yield: 70–80% Key Impurity: 3-phenyl-4-fluoropyrazole (from loss of the amino group, rare but possible if overheating occurs).

Part 3: Process Intensification (Continuous Flow)

For multi-kilogram campaigns, handling large volumes of hydrazine hydrate in batch mode poses a safety risk (toxicity + instability). A continuous flow approach allows for minimal active inventory.

Flow Reactor Setup:

- Pump A: Solution of
-ketonitrile in EtOH.
- Pump B: Solution of Hydrazine hydrate in EtOH.
- Reactor: PFA coil reactor (Residence time: 10–20 mins) submerged in a heating bath.

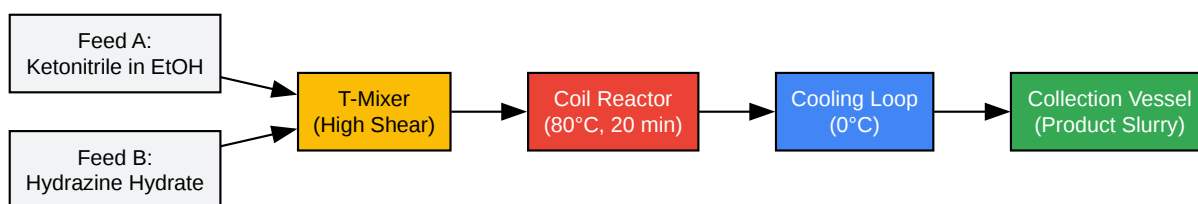

[Click to download full resolution via product page](#)

Figure 2: Process flow diagram for the continuous synthesis of aminopyrazoles, minimizing hydrazine accumulation.

Protocol:

- Concentration: 0.5 M for both streams.
- Flow Rate: Adjusted to achieve 20 min residence time at 80 °C.
- Back Pressure: 5 bar (to prevent solvent boiling).
- Quench: The output stream flows directly into a cooled vessel containing water to trigger immediate precipitation.

Part 4: Critical Process Parameters (CPPs) & Troubleshooting

Parameter	Issue	Mitigation Strategy
Temperature (Addition)	Exotherm > 10°C leads to decomposition.	Use active cooling; dose hydrazine based on thermal response (calorimetry).
Regioselectivity	Formation of wrong isomer (1-aryl systems).	Use Trifluoroethanol (TFE) as solvent (H-bond donor solvent enhances regiocontrol).
Stirring	Thixotropic slurry formation during crystallization.	Ensure high-torque agitation; use a "seed" strategy for crystallization.
Safety	Hydrazine toxicity.[1]	Use a closed system or flow chemistry. Neutralize waste streams with bleach (hypochlorite).

References

- Synthesis of 3-amino-4-fluoropyrazoles. *Journal of Organic Chemistry*, 2011, 76(10), 4105-4111. [Link](#)
- New Synthesis of Fluorinated Pyrazoles. *Organic Letters*, 2010, 12(20), 4648–4651. [Link](#)
- Upscaling and Risk Evaluation of the Synthesis of the 3,5-Diamino-1H-Pyrazole. *Molecules*, 2024, 29(12), 2936. [Link](#)
- Regioselective Synthesis of 5-Trifluoromethylpyrazoles. *Journal of Organic Chemistry*, 2021, 86(3), 2810-2819. [Link](#)
- Fluorinated Pyrazoles: From Synthesis to Applications. *Chemical Reviews*, 2021, 121(3), 1670–1715.[2] [Link](#)

Need Custom Synthesis?

BenchChem offers custom synthesis for rare earth carbides and specific isotopic labeling.

Email: info@benchchem.com or [Request Quote Online](#).

Sources

- [1. researchgate.net \[researchgate.net\]](#)
- [2. Accessing trifluoromethylated SuFEx-able pyrazole via distortion-accelerated 1,3-dipolar cycloadditions - PMC \[pmc.ncbi.nlm.nih.gov\]](#)
- To cite this document: BenchChem. [Scalable preparation methods for fluorinated pyrazole amines]. BenchChem, [2026]. [Online PDF]. Available at: [\[https://www.benchchem.com/product/b11793502/docs#scalable-preparation-methods-for-fluorinated-pyrazole-amines\]](https://www.benchchem.com/product/b11793502/docs#scalable-preparation-methods-for-fluorinated-pyrazole-amines)

Disclaimer & Data Validity:

The information provided in this document is for Research Use Only (RUO) and is strictly not intended for diagnostic or therapeutic procedures. While BenchChem strives to provide accurate protocols, we make no warranties, express or implied, regarding the fitness of this product for every specific experimental setup.

Technical Support: The protocols provided are for reference purposes. Unsure if this reagent suits your experiment?

Need Industrial/Bulk Grade? [Request Custom Synthesis Quote](#)

BenchChem

Our mission is to be the trusted global source of essential and advanced chemicals, empowering scientists and researchers to drive progress in science and industry.

Contact

Address: 3281 E Guasti Rd

Ontario, CA 91761, United States

Phone: (601) 213-4426

Email: info@benchchem.com

Contact our Ph.D. Support Team for a compatibility check