

Application Note: Scalable Synthesis of Methylthio-Substituted Furan Esters

Author: BenchChem Technical Support Team. **Date:** April 2026

Compound of Interest

Compound Name: *Methyl 4-bromo-5-(methylthio)furan-2-carboxylate*

Cat. No.: *B11793463*

[Get Quote](#)

Executive Summary

Methylthio-substituted furan esters are critical pharmacophores in drug discovery (e.g., H₂-receptor antagonists) and high-value intermediates in the flavor/fragrance industry. While laboratory-scale synthesis (mg to g) is routine, scaling to kilogram quantities presents two distinct challenges: regiocontrol of the furan ring functionalization and containment of highly potent organosulfur odors.

This Application Note details a robust, scalable protocol for synthesizing Methyl 5-(methylthio)furan-2-carboxylate via regioselective lithiation. Unlike traditional batch methods that suffer from "hot spots" and side reactions, this guide advocates for a Continuous Flow approach for the metalation step, ensuring safety and yield consistency.

Strategic Route Selection

The Challenge of Furan Functionalization

The furan ring is electron-rich but acid-sensitive. Direct electrophilic sulfenylation is often low-yielding due to polymerization. The most reliable method for introducing a sulfur moiety at the

5-position of a 2-substituted furan is Lithiation-Sulfonylation.

Parameter	Route A: Direct Lithiation (Batch)	Route B: Continuous Flow Lithiation	Route C: Cyclization (Paal-Knorr)
Regioselectivity	High (C5 position)	Very High (Kinetic control)	Moderate (Depends on precursor)
Thermal Control	Difficult (Exotherm risk)	Excellent (High surface-area-to-volume)	Good (Reflux conditions)
Safety (Odor)	High Risk (Open transfers)	Low Risk (Closed system)	Moderate
Scalability	Poor (Cryo limitations)	Excellent (Linear scaling)	Good

Recommendation: Route B (Continuous Flow) is the superior choice for scale-up, minimizing the residence time of unstable lithiated intermediates and eliminating the need for massive cryogenic batch reactors.

Safety & Engineering Controls (Critical)

WARNING: Dimethyl disulfide (DMDS) and the product have extremely low odor thresholds (ppb range). A standard fume hood is insufficient for scale-up.

Odor Abatement System

You must implement a multi-stage scrubber system before starting any reaction.

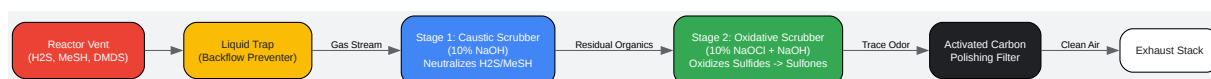

[Click to download full resolution via product page](#)

Figure 1: Multi-stage scrubbing architecture required for organosulfur scale-up. The oxidative stage (Hypochlorite) is non-negotiable for destroying the disulfide motif.

Detailed Protocol: Continuous Flow Synthesis

Reaction Scheme:

- Substrate: Methyl furan-2-carboxylate (dissolved in THF).
- Base: LDA (Lithium Diisopropylamide) or LiTMP (to prevent nucleophilic attack on the ester). Note: n-BuLi is too nucleophilic for furan esters in batch, but can be used in flow with precise residence time control. For robustness, we use LDA.
- Electrophile: Dimethyl Disulfide (DMDS).[1][2]

Equipment Setup[3][4][5][6][7][8]

- Pumps: 3x High-pressure syringe pumps or HPLC pumps (Hastelloy or Stainless Steel; PTFE seals).
- Reactor: Silicon carbide (SiC) or PFA tubing flow reactor.
- Cooling: Cryostat capable of -40°C (Flow allows warmer temps than the -78°C required for batch).

Reagent Preparation

- Stream A (Substrate): 1.0 M Methyl furan-2-carboxylate in anhydrous THF.
- Stream B (Base): 1.1 M LDA in THF/Heptane/Ethylbenzene.
- Stream C (Quench): Neat Dimethyl Disulfide (DMDS).

Experimental Procedure

- System Drying: Flush the entire flow path with anhydrous THF under Argon back-pressure (5 bar) to remove moisture.
- Lithiation Zone (Reactor 1):

- Mix Stream A and Stream B in a T-mixer.
- Residence Time (): 30 seconds.
- Temperature: -20°C.
- Mechanism:[3][4] The kinetic acidity of the C5-proton allows rapid deprotonation. The short residence time prevents the degradation of the ester moiety or ring opening.
- Sulfenylation Zone (Reactor 2):
 - Introduce Stream C (DMDS) into the lithiated stream.
 - Residence Time (): 60 seconds.
 - Temperature: 0°C to Room Temperature (Exotherm is managed by the flow heat exchange).
- Collection & Quench:
 - Direct the output into a stirred vessel containing saturated NH₄Cl solution (cooled to 0°C).
 - Crucial: The collection vessel must be vented to the Scrubber System (Fig 1).

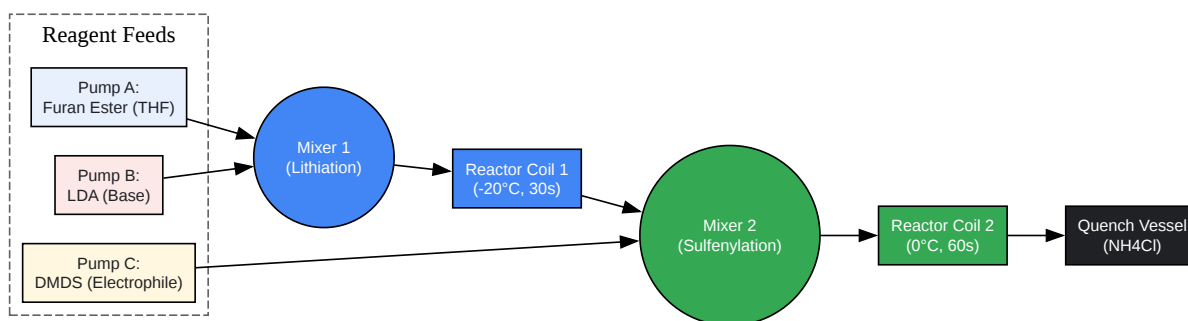

[Click to download full resolution via product page](#)

Figure 2: Continuous flow manifold for the regioselective lithiation-sulfenylation. This setup avoids the cryogenic requirements of batch processing.

Purification & Quality Control

Scaling up purification is often the bottleneck. Distillation of sulfur compounds can lead to degradation and intense odor release.

Work-up Protocol[3]

- Phase Separation: Separate the organic layer from the NH_4Cl quench.
- Wash: Wash organic layer with 1M HCl (to remove diisopropylamine), then NaHCO_3 , then Brine.
- Odor Kill: Wash the organic layer with a dilute (1%) bleach solution to oxidize trace unreacted DMDS/methanethiol. Do not over-oxidize or you will convert your product to the sulfoxide.
- Concentration: Rotovap with a bleach trap in the vacuum line.

Purification Strategy

Method	Suitability	Notes
Vacuum Distillation	High	Preferred for liquids. Requires high vacuum (<1 mbar) to keep pot temp <100°C. Risk of "bumping" due to sulfur impurities.
Crystallization	Low	Most methylthio furan esters are oils or low-melting solids. Only viable if the ester group is bulky (e.g., t-butyl).
Silica Plug	Medium	Good for removing polar impurities (sulfoxides). Use Hexane/EtOAc gradient.

Analytical Specifications (QC)

- HPLC Purity: >98.0% (AUC).
- ¹H NMR: Diagnostic singlet for -SMe at ~2.4-2.5 ppm; Furan doublets at ~6.4 and ~7.1 ppm.
- Residual Solvent: THF < 0.1% (ICH limit).
- Sulfated Ash: <0.1%.

Troubleshooting Guide

Problem: Low Yield / Recovery of Starting Material

- Root Cause:[\[3\]](#)[\[5\]](#)[\[6\]](#) Moisture in the system or insufficient deprotonation time.
- Fix: Ensure THF is distilled over Na/Benzophenone or passed through activated alumina. Increase Reactor 1 residence time slightly (e.g., 30s -> 45s).

Problem: Formation of Ketone (Nucleophilic Attack)

- Root Cause:[\[3\]](#)[\[5\]](#)[\[6\]](#) Base attacked the ester carbonyl instead of the ring proton.

- Fix: Switch from n-BuLi to LDA or LiTMP (non-nucleophilic bases). Lower the temperature of Reactor 1.

Problem: Product Oxidation (Sulfoxide formation)

- Root Cause:[3][5][6] Over-exposure to air or bleach during workup.
- Fix: Use mild oxidants only for waste streams, not product streams. Sparge all solvents with Nitrogen.

References

- Lithiation of Furan Derivatives
 - Organic Syntheses, Coll. Vol. 9, p. 559 (1998). "Regioselective Synthesis of Substituted Furans."
- Odor Control Engineering
 - Tri-Mer Corporation.[7] "Scrubbers for Methyl Mercaptan and Dimethyl Disulfide."
- Flow Chemistry for Organolithiums
 - Journal of Flow Chemistry, "Continuous flow synthesis of functionalized heterocycles via organolithium intermedi
- Safety Data & Handling
 - Chevron Phillips Chemical. "Dimethyl Disulfide (DMDS) Safety & Handling Guide."
- Structural Characterization
 - Molaid Chemicals. "Ethyl 5-((methylthio)methyl)

Need Custom Synthesis?

BenchChem offers custom synthesis for rare earth carbides and specific isotopic labeling.

Email: info@benchchem.com or [Request Quote Online](#).

Sources

- 1. Safety of dimethyl disulfide(DMDS) - Gansu Nabowang Chemical Products Co., Ltd [nbwchem.com]
- 2. Dimethyl disulfide: Toxicity, Applications, storage, Preparation_Chemicalbook [chemicalbook.com]
- 3. axxence.de [axxence.de]
- 4. cpchem.com [cpchem.com]
- 5. pureairfiltration.com [pureairfiltration.com]
- 6. mdpi.com [mdpi.com]
- 7. foodengineeringmag.com [foodengineeringmag.com]
- To cite this document: BenchChem. [Application Note: Scalable Synthesis of Methylthio-Substituted Furan Esters]. BenchChem, [2026]. [Online PDF]. Available at: [<https://www.benchchem.com/product/b11793463/docs#application-note-scalable-synthesis-of-methylthio-substituted-furan-esters>]

Disclaimer & Data Validity:

The information provided in this document is for Research Use Only (RUO) and is strictly not intended for diagnostic or therapeutic procedures. While BenchChem strives to provide accurate protocols, we make no warranties, express or implied, regarding the fitness of this product for every specific experimental setup.

Technical Support: The protocols provided are for reference purposes. Unsure if this reagent suits your experiment?

Need Industrial/Bulk Grade? [Request Custom Synthesis Quote](#)

BenchChem

Our mission is to be the trusted global source of essential and advanced chemicals, empowering scientists and researchers to drive progress in science and industry.

Contact

Address: 3281 E Guasti Rd

Ontario, CA 91761, United States

Phone: (601) 213-4426

Email: info@benchchem.com

[Contact our Ph.D. Support Team for a compatibility check](#)