

Technical Support Center: In Vitro Actin Polymerization Assays

Author: BenchChem Technical Support Team. **Date:** April 2026

Compound of Interest

Compound Name: *actA protein*
CAS No.: 144430-05-7
Cat. No.: B1179064

[Get Quote](#)

Welcome to the technical support center for in vitro actin polymerization assays. This resource is designed for researchers, scientists, and drug development professionals to troubleshoot common problems and provide clear guidance on experimental protocols and data interpretation.

Frequently Asked Questions (FAQs) & Troubleshooting

This section addresses specific issues that may arise during your experiments, presented in a question-and-answer format.

Section 1: Reagent and Sample Quality

Question: My actin is not polymerizing, or the polymerization is very slow in my positive control. What could be the cause?

Answer: This is a common issue that can often be traced back to the quality of the actin protein or other critical reagents. Here are several potential causes and solutions:

- **Actin Quality:** The quality and handling of the actin itself are paramount. Previously frozen G-actin can exhibit altered polymerization kinetics. It is highly recommended to use freshly prepared actin for each experiment. If using commercial lyophilized actin, ensure it is properly resuspended in G-buffer and clarified by ultracentrifugation to remove any aggregates or F-actin seeds.[1]
- **ATP and DTT Concentration:** Actin polymerization is dependent on ATP. Ensure that your buffers are freshly supplemented with ATP.[2][3] Additionally, a reducing agent like DTT is crucial for maintaining actin stability.[1][2] Prepare fresh ATP and DTT solutions for each experiment.
- **Buffer Composition:** The composition of your polymerization buffer (P-buffer) is critical. Incorrect pH, ionic strength, or a lack of Mg^{2+} can inhibit polymerization.[1] Prepare fresh buffers and double-check all component concentrations.
- **Actin Concentration:** The concentration of G-actin must be above the critical concentration (C_c) for polymerization to occur.[4][5] Verify the concentration of your actin stock using a protein assay or spectrophotometry.

Question: I'm observing a high initial fluorescence reading or a rapid increase in fluorescence without adding my test compound. Why is this happening?

Answer: This suggests spontaneous actin polymerization, which can obscure the effects of your protein of interest. Consider the following:

- **G-actin Stock Quality:** Your G-actin stock may contain F-actin fragments that act as nuclei, accelerating polymerization. To remedy this, ultracentrifuge your G-actin stock immediately before use to pellet any existing filaments.[1]
- **Polymerization Buffer Contamination:** The polymerization buffer should not contain divalent cations like Mg^{2+} or Ca^{2+} before you intend to initiate polymerization. The G-buffer should contain EGTA to chelate any contaminating Ca^{2+} . [6]
- **Temperature Control:** Perform the initial steps of the assay on ice to prevent premature polymerization. Pre-chill all reagents and equipment before starting the experiment.[6]

Section 2: Experimental Setup and Execution

Question: My results show high variability between replicates. What are the possible reasons?

Answer: Inconsistent results in actin polymerization assays often stem from minor variations in experimental technique. Here's what to look out for:

- **Pipetting Accuracy:** Actin polymerization is highly sensitive to small variations in protein concentrations.^[7] Ensure accurate and consistent pipetting, especially for viscous solutions.
- **Mixing and Timing:** Thorough and consistent mixing of all components is crucial. The timing of adding your test compound and initiating the measurement must be precise across all replicates.^[1] Avoid introducing air bubbles during mixing, as this can interfere with fluorescence readings.^[2]
- **Temperature Fluctuations:** Maintain a constant and uniform temperature throughout the experiment. If the sample starts cold and warms up during data collection, the kinetics will be affected.^[8]
- **Cuvette/Plate Cleanliness:** Dust or other particulates in the cuvette or wells can scatter light and cause a high background.^[1] Ensure your cuvettes or plates are clean.

Question: The fluorescence signal in my pyrene-actin assay is weak. How can I improve it?

Answer: A low fluorescence signal can make it difficult to accurately measure polymerization kinetics. Here are some ways to boost your signal:

- **Increase Pyrene-Labeled Actin Ratio:** A higher percentage of pyrene-labeled actin will result in a stronger signal. However, be aware that some actin-binding proteins may interact differently with pyrene-labeled actin.^[8] A range of 5-10% pyrene-labeled actin is commonly used.^[9]
- **Optimize Fluorometer Settings:** Increase the emission slit width or the photomultiplier tube (PMT) voltage on your fluorometer. Be cautious not to set the PMT voltage too high, as this can increase noise.^[8]

- Check Excitation and Emission Wavelengths: For pyrene-actin, the preferred excitation wavelength is around 365 nm, and the emission wavelength is typically around 407 nm.[8]

Troubleshooting Summary

The following table provides a quick reference for common problems, their potential causes, and recommended solutions.

Problem	Possible Causes	Recommended Solutions
No or Slow Polymerization	Inactive actin protein	Use freshly prepared, high-quality actin. Avoid repeated freeze-thaw cycles.
Incorrect buffer composition (pH, salt)	Prepare fresh polymerization buffer and verify the pH and ionic strength.	
Insufficient ATP or DTT	Add fresh ATP and DTT to your buffers immediately before use.	
Actin concentration below the critical concentration	Accurately determine and use an appropriate actin concentration.	
High Background Fluorescence	Pre-existing F-actin in G-actin stock	Ultracentrifuge G-actin stock before the assay to remove aggregates.
Contaminated buffers	Prepare fresh, filtered buffers.	
Dirty cuvettes or microplates	Thoroughly clean all experimental vessels.	
High Replicate Variability	Inaccurate pipetting	Calibrate pipettes and use reverse pipetting for viscous solutions.
Inconsistent mixing or timing	Standardize mixing technique and ensure precise timing between replicates.	
Temperature fluctuations	Use a temperature-controlled plate reader or water bath.	
Low Fluorescence Signal	Low percentage of pyrene-labeled actin	Increase the ratio of pyrene-labeled actin to unlabeled actin.

Suboptimal fluorometer settings	Adjust slit widths and PMT voltage.
Incorrect excitation/emission wavelengths	Verify the correct wavelengths for pyrene.

Experimental Protocol: Pyrene-Actin Polymerization Assay

This protocol provides a detailed methodology for a standard pyrene-based actin polymerization assay.

1. Reagent Preparation:

- G-buffer (Actin Monomer Buffer): 2 mM Tris-HCl pH 8.0, 0.2 mM ATP, 0.1 mM CaCl₂, 0.5 mM DTT.[8]
- 10x P-buffer (Polymerization Buffer): 500 mM KCl, 20 mM MgCl₂, 10 mM ATP.
- Actin Stock Preparation:
 - Resuspend lyophilized pyrene-labeled and unlabeled actin in G-buffer to a stock concentration of approximately 10-20 μM.[7]
 - Allow the actin to depolymerize on ice for at least 1 hour.
 - Clarify the actin solution by ultracentrifugation at >100,000 x g for 30 minutes at 4°C to remove any F-actin aggregates.[1]
 - Carefully collect the supernatant containing monomeric G-actin and determine its concentration. Keep on ice.

2. Assay Procedure:

- Prepare a master mix of G-actin containing the desired percentage of pyrene-labeled actin (typically 5-10%).

- In a microplate or cuvette, combine your test compound (or vehicle control) with the appropriate buffer.
- Add the G-actin master mix to each well or cuvette.
- To initiate polymerization, add 1/10th volume of 10x P-buffer to the reaction mixture.
- Mix quickly and gently by pipetting, being careful to avoid introducing air bubbles.[2]
- Immediately place the plate or cuvette in a pre-warmed fluorescence microplate reader or fluorometer.
- Measure the fluorescence intensity at regular intervals (e.g., every 30 seconds) for a duration sufficient to observe the full polymerization curve (lag phase, elongation phase, and plateau). The excitation wavelength should be ~365 nm and the emission wavelength ~407 nm.[8]

3. Data Analysis:

- Plot fluorescence intensity versus time.
- The resulting curve will show three distinct phases:
 - Lag Phase: The initial slow increase in fluorescence, representing the nucleation of actin filaments.[4][10]
 - Elongation Phase: The rapid, steep increase in fluorescence, corresponding to the elongation of actin filaments.[4][10]
 - Steady State (Plateau): The point at which the fluorescence signal levels off, indicating that the reaction has reached equilibrium between polymerization and depolymerization.[4][10]
- Key kinetic parameters such as the polymerization rate (the slope of the elongation phase) and the lag time can be calculated from these curves.

Visualizations

Actin Polymerization Phases

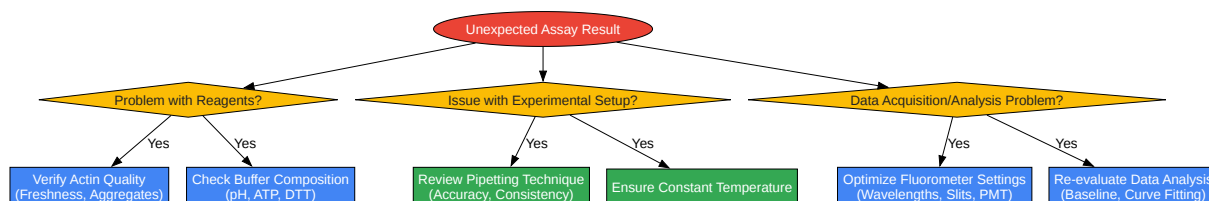
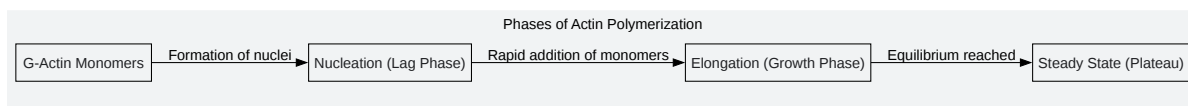

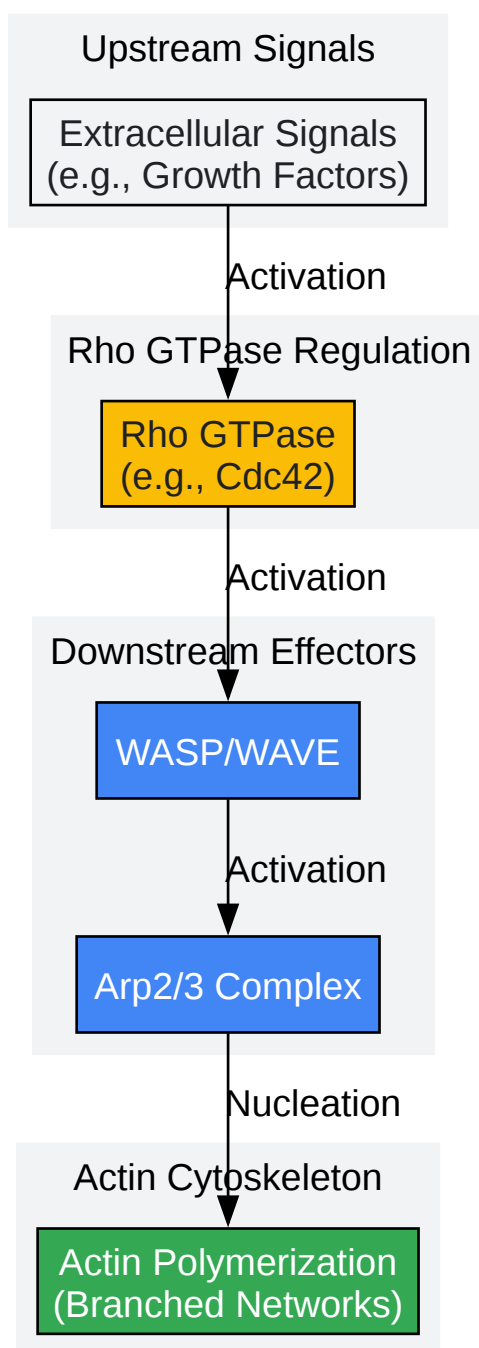

[Click to download full resolution via product page](#)

Need Custom Synthesis?

BenchChem offers custom synthesis for rare earth carbides and specific isotopic labeling.

Email: info@benchchem.com or [Request Quote Online](#).

References

- [1. benchchem.com \[benchchem.com\]](#)
- [2. In vitro Fluorescence Imaging–based Actin Bundling Assay - PMC \[pmc.ncbi.nlm.nih.gov\]](#)
- [3. Actin Polymerization/Depolymerization Assay Kit \(ab239724\) is not available | Abcam \[abcam.com\]](#)
- [4. Actin polymerization assay | Andex \[andexbiotech.com\]](#)
- [5. hypermol.com \[hypermol.com\]](#)
- [6. benchchem.com \[benchchem.com\]](#)
- [7. benchchem.com \[benchchem.com\]](#)
- [8. mullinslab.ucsf.edu \[mullinslab.ucsf.edu\]](#)
- [9. Measurement and Analysis of in vitro Actin Polymerization - PMC \[pmc.ncbi.nlm.nih.gov\]](#)
- [10. researchgate.net \[researchgate.net\]](#)
- To cite this document: BenchChem. [Technical Support Center: In Vitro Actin Polymerization Assays]. BenchChem, [2026]. [Online PDF]. Available at: [\[https://www.benchchem.com/product/b1179064/docs#technical-support-center-in-vitro-actin-polymerization-assays\]](https://www.benchchem.com/product/b1179064/docs#technical-support-center-in-vitro-actin-polymerization-assays)

Disclaimer & Data Validity:

The information provided in this document is for Research Use Only (RUO) and is strictly not intended for diagnostic or therapeutic procedures. While BenchChem strives to provide accurate protocols, we make no warranties, express or implied, regarding the fitness of this product for every specific experimental setup.

Technical Support: The protocols provided are for reference purposes. Unsure if this reagent suits your experiment?

Need Industrial/Bulk Grade? [Request Custom Synthesis Quote](#)

BenchChem

Our mission is to be the trusted global source of essential and advanced chemicals, empowering scientists and researchers to drive progress in science and industry.

Contact

Address: 3281 E Guasti Rd

Ontario, CA 91761, United States

Phone: (601) 213-4426

Email: info@benchchem.com

[Contact our Ph.D. Support Team for a compatibility check](#)