

Technical Support Center: Enhancing ActA Protein Crosslinking Efficiency

Author: BenchChem Technical Support Team. **Date:** April 2026

Compound of Interest

Compound Name: *actA protein*
CAS No.: 144430-05-7
Cat. No.: B1179064

[Get Quote](#)

This technical support center provides researchers, scientists, and drug development professionals with comprehensive troubleshooting guides and frequently asked questions (FAQs) to improve the efficiency of **ActA protein** crosslinking experiments.

Frequently Asked Questions (FAQs)

Q1: What is the function of **ActA protein** and why is crosslinking it important?

A1: ActA (Actin assembly-inducing protein) is a surface protein expressed by the intracellular pathogen *Listeria monocytogenes*. It plays a crucial role in bacterial motility within host cells by hijacking the host's actin cytoskeleton. ActA mimics host cell proteins to interact with and activate the Arp2/3 complex, which then nucleates the formation of actin filaments, creating a "comet tail" that propels the bacterium forward.[1][2] Crosslinking ActA to its binding partners, such as the Arp2/3 complex and VASP (Vasodilator-stimulated phosphoprotein), is essential for several reasons:

- **Mapping Interaction Sites:** It allows for the precise identification of the amino acid residues involved in the interaction between ActA and its host cell partners.

- **Stabilizing Transient Interactions:** The interactions between ActA and components of the actin polymerization machinery can be transient. Crosslinking captures these fleeting interactions, enabling their detection and analysis.
- **Structural Elucidation:** Crosslinking data provides distance constraints that are valuable for computational modeling of the three-dimensional structure of the ActA-Arp2/3 complex.

Q2: What are the main challenges when crosslinking the **ActA protein**?

A2: A significant challenge in crosslinking ActA is its nature as a natively unfolded protein.[1] This intrinsic disorder means that ActA lacks a stable three-dimensional structure in its unbound state, which can lead to several experimental difficulties:

- **Conformational Heterogeneity:** The flexibility of ActA can result in a heterogeneous population of crosslinked products, making analysis complex.
- **Accessibility of Reactive Residues:** The accessibility of amine or sulfhydryl groups for crosslinking can be variable and unpredictable.
- **Proteolytic Susceptibility:** Intrinsically disordered proteins are often more susceptible to degradation by proteases, which can be a concern during sample preparation.[3]

Q3: Which type of crosslinking reagent is best suited for studying ActA interactions?

A3: The choice of crosslinking reagent depends on the specific experimental goal. Here's a general guideline:

- **Homobifunctional Crosslinkers (e.g., DSS, BS3):** These have two identical reactive groups (e.g., NHS esters that react with primary amines). They are useful for initial screening of protein-protein interactions and for capturing complexes where the interacting partners have accessible amine groups in close proximity.[4]
- **Heterobifunctional Crosslinkers (e.g., SMCC):** These possess two different reactive groups (e.g., an NHS ester and a maleimide). They allow for a more controlled, two-step crosslinking process, which can reduce the formation of unwanted polymers. This is particularly useful when one protein has accessible amines and the other has accessible sulfhydryls.

- Zero-Length Crosslinkers (e.g., EDC): These reagents mediate the direct coupling of carboxyl groups to primary amines, forming a peptide bond with no additional spacer arm. They are ideal for identifying interactions where the reactive groups are in very close proximity.
- Photoreactive Crosslinkers: These reagents are activated by UV light and can react with a broader range of amino acid side chains, making them useful for capturing interactions that may not involve readily accessible primary amines or sulfhydryls. They can also be used for in vivo crosslinking.[\[5\]](#)[\[6\]](#)

Troubleshooting Guide

| Problem | Possible Cause | Suggested Solution |
|--|--|---|
| Low or No Crosslinking Efficiency | Suboptimal Buffer Conditions: Buffer contains primary amines (e.g., Tris, glycine) that compete with the protein for reaction with amine-reactive crosslinkers.[4][7] | Use a non-amine-containing buffer such as PBS (Phosphate-Buffered Saline) or HEPES at a pH of 7.0-8.5 for NHS-ester based crosslinkers. [4] |
| Incorrect Molar Excess of Crosslinker: Insufficient crosslinker concentration to drive the reaction forward, especially with dilute protein samples. | Perform a titration experiment to determine the optimal molar excess of crosslinker to protein. Start with a 20- to 50-fold molar excess for protein concentrations below 1 mg/mL. | |
| Hydrolysis of Crosslinker: NHS-ester containing crosslinkers are moisture-sensitive and can hydrolyze, rendering them inactive. | Prepare the crosslinker stock solution in an anhydrous organic solvent like DMSO or DMF immediately before use. Avoid storing stock solutions for extended periods.[4] | |
| Inaccessible Reactive Groups on ActA or its Binding Partner: The primary amines or other target functional groups are buried within the protein structure or at the interaction interface. | Consider using a crosslinker with a longer spacer arm to bridge more distant reactive groups. Alternatively, a photoreactive crosslinker that reacts with a wider range of amino acids could be employed.[7] | |
| Protein Aggregation or Precipitation | Excessive Crosslinking: High concentrations of crosslinker can lead to the formation of large, insoluble aggregates due to extensive intermolecular crosslinking. | Reduce the molar excess of the crosslinker. A shorter reaction time or lower temperature may also help to control the extent of crosslinking. |

| | | |
|--|---|---|
| <p>High Protein Concentration: Concentrated protein solutions are more prone to aggregation upon the addition of a crosslinker.</p> | <p>Reduce the protein concentration. Perform the crosslinking reaction at a lower temperature (e.g., on ice or at 4°C).</p> | |
| <p>Solvent Incompatibility: The organic solvent used to dissolve the crosslinker (e.g., DMSO) may cause the protein to precipitate when added to the aqueous buffer.</p> | <p>Add the crosslinker solution dropwise to the protein solution while gently vortexing to ensure rapid mixing and minimize local high concentrations of the organic solvent.</p> | |
| <p>Non-specific Crosslinking</p> | <p>Long Reaction Time: Extended incubation with the crosslinker can lead to the capture of non-specific, transient interactions.</p> | <p>Optimize the reaction time. For many crosslinkers, an incubation of 30 minutes to 1 hour at room temperature is sufficient.</p> |
| <p>High Crosslinker Concentration: As with aggregation, excessive crosslinker can increase the likelihood of random, non-specific crosslinks.</p> | <p>Use the lowest effective concentration of the crosslinker as determined by a titration experiment.</p> | |
| <p>Difficulty Analyzing Crosslinked Products</p> | <p>Heterogeneity of Crosslinked Species: Due to ActA's disordered nature, a wide range of crosslinked products may be formed, leading to smeared bands on an SDS-PAGE gel.</p> | <p>Consider using a two-step crosslinking approach with a heterobifunctional reagent to gain more control over the reaction. Analysis by mass spectrometry will be crucial for identifying specific crosslinked peptides.</p> |
| <p>Cleavable vs. Non-cleavable Crosslinkers: Non-cleavable crosslinkers can make mass</p> | <p>Use a mass spectrometry-cleavable crosslinker (e.g., those with a disulfide bond) to</p> | |

spectrometry analysis
challenging.

simplify the identification of
crosslinked peptides.

Quantitative Data Summary

Optimizing the molar excess of the crosslinking reagent to the protein is critical for achieving efficient crosslinking without causing excessive aggregation. The ideal ratio is dependent on the protein concentration.

| Protein Concentration | Recommended Molar Excess (Crosslinker:Protein) |
|-----------------------|---|
| > 5 mg/mL | 5x to 20x |
| 1-5 mg/mL | 20x to 50x |
| < 1 mg/mL | 50x to 100x |

Note: This is a general guideline. The optimal molar excess should be determined empirically for each specific protein system and crosslinker.

Experimental Protocols

Protocol 1: In Vitro Crosslinking of Purified ActA with Arp2/3 Complex using DSS

This protocol describes the crosslinking of purified, soluble ActA (or a fragment thereof) with the purified Arp2/3 complex using the homobifunctional, amine-reactive crosslinker Disuccinimidyl suberate (DSS).

Materials:

- Purified **ActA protein**
- Purified Arp2/3 complex
- DSS (Disuccinimidyl suberate)

- Anhydrous DMSO (Dimethyl sulfoxide)
- Crosslinking Buffer: 20 mM HEPES, pH 7.5, 100 mM KCl, 1 mM MgCl₂, 1 mM EGTA
- Quenching Solution: 1 M Tris-HCl, pH 7.5
- SDS-PAGE loading buffer

Procedure:

- Protein Preparation:
 - Dialyze the purified ActA and Arp2/3 complex into the Crosslinking Buffer to remove any primary amine-containing contaminants.
 - Determine the protein concentrations using a suitable method (e.g., Bradford assay).
 - Prepare a reaction mixture containing ActA and the Arp2/3 complex at the desired molar ratio (a 1:1 ratio is a good starting point) in a microcentrifuge tube. The final protein concentration should ideally be in the range of 1-5 mg/mL.
- DSS Preparation:
 - Immediately before use, prepare a 25 mM stock solution of DSS in anhydrous DMSO.
- Crosslinking Reaction:
 - Add the DSS stock solution to the protein mixture to achieve the desired final molar excess (refer to the table above). For a 20-fold molar excess with a 1 mg/mL protein solution, this would be a small volume of the DSS stock.
 - Mix gently by pipetting up and down.
 - Incubate the reaction at room temperature for 30 minutes.
- Quenching the Reaction:
 - Add the Quenching Solution to a final concentration of 20-50 mM Tris.

- Incubate for an additional 15 minutes at room temperature to quench any unreacted DSS.
- Analysis:
 - Add SDS-PAGE loading buffer to the quenched reaction mixture.
 - Analyze the crosslinked products by SDS-PAGE followed by Coomassie staining or Western blotting using antibodies specific for ActA and a subunit of the Arp2/3 complex. The appearance of higher molecular weight bands corresponding to the ActA-Arp2/3 complex indicates successful crosslinking.
 - For more detailed analysis of the crosslinked sites, the sample can be processed for mass spectrometry.

Protocol 2: In Vivo Crosslinking of ActA in *Listeria monocytogenes*

This protocol describes the crosslinking of ActA to its interacting partners within the context of an infected host cell using a membrane-permeable crosslinker.

Materials:

- *Listeria monocytogenes* strain expressing ActA
- Mammalian cell line for infection (e.g., HeLa cells)
- Cell culture medium
- Membrane-permeable crosslinker (e.g., DSP - Dithiobis(succinimidyl propionate))
- PBS (Phosphate-Buffered Saline)
- Lysis Buffer (e.g., RIPA buffer with protease inhibitors)
- Quenching Solution: 1 M Tris-HCl, pH 7.5

Procedure:

- Cell Infection:
 - Seed the mammalian cells in a culture plate and grow to the desired confluency.
 - Infect the cells with *Listeria monocytogenes* at an appropriate multiplicity of infection (MOI) and incubate to allow for bacterial entry and intracellular replication.
- Crosslinking:
 - Wash the infected cells three times with ice-cold PBS to remove the culture medium.
 - Add the crosslinker dissolved in PBS to the cells. A final concentration of 1-2 mM DSP is a common starting point.
 - Incubate at room temperature for 30 minutes.
- Quenching:
 - Remove the crosslinker solution and wash the cells once with PBS.
 - Add the Quenching Solution to the cells and incubate for 15 minutes at room temperature.
- Cell Lysis and Analysis:
 - Wash the cells again with PBS and then lyse the cells using an appropriate Lysis Buffer.
 - Clarify the lysate by centrifugation.
 - The crosslinked complexes can then be analyzed by immunoprecipitation using an antibody against ActA, followed by SDS-PAGE and Western blotting to detect co-precipitated binding partners.

Visualizations

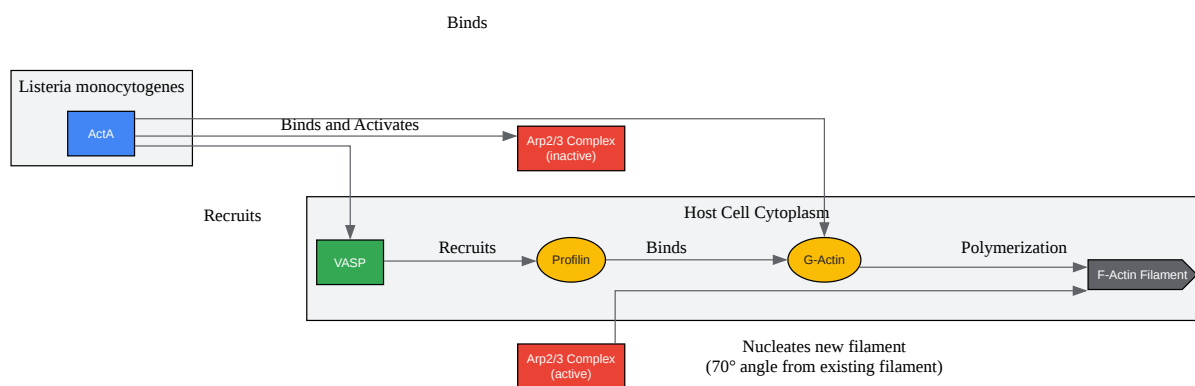

[Click to download full resolution via product page](#)

Caption: ActA-mediated actin polymerization signaling pathway.

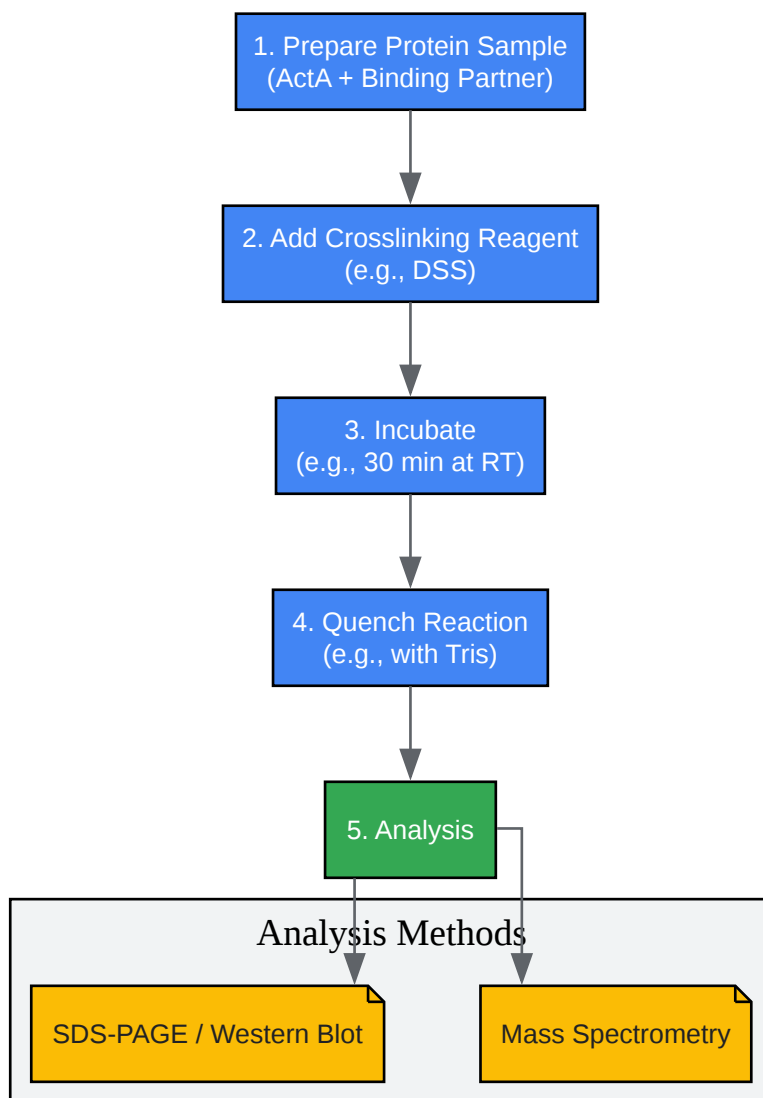

[Click to download full resolution via product page](#)

Caption: General workflow for in vitro protein crosslinking.

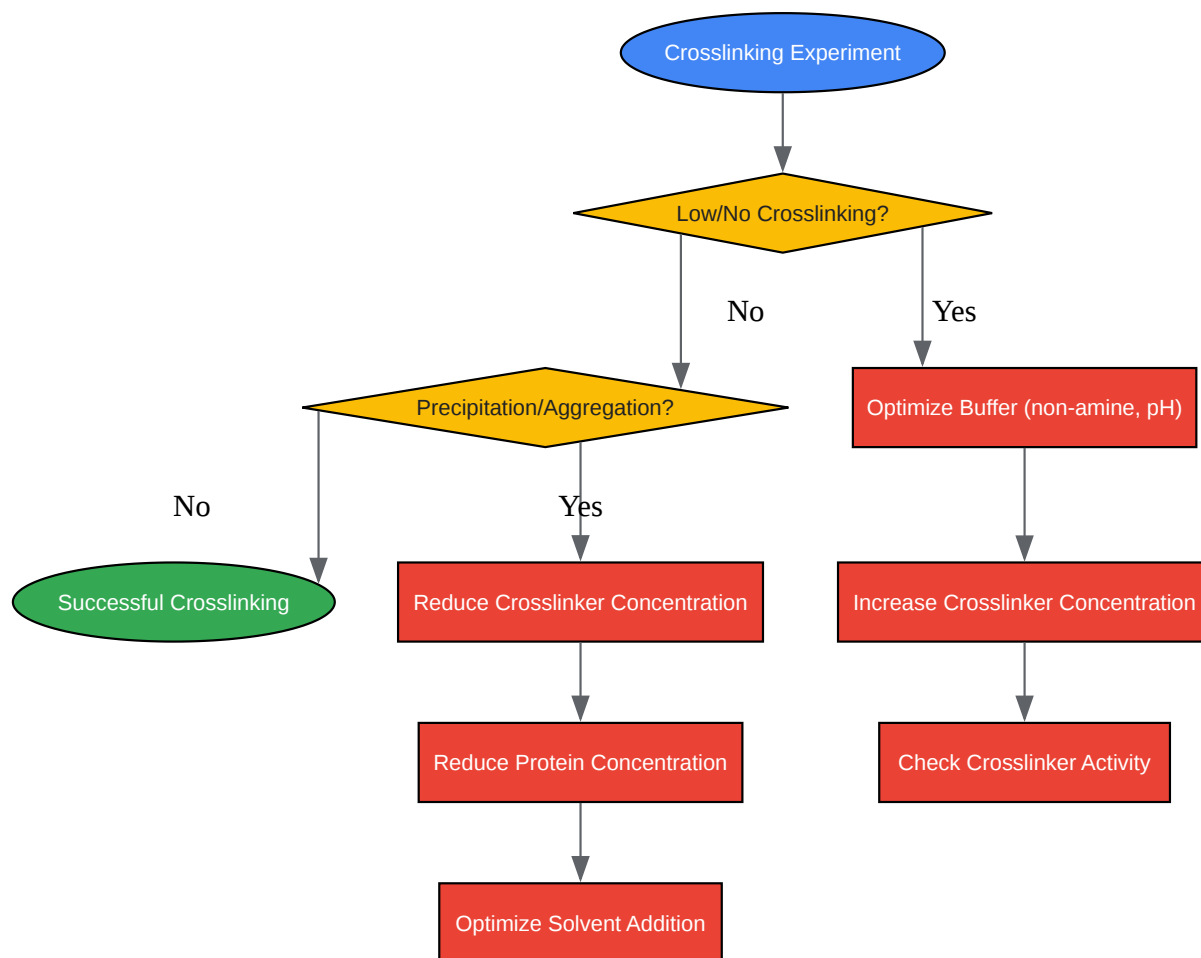

[Click to download full resolution via product page](#)

Caption: Troubleshooting logic for **ActA protein** crosslinking.

Need Custom Synthesis?

BenchChem offers custom synthesis for rare earth carbides and specific isotopic labeling.

Email: info@benchchem.com or [Request Quote Online](#).

References

- [1. Actin assembly-inducing protein - Wikipedia \[en.wikipedia.org\]](#)
- [2. Actin-Based Motility of Intracellular Microbial Pathogens - PMC \[pmc.ncbi.nlm.nih.gov\]](#)
- [3. Troubleshooting Guide to Expressing Intrinsically Disordered Proteins for Use in NMR Experiments - PubMed \[pubmed.ncbi.nlm.nih.gov\]](#)
- [4. benchchem.com \[benchchem.com\]](#)
- [5. Photo-reactive amino acid analog - Wikipedia \[en.wikipedia.org\]](#)
- [6. Photoreactive Amino Acids: Mechanisms, Synthesis, Applications, Detection and Challenges - Creative Proteomics \[creative-proteomics.com\]](#)
- [7. Protein Labeling, Crosslinking, and Modification Support—Troubleshooting | Thermo Fisher Scientific - SG \[thermofisher.com\]](#)
- To cite this document: BenchChem. [Technical Support Center: Enhancing ActA Protein Crosslinking Efficiency]. BenchChem, [2026]. [Online PDF]. Available at: [\[https://www.benchchem.com/product/b1179064/docs#technical-support-center-enhancing-acta-protein-crosslinking-efficiency\]](https://www.benchchem.com/product/b1179064/docs#technical-support-center-enhancing-acta-protein-crosslinking-efficiency)

Disclaimer & Data Validity:

The information provided in this document is for Research Use Only (RUO) and is strictly not intended for diagnostic or therapeutic procedures. While BenchChem strives to provide accurate protocols, we make no warranties, express or implied, regarding the fitness of this product for every specific experimental setup.

Technical Support: The protocols provided are for reference purposes. Unsure if this reagent suits your experiment?

Need Industrial/Bulk Grade? [Request Custom Synthesis Quote](#)

BenchChem

Our mission is to be the trusted global source of essential and advanced chemicals, empowering scientists and researchers to drive progress in science and industry.

Contact

Address: 3281 E Guasti Rd
Ontario, CA 91761, United States
Phone: (601) 213-4426
Email: info@benchchem.com

Contact our Ph.D. Support Team for a compatibility check