

1,4-Bis(2-Hydroxyethoxy)-2-Butyne as a chain extender protocol

Author: BenchChem Technical Support Team. **Date:** May 2026

Compound of Interest

Compound Name:	1,4-Bis(2-Hydroxyethoxy)-2-Butyne
CAS No.:	1605-85-5
Cat. No.:	B1179979

[Get Quote](#)

Application Note: Protocol for Using **1,4-Bis(2-Hydroxyethoxy)-2-Butyne** as a Functional Chain Extender in Polyurethane Synthesis

Abstract

This guide details the protocol for utilizing **1,4-Bis(2-hydroxyethoxy)-2-butyne** (BHEB) (CAS: 1606-85-5) as a chain extender in the synthesis of functionalized polyurethanes (PUs). Unlike standard extenders (e.g., 1,4-butanediol), BHEB incorporates a reactive internal alkyne moiety into the polymer backbone. This "chemical handle" enables post-polymerization modification via copper-catalyzed azide-alkyne cycloaddition (CuAAC) or thiol-yne chemistry, facilitating the attachment of bioactive ligands, fluorophores, or cross-linking agents.

Introduction & Mechanistic Rationale

1,4-Bis(2-hydroxyethoxy)-2-butyne is a diol chain extender characterized by two primary hydroxyl groups separated by ethoxy spacers and a central alkyne unit.

- Structure:

- Role in Synthesis: It reacts with diisocyanates (e.g., MDI, HDI) to form the "hard segment" of the polyurethane.
- Key Advantages:
 - Liquid State: Unlike its precursor 2-butyne-1,4-diol (a solid), BHEB is a viscous liquid at room temperature, simplifying processing and blending.
 - Reactivity: The ethoxy spacers provide primary hydroxyls with reduced steric hindrance compared to the alkyne-adjacent hydroxyls, ensuring reaction rates comparable to 1,4-butanediol (BDO).
 - Functional Handle: The internal triple bond remains inert during urethane formation but is highly reactive toward azides and thiols for downstream functionalization.

Material Characterization & Preparation

Table 1: Physical Properties of BHEB

Property	Value	Relevance
Molecular Weight	174.19 g/mol	Required for stoichiometric calculations ().
Equivalent Weight	87.10 g/eq	Mass containing 1 mole of hydroxyl groups.
Physical State	Viscous Yellow/Brown Liquid	Easy to dispense; may require heating to lower viscosity.
Boiling Point	~225°C	High thermal stability for PU curing.
Hygroscopicity	High	CRITICAL: Must be dried before use to prevent urea formation.

Preparation Step:

- Dehydration: BHEB is hygroscopic. Prior to synthesis, dry the BHEB under vacuum (<1 mbar) at 60°C for at least 4 hours. Verify water content is <0.05% using Karl Fischer titration.

Experimental Protocols

Protocol A: Two-Step Prepolymer Synthesis (Recommended)

Best for controlling structure regularity and minimizing heat buildup.

Reagents:

- Polyol: PTMEG (MW 1000 or 2000) or Polyester polyol (dried).
- Isocyanate: 4,4'-MDI or HDI.[\[1\]](#)
- Chain Extender: BHEB (dried).
- Catalyst: Dibutyltin Dilaurate (DBTDL) (0.01–0.05 wt%).
- Solvent (Optional): Anhydrous DMF or DMAc (if solution polymerization is required).

Workflow:

- Prepolymer Formation:
 - Charge the dried polyol into a reaction kettle equipped with mechanical stirring, nitrogen inlet, and temperature control.
 - Heat to 60°C.
 - Add Isocyanate (MDI) in excess. The molar ratio of NCO (Isocyanate) to OH (Polyol) should be calculated to target a specific %NCO content (typically 2:1 for strict prepolymers).
 - Reaction: Stir at 80°C for 2 hours under

- Validation: Titrate free NCO (ASTM D2572) to confirm theoretical conversion.
- Chain Extension (The BHEB Step):
 - Calculate the required mass of BHEB:

(Index is typically 0.98–1.02).
 - Degas the BHEB liquid and add it to the prepolymer under rapid stirring.
 - Note: The viscosity will rise rapidly. If doing bulk polymerization, pour the mixture into a pre-heated Teflon mold (100°C) immediately upon homogeneity (approx. 30-60 seconds).
 - Curing: Cure at 100°C for 16–24 hours.

Protocol B: Post-Polymerization "Click" Functionalization

Attaching a functional molecule (e.g., Azide-Fluorophore) to the PU backbone.

Reagents:

- PU-BHEB Film: The polymer synthesized in Protocol A.
- Ligand: Azide-functionalized molecule ().
- Catalyst: CuBr / PMDETA (Pentamethyldiethylenetriamine).
- Solvent: DMF or THF (swelling solvent).

Workflow:

- Swelling: Swell the PU film in the solvent for 1 hour.

- Catalyst Mix: Dissolve CuBr (5 mol% relative to alkyne) and PMDETA (5 mol%) in the solvent under inert atmosphere.
- Reaction: Add the Azide-Ligand (1.1 equiv) and catalyst solution to the swollen film.
- Incubation: Shake gently at 40°C for 12–24 hours.
- Washing: Remove film and wash extensively with EDTA solution (to remove Copper) and fresh solvent (to remove unreacted ligand).

Pathway Visualization

The following diagram illustrates the chemical incorporation of BHEB and its subsequent functionalization.

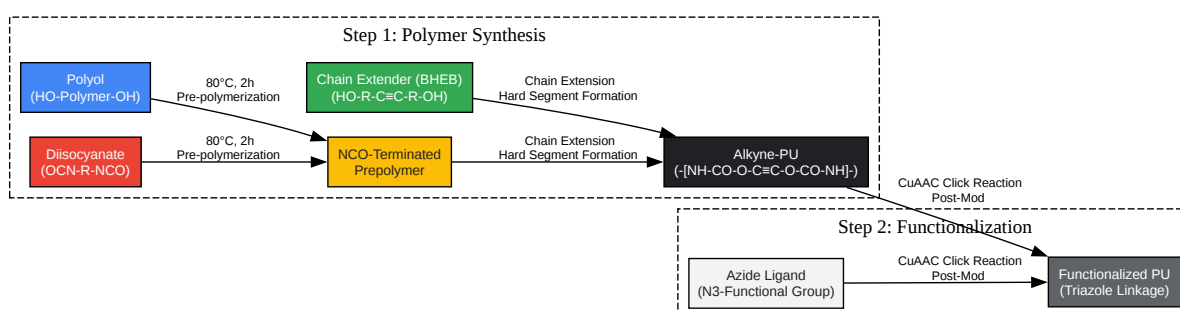

[Click to download full resolution via product page](#)

Caption: Synthesis workflow showing the incorporation of BHEB into the PU backbone followed by post-polymerization click chemistry.

Troubleshooting & Optimization

Issue	Probable Cause	Corrective Action
Bubbles in Final Film	Moisture in BHEB or Polyol	Re-dry BHEB at 60°C under vacuum. Use molecular sieves for solvents.
Low Mechanical Strength	Incorrect Stoichiometry	Re-titrate Isocyanate NCO content. Ensure BHEB weight is precise.
Film Opaque/Phase Separation	Incompatibility	BHEB is polar. If using non-polar polyols (e.g., Polybutadiene), add a compatibilizer or use a co-extender (e.g., BDO).
No "Click" Reaction	Catalyst Poisoning / Sterics	Ensure Copper catalyst is Oxygen-free (green/blue indicates oxidation; should be clear/brown). Swell film adequately.

Safety & Handling

- Isocyanate Hazard: MDI/HDI are respiratory sensitizers. All reactions must be performed in a fume hood.
- BHEB Handling: While less volatile than BDO, BHEB is an irritant. Wear nitrile gloves and eye protection.
- Copper Catalyst: Copper(I) is toxic to aquatic life. Dispose of wash buffers (EDTA) as hazardous heavy metal waste.

References

- MDPI. (2023). Effect of Chain Extenders on Polyurea and Polyurethane Coatings. *Polymers*. Retrieved October 24, 2023, from [\[Link\]](#)

- ResearchGate. (2023). Reaction of OH with Aliphatic and Aromatic Isocyanates. Retrieved October 24, 2023, from [\[Link\]](#)
- PubChem. (n.d.). **1,4-Bis(2-hydroxyethoxy)-2-butyne** Compound Summary. National Library of Medicine. Retrieved October 24, 2023, from [\[Link\]](#)

Need Custom Synthesis?

BenchChem offers custom synthesis for rare earth carbides and specific isotopic labeling.

Email: info@benchchem.com or [Request Quote Online](#).

Sources

- [1. researchgate.net \[researchgate.net\]](https://www.researchgate.net)
- To cite this document: BenchChem. [1,4-Bis(2-Hydroxyethoxy)-2-Butyne as a chain extender protocol]. BenchChem, [2026]. [Online PDF]. Available at: [\[https://www.benchchem.com/product/b1179979/docs#1-4-bis-2-hydroxyethoxy-2-butyne-as-a-chain-extender-protocol\]](https://www.benchchem.com/product/b1179979/docs#1-4-bis-2-hydroxyethoxy-2-butyne-as-a-chain-extender-protocol)

Disclaimer & Data Validity:

The information provided in this document is for Research Use Only (RUO) and is strictly not intended for diagnostic or therapeutic procedures. While BenchChem strives to provide accurate protocols, we make no warranties, express or implied, regarding the fitness of this product for every specific experimental setup.

Technical Support: The protocols provided are for reference purposes. Unsure if this reagent suits your experiment?

Need Industrial/Bulk Grade? [Request Custom Synthesis Quote](#)

BenchChem

Our mission is to be the trusted global source of essential and advanced chemicals, empowering scientists and researchers to drive progress in science and industry.

Contact

Address: 3281 E Guasti Rd

Ontario, CA 91761, United States

Phone: (601) 213-4426

Email: info@benchchem.com

[Contact our Ph.D. Support Team for a compatibility check](#)