

Application Notes and Protocols for the Synthesis of Furopyridines

Author: BenchChem Technical Support Team. **Date:** May 2026

Compound of Interest

Compound Name: 4-(*tert*-Butyl)furo[3,2-*c*]pyridine-2-carbaldehyde

Cat. No.: B11789535

[Get Quote](#)

For Researchers, Scientists, and Drug Development Professionals

Authored by: Your Senior Application Scientist

Abstract

The furopyridine scaffold, a privileged heterocyclic motif, is of paramount importance in medicinal chemistry and materials science due to its prevalence in numerous biologically active compounds and functional materials. The fusion of a π -excessive furan ring with a π -deficient pyridine ring imparts unique physicochemical properties that are highly sought after in drug design. This comprehensive guide provides an in-depth exploration of the primary synthetic strategies for constructing the furopyridine core. We will delve into the mechanistic underpinnings of key methodologies, including transition-metal-catalyzed cross-coupling and cyclization reactions, traditional intramolecular cyclizations, and modern multicomponent reactions. This document is designed to be a practical resource, offering detailed, step-by-step protocols, quantitative data on substrate scope and yields, and visual diagrams to elucidate reaction pathways and workflows.

Introduction: The Significance of the Furopyridine Core

Furopyridines are bicyclic heteroaromatic compounds that have garnered significant attention from the scientific community. Their structural rigidity and unique electronic properties make them ideal candidates for interaction with various biological targets. The nitrogen atom in the pyridine ring can act as a hydrogen bond acceptor, enhancing binding affinity to proteins, while the overall structure often leads to improved pharmacokinetic profiles compared to their benzofuran counterparts.[1] Consequently, furopyridine derivatives have been investigated for a wide range of therapeutic applications, including as anticancer agents, antivirals, and kinase inhibitors.[2][3] The diverse biological activities exhibited by this class of compounds underscore the need for robust and versatile synthetic methods to access a wide array of substituted furopyridine analogues for structure-activity relationship (SAR) studies.

This guide will focus on the most prevalent and effective strategies for the synthesis of various furopyridine isomers, including furo[2,3-b]-, furo[3,2-b]-, furo[2,3-c]-, and furo[3,2-c]pyridines.

Strategic Approaches to Furopyridine Synthesis

The construction of the furopyridine skeleton can be broadly categorized into two main approaches:

- **Strategy A: Furan Ring Formation on a Pre-formed Pyridine Core:** This is a widely utilized strategy due to the vast commercial availability of substituted pyridine starting materials.
- **Strategy B: Pyridine Ring Annulation onto a Pre-existing Furan Moiety:** This approach is valuable when the desired substitution pattern on the furan ring is more readily accessible from furan precursors.

Beyond these two primary strategies, multicomponent reactions have emerged as a powerful tool for the rapid assembly of complex furopyridine structures in a single step.

Transition-Metal-Catalyzed Synthesis of Furopyridines

Transition-metal catalysis has revolutionized the synthesis of complex heterocyclic systems, and furopyridines are no exception. Palladium, gold, and copper catalysts are frequently employed to facilitate key bond-forming reactions with high efficiency and selectivity.

Palladium-Catalyzed Sonogashira Coupling and Cyclization

A powerful method for the synthesis of furo[3,2-b] and furo[2,3-b]pyridines involves a palladium-catalyzed Sonogashira coupling of a halogenated hydroxypyridine with a terminal alkyne, followed by an intramolecular cyclization.

Causality Behind Experimental Choices:

- **Catalyst System:** A combination of a palladium catalyst (e.g., Pd(OAc)₂, Pd/C) and a copper(I) co-catalyst (e.g., CuI) is crucial for the Sonogashira reaction. The palladium complex facilitates the oxidative addition to the aryl halide and the reductive elimination to form the C-C bond, while the copper(I) salt is believed to form a copper acetylide intermediate, which then undergoes transmetalation with the palladium center.
- **Ligands:** Phosphine ligands, such as triphenylphosphine (PPh₃), are often used to stabilize the palladium catalyst and modulate its reactivity.
- **Base:** A base, typically an amine like triethylamine (Et₃N), is required to deprotonate the terminal alkyne and neutralize the hydrogen halide formed during the reaction.
- **Solvent:** Polar aprotic solvents like DMF or alcohols such as ethanol are commonly used to dissolve the reactants and catalysts.

Reaction Mechanism: Sonogashira Coupling and Cyclization

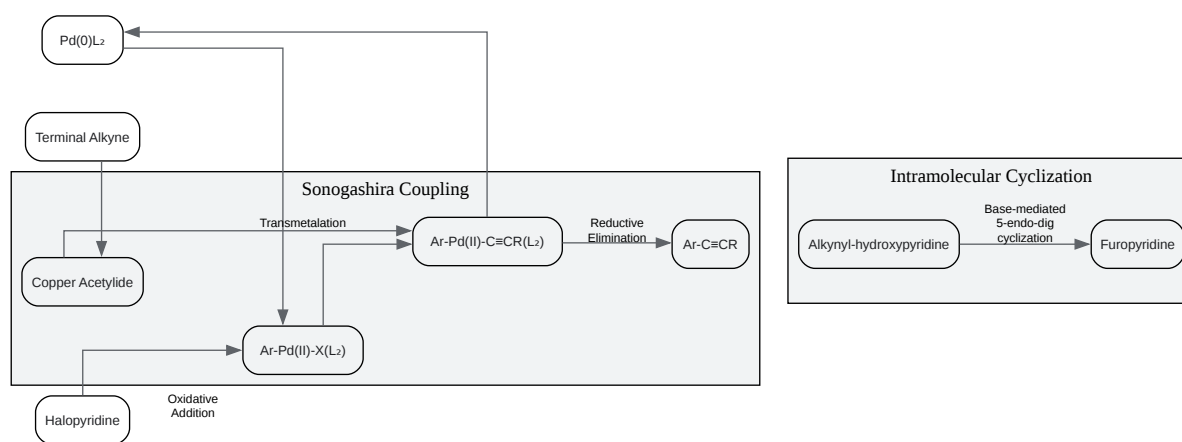

[Click to download full resolution via product page](#)

Caption: Palladium-catalyzed Sonogashira coupling followed by cyclization.

Detailed Protocol for the Synthesis of 2-Substituted Furo[3,2-b]pyridines[4][5]

- **Reaction Setup:** To a solution of 3-chloro-2-hydroxypyridine (1.0 mmol) and a terminal alkyne (1.1 mmol) in ethanol (10 mL), add 10% Pd/C (0.05 mmol), CuI (0.05 mmol), PPh_3 (0.1 mmol), and Et_3N (2.0 mmol).
- **Reaction Conditions:** Subject the reaction mixture to ultrasound irradiation at room temperature until the reaction is complete (monitored by TLC).
- **Work-up and Purification:** Upon completion, remove the solvent under reduced pressure. Purify the residue by column chromatography on silica gel using a suitable eluent (e.g., ethyl acetate/hexanes) to afford the desired 2-substituted furo[3,2-b]pyridine.

Table 1: Substrate Scope and Yields for Palladium-Catalyzed Synthesis of Furo[3,2-b]pyridines[5][6]

Entry	Halopyridine	Alkyne	Product	Yield (%)
1	3-chloro-2-hydroxypyridine	Phenylacetylene	2-Phenylfuro[3,2-b]pyridine	85
2	3-chloro-2-hydroxypyridine	1-Hexyne	2-Butylfuro[3,2-b]pyridine	78
3	2-amino-3-bromopyridine	4-Methylphenylacetylene	2-Amino-3-(4-methylphenylethynyl)pyridine	87
4	2-amino-3-bromopyridine	4-Propylphenylacetylene	2-Amino-3-(4-propylphenylethynyl)pyridine	85

Gold-Catalyzed Intramolecular Cyclization

Gold catalysts, particularly Au(I) and Au(III) complexes, are highly effective in activating alkynes towards nucleophilic attack. This property has been exploited for the synthesis of furopyridines through the intramolecular cyclization of appropriately substituted pyridine derivatives bearing an alkyne moiety.

Causality Behind Experimental Choices:

- **Gold Catalyst:** Cationic gold(I) complexes are excellent π -acids, readily coordinating to the alkyne and rendering it susceptible to nucleophilic attack by a tethered hydroxyl or amino group.
- **Solvent:** Chlorinated solvents such as dichloromethane (DCM) or 1,2-dichloroethane (DCE) are often used for gold-catalyzed reactions.

Reaction Mechanism: Gold-Catalyzed Intramolecular Cyclization

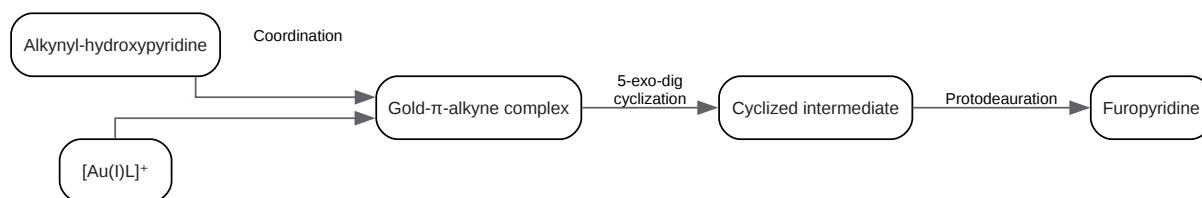

[Click to download full resolution via product page](#)

Caption: Gold-catalyzed intramolecular cyclization of an alkynyl-hydroxypyridine.

Detailed Protocol for Gold-Catalyzed Synthesis of Furo[2,3-c]isoquinolines[7]

- **Reaction Setup:** To a solution of the starting diynamide (0.2 mmol) in DCE (2.0 mL) is added a solution of the gold catalyst (e.g., JohnphosAu(MeCN)SbF₆, 5 mol%).
- **Reaction Conditions:** The reaction mixture is stirred at 80 °C for the specified time (monitored by TLC).
- **Work-up and Purification:** After cooling to room temperature, the solvent is removed under reduced pressure, and the residue is purified by column chromatography on silica gel to afford the desired furopyridine derivative.

Intramolecular Cyclization Strategies

Thorpe-Ziegler Cyclization for Furo[2,3-b]pyridines

The Thorpe-Ziegler reaction is a classic method for the formation of cyclic ketones and enamines through the base-catalyzed intramolecular condensation of dinitriles. This strategy has been adapted for the synthesis of furo[2,3-b]pyridines.

Causality Behind Experimental Choices:

- **Starting Material:** A 3-cyano-2-pyridone derivative with a suitable side chain containing a nitrile group is required.
- **Base:** A strong, non-nucleophilic base such as sodium hydride (NaH) or potassium tert-butoxide (t-BuOK) is used to deprotonate the active methylene group adjacent to one of the

nitrile functions.

- Solvent: Anhydrous aprotic solvents like DMF or THF are essential to prevent quenching of the carbanion intermediate.

Reaction Mechanism: Thorpe-Ziegler Cyclization

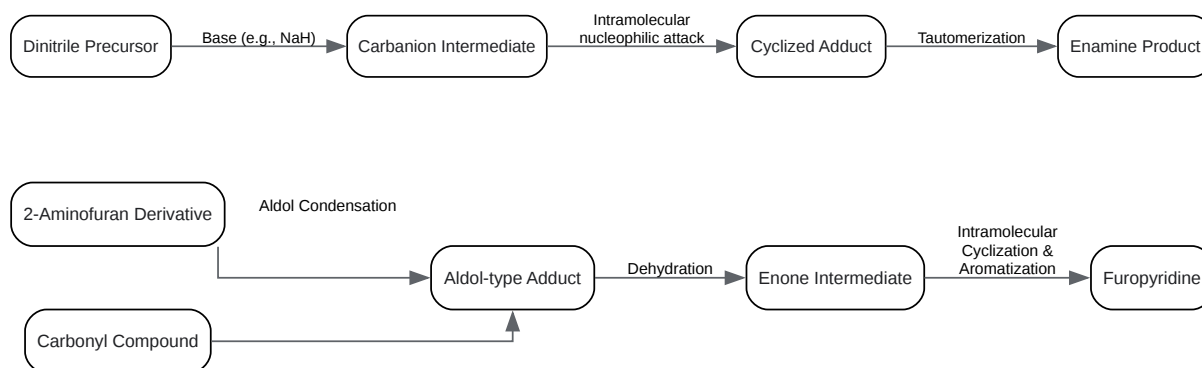

[Click to download full resolution via product page](#)

Need Custom Synthesis?

BenchChem offers custom synthesis for rare earth carbides and specific isotopic labeling.

Email: info@benchchem.com or [Request Quote Online](#).

Sources

1. Multicomponent reactions (UGI, Passerini, Biginelli) | PPTX [slideshare.net]
2. researchgate.net [researchgate.net]
3. Synthesis and cytotoxicity of thieno[2,3-b]pyridine and furo[2,3-b]pyridine derivatives - PubMed [pubmed.ncbi.nlm.nih.gov]
4. encyclopedia.pub [encyclopedia.pub]
5. Synthesis of 2-substituted Furo[3,2-b]pyridines Under Pd/C-Cu Catalysis Assisted by Ultrasound: Their Evaluation as Potential Cytotoxic Agents - PubMed [pubmed.ncbi.nlm.nih.gov]

- [6. Palladium-Catalyzed Sonogashira Coupling Reaction of 2-Amino-3-Bromopyridines with Terminal Alkynes \[scirp.org\]](#)
- [7. beckassets.blob.core.windows.net \[beckassets.blob.core.windows.net\]](#)
- To cite this document: BenchChem. [Application Notes and Protocols for the Synthesis of Furopyridines]. BenchChem, [2026]. [Online PDF]. Available at: [\[https://www.benchchem.com/product/b11789535/docs#application-notes-and-protocols-for-the-synthesis-of-furopyridines\]](https://www.benchchem.com/product/b11789535/docs#application-notes-and-protocols-for-the-synthesis-of-furopyridines)

Disclaimer & Data Validity:

The information provided in this document is for Research Use Only (RUO) and is strictly not intended for diagnostic or therapeutic procedures. While BenchChem strives to provide accurate protocols, we make no warranties, express or implied, regarding the fitness of this product for every specific experimental setup.

Technical Support: The protocols provided are for reference purposes. Unsure if this reagent suits your experiment?

Need Industrial/Bulk Grade? [Request Custom Synthesis Quote](#)

BenchChem

Our mission is to be the trusted global source of essential and advanced chemicals, empowering scientists and researchers to drive progress in science and industry.

Contact

Address: 3281 E Guasti Rd
Ontario, CA 91761, United States
Phone: (601) 213-4426
Email: info@benchchem.com

[Contact our Ph.D. Support Team for a compatibility check](#)

