

# HPLC method development for purity analysis of Octahydrofuro[3,4-c]pyridine

**Author:** BenchChem Technical Support Team. **Date:** April 2026

## Compound of Interest

Compound Name: *Octahydrofuro[3,4-c]pyridine hydrochloride*  
Cat. No.: *B11783676*

[Get Quote](#)

As a Senior Application Scientist, developing a robust purity assay for Octahydrofuro[3,4-c]pyridine (CAS 933688-11-0) requires navigating a classic analytical bottleneck: the complete absence of a conjugated pi-electron system. Because this bicyclic aliphatic amine lacks a functional UV chromophore, traditional Reversed-Phase HPLC with UV detection (RP-HPLC-UV) is fundamentally inadequate<sup>[1]</sup>.

This guide objectively compares the two most viable analytical pathways for this compound: Pre-column Derivatization with UV Detection versus Direct Native Analysis using Hydrophilic Interaction Liquid Chromatography coupled with Charged Aerosol Detection (HILIC-CAD).

## The Mechanistic Challenge: Why Traditional RP-HPLC Fails

For aliphatic amines, analysts often attempt low-wavelength UV detection (e.g., 210 nm). However, this approach is plagued by severe baseline drift during gradient elution and high background noise from mobile phase absorbance<sup>[2]</sup>. Furthermore, highly polar amines like Octahydrofuro[3,4-c]pyridine suffer from poor retention and severe peak tailing on traditional

C18 columns. This is caused by secondary electrostatic interactions between the protonated secondary amine (pKa ~9.5) and residual silanols on the silica support[1].

To retain such polar amines in standard RP-HPLC, non-volatile ion-pairing reagents (like sodium octanesulfonate) are required. However, these reagents are strictly incompatible with modern universal detectors (like CAD or MS) because they cause massive background noise and ion suppression[3]. Therefore, we must pivot to alternative strategies.

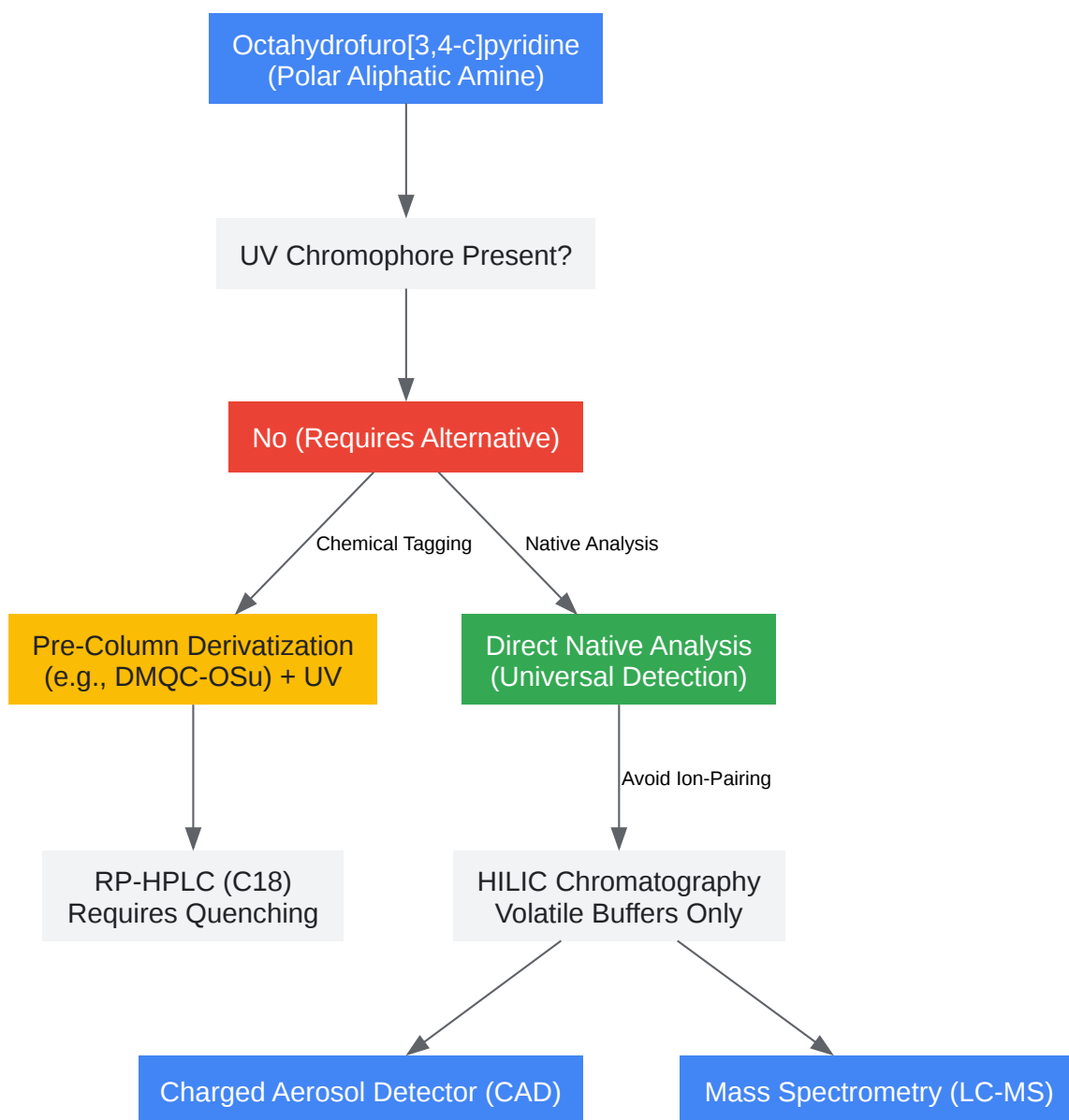

[Click to download full resolution via product page](#)

Workflow for selecting the optimal analytical strategy for non-chromophoric aliphatic amines.

## Methodological Comparison: Derivatization vs. Universal Detection

### Approach A: Pre-Column Derivatization (RP-HPLC-UV)

Aliphatic amines can be quantitatively converted into UV-active or fluorescent derivatives using reagents like 2,6-dimethyl-4-quinolinecarboxylic acid N-hydroxysuccinimide ester (DMQC-OSu) [4].

- **The Causality:** The N-hydroxysuccinimide ester reacts selectively with the secondary amine of Octahydrofuro[3,4-c]pyridine under mildly basic conditions, attaching a large conjugated quinoline ring. This allows the molecule to be retained on a standard C18 column and detected at 316 nm.
- **The Drawback:** Derivatization introduces reaction yield variability. More critically for purity analysis, if an unknown process impurity lacks an amine group (e.g., a hydroxyl-containing byproduct), it will not react with the tag and will remain "invisible" to the UV detector, compromising the assay's trustworthiness[3].

### Approach B: Direct Analysis via HILIC-CAD

Charged Aerosol Detection (CAD) is a near-universal detector that measures the charge transferred to residual non-volatile particles after the mobile phase is evaporated[5]. Because Octahydrofuro[3,4-c]pyridine is a non-volatile salt form, it is an ideal candidate for CAD[2].

- **The Causality:** By pairing CAD with HILIC, we eliminate the need for ion-pairing reagents. HILIC utilizes a polar stationary phase (e.g., BEH Amide) and an acetonitrile-rich mobile phase. At pH 3.0, the amine is fully protonated and partitions strongly into the immobilized water layer on the stationary phase. Volatile buffers (ammonium formate) elute the compound cleanly and evaporate completely in the CAD drift tube, leaving only the analyte particles to be charged and detected[3].

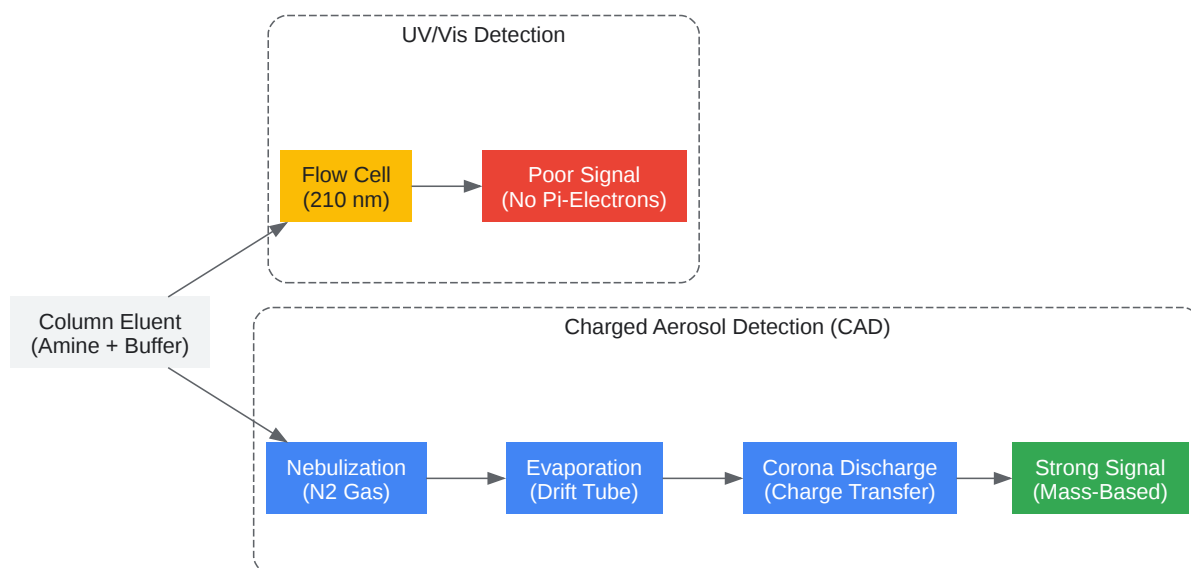

[Click to download full resolution via product page](#)

Mechanistic comparison of UV vs. CAD detection for molecules lacking a chromophore.

## Self-Validating Experimental Protocols

To ensure absolute trustworthiness, the following protocols are designed as self-validating systems, incorporating internal System Suitability Testing (SST) logic.

### Protocol 1: Direct Native Analysis (HILIC-CAD) - Recommended

System Setup:

- Column: Waters Acquity UPLC BEH Amide (100 × 2.1 mm, 1.7 μm).

- Mobile Phase A: 10 mM Ammonium Formate in Water, pH adjusted to 3.0 with Formic Acid. (Must be filtered through 0.2  $\mu$ m PTFE to prevent CAD capillary blockage).
- Mobile Phase B: 0.1% Formic Acid in Acetonitrile.
- Gradient: 95% B to 60% B over 10 minutes. Flow rate: 0.4 mL/min.
- Detector Settings: CAD Evaporation Temperature: 35°C; Data Collection Rate: 10 Hz; Filter: 3.6s.

#### Self-Validating Workflow:

- Step 1: Equilibration. Pump 95% B for at least 20 column volumes. HILIC requires extended equilibration to establish the stable aqueous layer on the silica surface.
- Step 2: SST Injection. Inject 6 replicates of a 0.1% (w/w) Octahydrofuro[3,4-c]pyridine standard.
- Step 3: Validation Logic. The system is only valid if the Signal-to-Noise (S/N) ratio is >10, and the peak area Relative Standard Deviation (RSD) is <5.0%. (Note: CAD inherently has higher variance than UV).
- Step 4: Data Processing. Because CAD response is non-linear (mass-flow dependent), apply a power function transformation ( $y = ax^b$ ), where  $y$  is the peak area and  $x$  is the concentration, to linearize the calibration curve for accurate impurity quantification[2].

## Protocol 2: Pre-Column Derivatization (RP-HPLC-UV)

#### Reaction Setup:

- Reagent: Prepare 10 mM DMQC-OSu in Acetonitrile[4].
- Buffer: 0.1 M Sodium Borate buffer, pH 9.0.
- Reaction: Mix 100  $\mu$ L sample (in water), 100  $\mu$ L buffer, and 200  $\mu$ L reagent. Incubate at 60°C for 30 minutes.

- Quenching: Add 50  $\mu$ L of 0.1 M HCl to stop the reaction and stabilize the derivative.

#### System Setup & Validation:

- Column: C18 (150  $\times$  4.6 mm, 3  $\mu$ m).
- Mobile Phase: Water / Acetonitrile gradient.
- Detection: UV at 316 nm.
- SST Logic: Inject a reagent blank. The system is only valid if the resolution ( ) between the derivatized Octahydrofuro[3,4-c]pyridine peak and the hydrolyzed reagent peak is > 2.0.

## Quantitative Performance Comparison

The following table summarizes the expected performance metrics based on the physiochemical behavior of aliphatic amines under both methodologies.

Performance Metric	HILIC-CAD (Direct Native)	RP-HPLC-UV (Derivatized)	Causality / Rationale
Sample Preparation	Simple (Dilute & Shoot in 80% ACN)	Complex (Incubation & Quenching)	CAD directly detects the native mass; UV requires chemical tagging.
Universal Impurity Detection	High	Low	CAD detects any non-volatile impurity[5]. UV only detects impurities that successfully react with the tag.
Sensitivity (LOQ)	~5 - 10 ng on-column	~1 - 5 ng on-column	Derivatization yields highly absorptive chromophores, edging out CAD in absolute baseline sensitivity.
Linearity	Non-linear (Power function required)	Linear ( )	CAD droplet charging efficiency varies with particle size[2].
Robustness	High (Fewer handling steps)	Moderate	Derivatization is susceptible to matrix effects and incomplete reaction yields[3].

Conclusion: For the purity analysis of Octahydrofuro[3,4-c]pyridine in a regulated drug development environment, HILIC-CAD is the superior choice. It eliminates the blind spots inherent to derivatization, ensuring that all non-volatile process impurities and degradants are accurately detected and quantified, thereby upholding the highest standards of scientific integrity.

## References

1. octahydrofuro[3,4-c]pyridine | 933688-11-0 - Sigma-Aldrich. 2.[1] Analytical Methodology for Characterization of Reactive Starting Materials and Intermediates Commonly Used in the

Synthesis of Small Molecule Pharmaceuticals - American Pharmaceutical Review. [1](#) [3](#).[\[2\]](#)  
Charged Aerosol Detection in Pharmaceutical Analysis: An Overview - LCGC International.[2](#) [4](#).  
[\[4\]](#) Derivatization and Separation of Aliphatic Amines - MilliporeSigma. [4](#) [5](#).[\[3\]](#) Evaluating LC methods for enhanced charged aerosol detector response: a case study using underivatized amino acids - LCMS.cz. [3](#) [6](#).[\[5\]](#) Episode 1: The Benefits of Charged Aerosol Detection (CAD) in High-Performance Liquid Chromatography (HPLC) - Thermo Fisher Scientific. [5](#)

### Need Custom Synthesis?

BenchChem offers custom synthesis for rare earth carbides and specific isotopic labeling.

Email: [info@benchchem.com](mailto:info@benchchem.com) or [Request Quote Online](#).

## Sources

- [1. americanpharmaceuticalreview.com](http://americanpharmaceuticalreview.com) [[americanpharmaceuticalreview.com](http://americanpharmaceuticalreview.com)]
- [2. chromatographyonline.com](http://chromatographyonline.com) [[chromatographyonline.com](http://chromatographyonline.com)]
- [3. lcms.cz](http://lcms.cz) [[lcms.cz](http://lcms.cz)]
- [4. Derivatization and Separation of Aliphatic Amines](#) [[sigmaaldrich.com](http://sigmaaldrich.com)]
- [5. Episode 1: The Benefits of Charged Aerosol Detection \(CAD\) in High-Performance Liquid Chromatography \(HPLC\) - AnalyteGuru](#) [[thermofisher.com](http://thermofisher.com)]
- To cite this document: BenchChem. [HPLC method development for purity analysis of Octahydrofuro[3,4-c]pyridine]. BenchChem, [2026]. [Online PDF]. Available at: [<https://www.benchchem.com/product/b11783676/docs#hplc-method-development-for-purity-analysis-of-octahydrofuro-3-4-c-pyridine>]

---

### Disclaimer & Data Validity:

The information provided in this document is for Research Use Only (RUO) and is strictly not intended for diagnostic or therapeutic procedures. While BenchChem strives to provide accurate protocols, we make no warranties, express or implied, regarding the fitness of this product for every specific experimental setup.

**Technical Support:** The protocols provided are for reference purposes. Unsure if this reagent suits your experiment?

**Need Industrial/Bulk Grade?** [Request Custom Synthesis Quote](#)

## BenchChem

Our mission is to be the trusted global source of essential and advanced chemicals, empowering scientists and researchers to drive progress in science and industry.

### Contact

Address: 3281 E Guasti Rd  
Ontario, CA 91761, United States  
Phone: (601) 213-4426  
Email: [info@benchchem.com](mailto:info@benchchem.com)

[Contact our Ph.D. Support Team for a compatibility check](#)