

# Technical Support Center: Trefoil Factor 3 (TFF3) Sample Integrity

**Author:** BenchChem Technical Support Team. **Date:** April 2026

## Compound of Interest

Compound Name: *ITF 300*  
CAS No.: *129480-74-6*  
Cat. No.: *B1178138*

[Get Quote](#)

This technical support center provides researchers, scientists, and drug development professionals with guidance on preventing the degradation of Trefoil Factor 3 (TFF3) in experimental samples. Find answers to frequently asked questions and troubleshooting advice to ensure the accuracy and reliability of your results.

## Frequently Asked Questions (FAQs)

Q1: What are the primary causes of TFF3 degradation in biological samples?

A1: TFF3 degradation is primarily caused by enzymatic activity. TFF3 is susceptible to enzymatic truncation at both its N- and C-termini, particularly in environments rich in proteases such as the gastrointestinal tract.[1][2] Studies have shown that monomeric forms of TFF3 are degraded more rapidly than their homodimeric counterparts.[3][4][5] Sample handling, storage conditions, and the presence of certain chemicals can also contribute to its degradation.

Q2: How can I minimize TFF3 degradation during sample collection and handling?

A2: To minimize TFF3 degradation, it is crucial to follow proper sample collection and handling protocols. For blood samples, it is recommended to use a serum separator tube and allow the

blood to clot for two hours at room temperature or overnight at 4°C before centrifugation.[6][7] Plasma should be collected using EDTA or heparin as an anticoagulant and centrifuged within 30 minutes of collection.[6][7][8] For all sample types, it is advisable to work quickly and keep the samples on ice to reduce enzymatic activity. The addition of a protease inhibitor cocktail to your samples immediately after collection is also a recommended practice.[9]

Q3: What are the optimal storage conditions for samples containing TFF3?

A3: For short-term storage (up to 5 days), samples can be kept at 4°C.[6][7] For long-term storage, it is recommended to aliquot the samples and store them at -20°C (for up to 1 month) or -80°C (for up to 2 months).[6][7] It is critical to avoid repeated freeze-thaw cycles as this can lead to significant degradation of TFF3.[6][7][8]

## Troubleshooting Guide

Issue	Potential Cause	Recommended Solution
Low or undetectable TFF3 levels in samples	Sample Degradation: TFF3 has been degraded due to improper handling or storage.	Review and strictly adhere to recommended sample collection and storage protocols. Ensure samples are processed quickly and stored at the correct temperature. Add a protease inhibitor cocktail immediately after collection.[9]
Monomeric TFF3 Degradation: The monomeric form of TFF3 is less stable and degrades more rapidly than the homodimer.[3][4]	Consider experimental conditions that may favor the dimeric form. Note that some commercial assays may detect both forms.	
Inconsistent results between sample aliquots	Repeated Freeze-Thaw Cycles: Aliquots have been subjected to multiple freeze-thaw cycles, leading to variable degradation.	Prepare single-use aliquots to avoid the need for repeated freezing and thawing of the same sample.[6][7][8]
Inadequate Mixing: If using protease inhibitors, they may not have been adequately mixed throughout the sample.	Gently vortex or invert the sample tube after adding any inhibitors or solutions to ensure even distribution.	
Discrepancy between expected and measured TFF3 concentrations	Gastrointestinal Protease Activity: Samples from the gastrointestinal tract are particularly prone to rapid TFF3 degradation.	Work with samples on ice and add protease inhibitors immediately. Be aware that a stable metabolite, TFF3(7-54), may be present and could be detected depending on the assay used.[1][2]

## Quantitative Data on TFF3 Stability

The stability of TFF3 and its variants can vary significantly depending on the environment. The following table summarizes the half-life of different TFF3 forms under specific conditions.

TFF3 Form	Condition	Half-life (t <sub>1/2</sub> )	Reference
TFF3 (monomer)	Gastric Environment	< 5 minutes	[1][2]
TFF3 (homodimer)	Gastric Environment	~ 40 minutes	[1][2]
TFF3 (monomer)	Intestinal Environment	< 5 minutes	[1][2]
TFF3(10-50) (trefoil domain)	Intestinal Environment	< 30 minutes	[1][2]
TFF3(7-54) (stable metabolite)	Simulated Gastric & Intestinal Fluid (SGF & SIF)	> 24 hours	[1][2]
Wild-type TFF3	In MDA-MB-231 cells	5.3 hours	[3][4]
TFF3-C57F (monomeric mutant)	In MDA-MB-231 cells	1.6 hours	[3][4]

## Experimental Protocols

### Protocol 1: Serum and Plasma Collection

- Serum Collection:
  - Collect whole blood in a serum separator tube.
  - Allow the blood to clot for 2 hours at room temperature or overnight at 4°C.
  - Centrifuge at 1000 x g for 20 minutes.
  - Carefully collect the serum supernatant.
  - Assay immediately or aliquot and store at -20°C or -80°C. Avoid repeated freeze-thaw cycles.[6][7]
- Plasma Collection:

- Collect whole blood into a tube containing EDTA or heparin as an anticoagulant.
- Centrifuge at 1000 x g at 2-8°C for 15 minutes within 30 minutes of collection.
- Carefully collect the plasma supernatant.
- Assay immediately or aliquot and store at -20°C or -80°C. Avoid repeated freeze-thaw cycles.[6][7][8]

## Protocol 2: Tissue Homogenate Preparation

- Rinse tissues with ice-cold PBS to remove excess blood.
- Weigh the tissue before homogenization.
- Mince the tissue into small pieces and homogenize in a suitable lysis buffer (e.g., PBS with protease inhibitors) on ice using a glass homogenizer. A common ratio is 1:9 (w:v), for example, 900 µL of lysis buffer for 100 mg of tissue.[6]
- For cellular disruption, sonicate the suspension with an ultrasonic cell disrupter until the solution is clear.
- Centrifuge the homogenate at 10,000 x g for 5 minutes to pellet cellular debris.
- Collect the supernatant for immediate assay or aliquot and store at ≤-20°C.[6]

## Visualizations

### TFF3 Signaling Pathways

TFF3 is known to be involved in several signaling pathways that promote cell migration and survival. The diagram below illustrates some of the key pathways activated by TFF3.

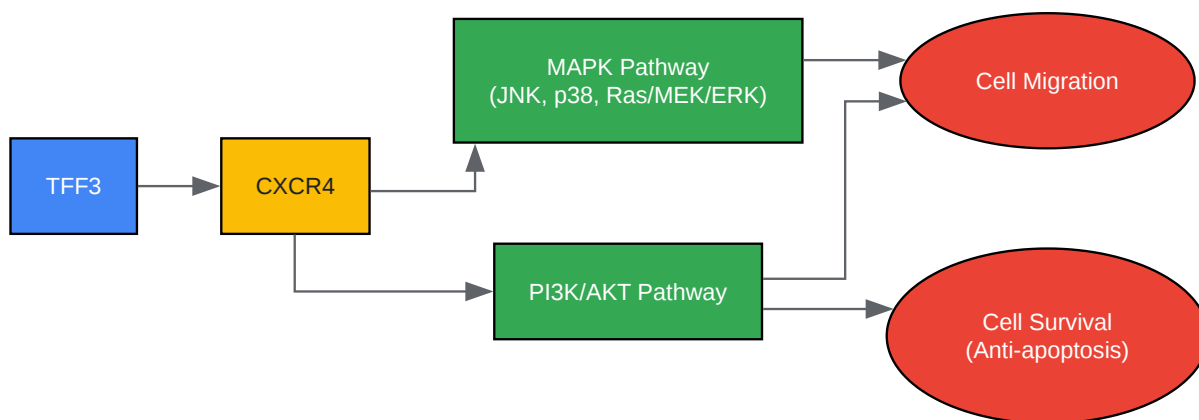

[Click to download full resolution via product page](#)

Caption: TFF3 signaling pathways involved in cell migration and survival.

## Troubleshooting Workflow for TFF3 Degradation

This workflow provides a logical sequence of steps to diagnose and resolve issues related to TFF3 degradation in your samples.

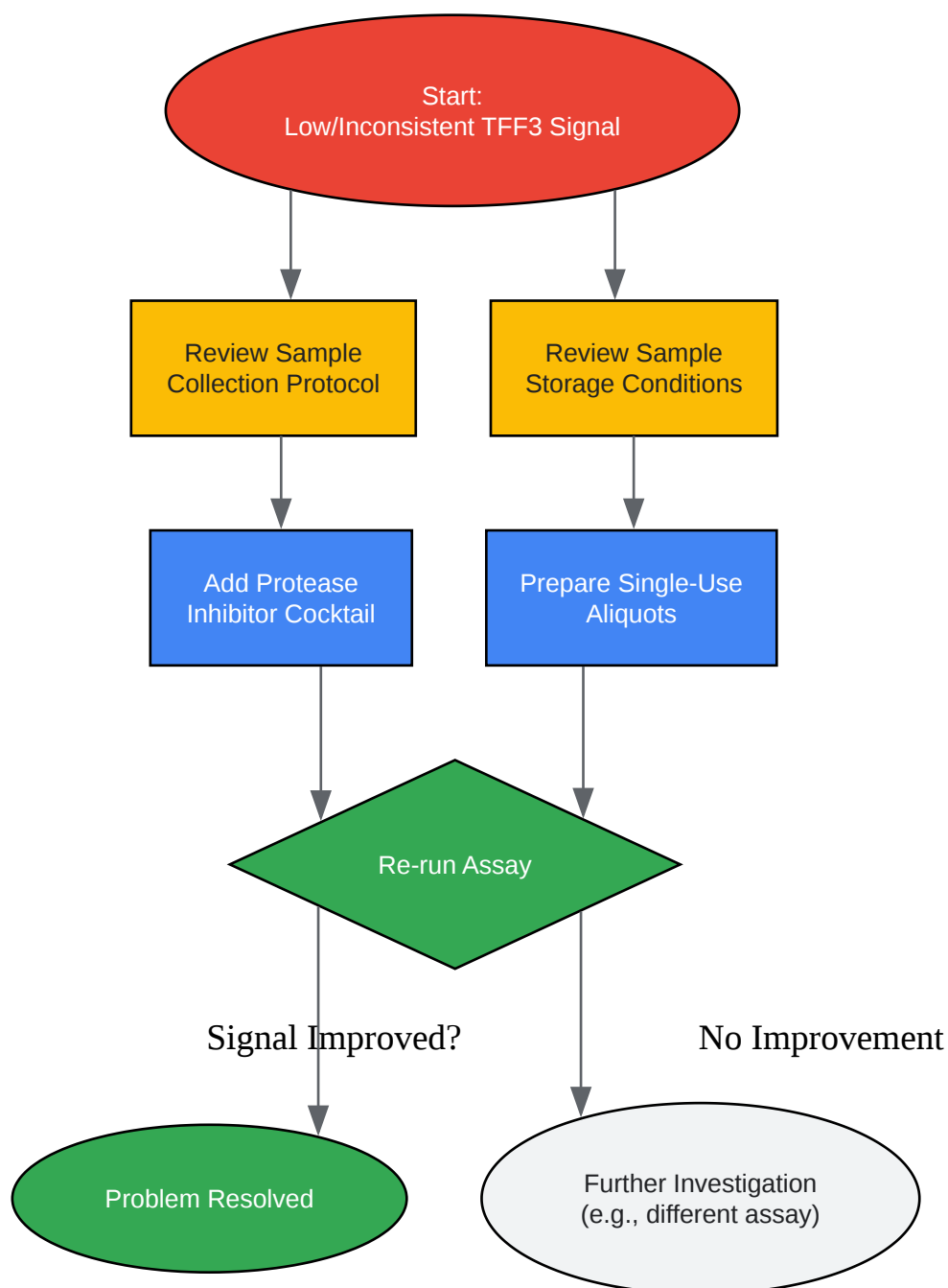

[Click to download full resolution via product page](#)

Caption: A troubleshooting workflow for addressing TFF3 degradation issues.

### Need Custom Synthesis?

BenchChem offers custom synthesis for rare earth carbides and specific isotopic labeling.

Email: [info@benchchem.com](mailto:info@benchchem.com) or [Request Quote Online](#).

## References

- [1. Chemical Synthesis of TFF3 Reveals Novel Mechanistic Insights and a Gut-Stable Metabolite - PMC \[pmc.ncbi.nlm.nih.gov\]](#)
- [2. pubs.acs.org \[pubs.acs.org\]](#)
- [3. pubs.acs.org \[pubs.acs.org\]](#)
- [4. Monomerization of Homodimeric Trefoil Factor 3 \(TFF3\) by an Aminonitrile Compound Inhibits TFF3-Dependent Cancer Cell Survival - PMC \[pmc.ncbi.nlm.nih.gov\]](#)
- [5. Pathological and therapeutic roles of bioactive peptide trefoil factor 3 in diverse diseases: recent progress and perspective - PMC \[pmc.ncbi.nlm.nih.gov\]](#)
- [6. immunomart.com \[immunomart.com\]](#)
- [7. afgsci.com \[afgsci.com\]](#)
- [8. img.abclonal.com \[img.abclonal.com\]](#)
- [9. Trefoil Factor 3 \(TFF3\) Is Involved in Cell Migration for Skeletal Repair - PMC \[pmc.ncbi.nlm.nih.gov\]](#)
- To cite this document: BenchChem. [Technical Support Center: Trefoil Factor 3 (TFF3) Sample Integrity]. BenchChem, [2026]. [Online PDF]. Available at: [\[https://www.benchchem.com/product/b1178138/docs#technical-support-center-trefoil-factor-3-tff3-sample-integrity\]](https://www.benchchem.com/product/b1178138/docs#technical-support-center-trefoil-factor-3-tff3-sample-integrity)

---

### Disclaimer & Data Validity:

The information provided in this document is for Research Use Only (RUO) and is strictly not intended for diagnostic or therapeutic procedures. While BenchChem strives to provide accurate protocols, we make no warranties, express or implied, regarding the fitness of this product for every specific experimental setup.

**Technical Support:** The protocols provided are for reference purposes. Unsure if this reagent suits your experiment?

**Need Industrial/Bulk Grade?** [Request Custom Synthesis Quote](#)

# BenchChem

Our mission is to be the trusted global source of essential and advanced chemicals, empowering scientists and researchers to drive progress in science and industry.

## Contact

Address: 3281 E Guasti Rd

Ontario, CA 91761, United States

Phone: (601) 213-4426

Email: [info@benchchem.com](mailto:info@benchchem.com)

[Contact our Ph.D. Support Team for a compatibility check](#)