

Application Notes and Protocols for Quantitative PCR of Human CXCL5 mRNA

Author: BenchChem Technical Support Team. **Date:** April 2026

Compound of Interest

Compound Name:	ENA-78
CAS No.:	136956-40-6
Cat. No.:	B1178700

[Get Quote](#)

These application notes provide a comprehensive guide for researchers, scientists, and drug development professionals on the quantification of human CXCL5 mRNA using quantitative real-time PCR (qPCR). This document includes validated primer sets, detailed experimental protocols, and data presentation guidelines.

Introduction

Chemokine (C-X-C motif) ligand 5 (CXCL5) is a small cytokine belonging to the CXC chemokine family, also known as epithelial-derived neutrophil-activating peptide 78 (**ENA-78**). It plays a crucial role in inflammation by recruiting and activating neutrophils.[1] CXCL5 exerts its effects by binding to the C-X-C motif chemokine receptor 2 (CXCR2).[2] Dysregulation of CXCL5 expression is implicated in various inflammatory diseases and cancers, making it a significant target for research and therapeutic development.[3] Accurate quantification of CXCL5 mRNA is essential for understanding its biological roles and for the development of novel therapeutics.

Quantitative PCR Primers for Human CXCL5 mRNA

The selection of highly specific and efficient primers is critical for successful qPCR analysis. Below are validated primer sets for the quantification of human CXCL5 mRNA.

Table 1: Validated qPCR Primers for Human CXCL5 mRNA

Target Gene	Primer Sequence (5' -> 3')	Source
Human CXCL5	Forward: CAGACCACGCAAGGAGTTC	OriGene Technologies[4]
	ATC Reverse: TTCCTTCCCGTTCTTCAGGG AG	
Human CXCL5	Forward: GTTCCATCTCGCCATTCATG	Published Research[5]
	C Reverse: GCGGCTATGACTGAGGAAG G	
Human GAPDH (Reference Gene)	Forward: ATGGATGACGATATCGCTC	Published Research[5]
	Reverse: GATTCCATACCCAGGAAGG	

Note: It is highly recommended to validate the primer efficiency and specificity in your specific experimental setup.

CXCL5 Signaling Pathway

CXCL5 primarily signals through its receptor CXCR2, a G-protein coupled receptor. This interaction activates multiple downstream signaling cascades, including the PI3K/AKT, MAPK (ERK, JNK, p38), and STAT3 pathways.[2][3][6] These pathways regulate cellular processes such as proliferation, migration, and survival.

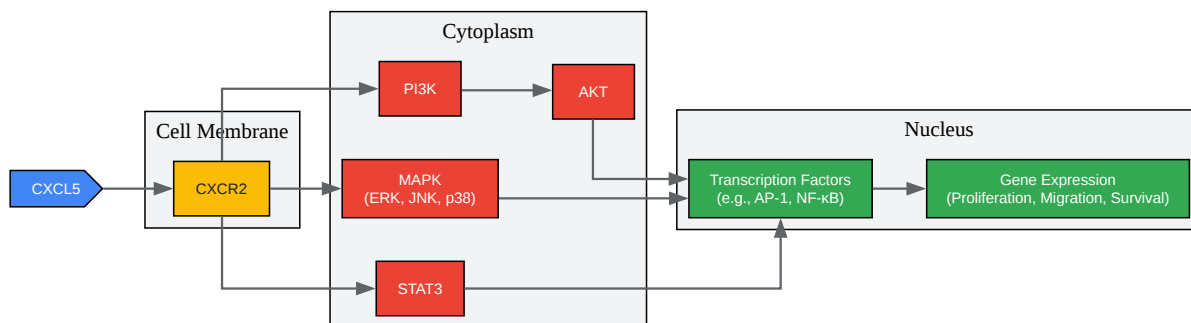

[Click to download full resolution via product page](#)

Caption: CXCL5 signaling pathway initiated by binding to CXCR2.

Experimental Workflow for CXCL5 mRNA Quantification

The overall workflow for quantifying CXCL5 mRNA involves several key steps, from sample preparation to data analysis.

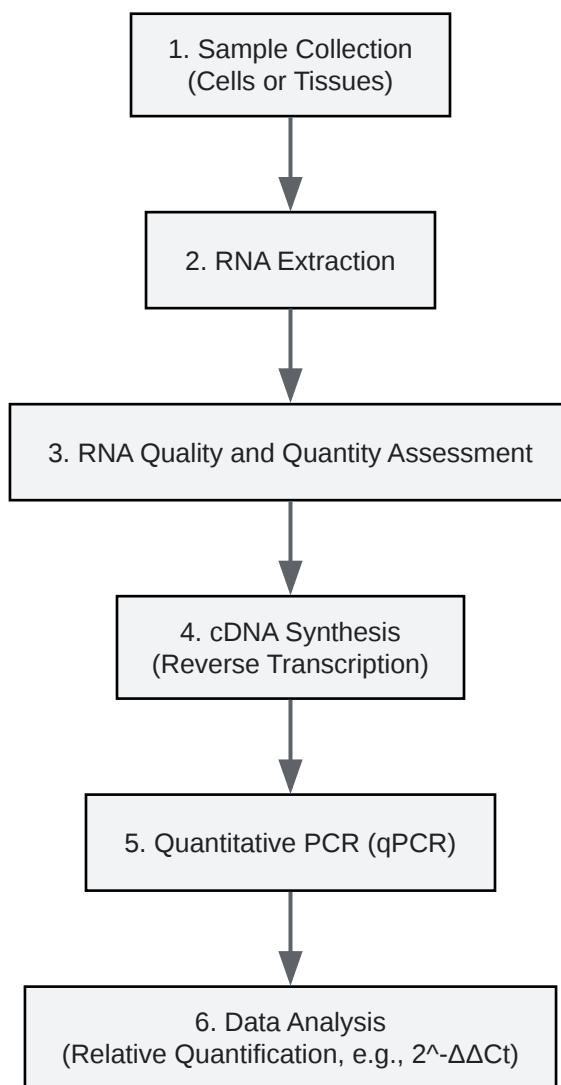

[Click to download full resolution via product page](#)

Caption: Experimental workflow for qPCR-based mRNA quantification.

Detailed Experimental Protocol

This protocol is designed for SYBR Green-based qPCR, a common method for gene expression analysis.

RNA Extraction

- Isolate total RNA from cell or tissue samples using a TRIzol-based method or a commercial RNA purification kit according to the manufacturer's instructions.

- To avoid genomic DNA contamination, treat the extracted RNA with DNase I.

RNA Quality and Quantity Assessment

- Determine the concentration and purity of the RNA using a spectrophotometer (e.g., NanoDrop). An A260/A280 ratio of 1.8-2.0 is considered pure.
- Assess RNA integrity by agarose gel electrophoresis or a bioanalyzer. Intact 28S and 18S ribosomal RNA bands should be visible.

cDNA Synthesis (Reverse Transcription)

- Synthesize first-strand cDNA from 1-2 µg of total RNA using a reverse transcription kit with oligo(dT) or random hexamer primers.
- Follow the manufacturer's protocol for the reverse transcription reaction.
- A typical reaction mixture includes RNA template, reverse transcriptase, dNTPs, RNase inhibitor, and reaction buffer.
- Incubate the reaction at the recommended temperature and time (e.g., 42°C for 60 minutes), followed by enzyme inactivation (e.g., 70°C for 10 minutes).

Quantitative PCR (qPCR)

- Prepare the qPCR reaction mix in a 96-well optical plate. A typical 20 µL reaction is outlined in Table 2.
- Include no-template controls (NTCs) to check for contamination and no-reverse-transcriptase controls (-RT) to check for genomic DNA contamination.
- Run all samples and controls in triplicate.

Table 2: qPCR Reaction Mixture

Component	Volume (μL)	Final Concentration
2x SYBR Green Master Mix	10	1x
Forward Primer (10 μM)	0.5	250 nM
Reverse Primer (10 μM)	0.5	250 nM
cDNA Template (diluted)	2	1-100 ng
Nuclease-free Water	7	-
Total Volume	20	

- Perform qPCR using a real-time PCR detection system with the thermal cycling conditions described in Table 3.

Table 3: qPCR Thermal Cycling Conditions

Stage	Step	Temperature (°C)	Time	Cycles
1	Initial Denaturation	95	10 min	1
2	Denaturation	95	15 sec	40
	Annealing/Extension	60	60 sec	
3	Melt Curve Analysis	60-95	(instrument default)	1

Data Analysis

- Analyze the qPCR data using the comparative Ct ($\Delta\Delta C_t$) method for relative quantification of CXCL5 mRNA expression.
- Step 1: Normalization to Reference Gene: Calculate the ΔC_t for each sample by subtracting the C_t value of the reference gene (e.g., GAPDH) from the C_t value of the target gene

(CXCL5).

- $\Delta Ct = Ct(CXCL5) - Ct(GAPDH)$
- Step 2: Normalization to Control Group: Calculate the $\Delta\Delta Ct$ by subtracting the average ΔCt of the control group from the ΔCt of each experimental sample.
 - $\Delta\Delta Ct = \Delta Ct(sample) - \Delta Ct(control)$
- Step 3: Calculate Fold Change: Determine the fold change in gene expression using the formula $2^{-\Delta\Delta Ct}$.

Data Presentation

Summarize the quantitative data in a clear and structured format. An example is provided in Table 4.

Table 4: Relative Quantification of CXCL5 mRNA Expression

Sample Group	Average Ct (CXCL5)	Average Ct (GAPDH)	Average ΔCt	Average $\Delta\Delta Ct$	Fold Change ($2^{-\Delta\Delta Ct}$)
Control	24.5	18.2	6.3	0	1.0
Treatment 1	22.1	18.3	3.8	-2.5	5.7
Treatment 2	26.8	18.1	8.7	2.4	0.2

Conclusion

This document provides a comprehensive guide for the quantitative analysis of human CXCL5 mRNA using qPCR. Adherence to these protocols and guidelines will enable researchers to obtain reliable and reproducible data, facilitating a deeper understanding of the role of CXCL5 in health and disease.

Need Custom Synthesis?

BenchChem offers custom synthesis for rare earth carbides and specific isotopic labeling.

Email: info@benchchem.com or [Request Quote Online](#).

References

- [1. CXCL5 signaling is a shared pathway of neuroinflammation and blood–brain barrier injury contributing to white matter injury in the immature brain - PMC \[pmc.ncbi.nlm.nih.gov\]](#)
- [2. Activation of CXCL5-CXCR2 axis promotes proliferation and accelerates G1 to S phase transition of papillary thyroid carcinoma cells and activates JNK and p38 pathways - PMC \[pmc.ncbi.nlm.nih.gov\]](#)
- [3. Frontiers | CXCL5: A coachman to drive cancer progression \[frontiersin.org\]](#)
- [4. origene.com \[origene.com\]](#)
- [5. Role of CXCL5 in Regulating Chemotaxis of Innate and Adaptive Leukocytes in Infected Lungs Upon Pulmonary Influenza Infection - PMC \[pmc.ncbi.nlm.nih.gov\]](#)
- [6. researchgate.net \[researchgate.net\]](#)
- To cite this document: BenchChem. [Application Notes and Protocols for Quantitative PCR of Human CXCL5 mRNA]. BenchChem, [2026]. [Online PDF]. Available at: [\[https://www.benchchem.com/product/b1178700/docs#application-notes-and-protocols-for-quantitative-pcr-of-human-cxcl5-mrna\]](https://www.benchchem.com/product/b1178700/docs#application-notes-and-protocols-for-quantitative-pcr-of-human-cxcl5-mrna)

Disclaimer & Data Validity:

The information provided in this document is for Research Use Only (RUO) and is strictly not intended for diagnostic or therapeutic procedures. While BenchChem strives to provide accurate protocols, we make no warranties, express or implied, regarding the fitness of this product for every specific experimental setup.

Technical Support: The protocols provided are for reference purposes. Unsure if this reagent suits your experiment?

Need Industrial/Bulk Grade? [Request Custom Synthesis Quote](#)

BenchChem

Our mission is to be the trusted global source of essential and advanced chemicals, empowering scientists and researchers to drive progress in science and industry.

Contact

Address: 3281 E Guasti Rd

Ontario, CA 91761, United States

Phone: (601) 213-4426

Email: info@benchchem.com

[Contact our Ph.D. Support Team for a compatibility check](#)