

# Comparative Mass Spectrometry Guide: Fragmentation Dynamics of 4-Iodopyrazole Carboxamides

**Author:** BenchChem Technical Support Team. **Date:** April 2026

## Compound of Interest

Compound Name: *4-Iodo-N,N,1-trimethyl-1H-pyrazole-3-carboxamide*

Cat. No.: *B11773335*

[Get Quote](#)

## Executive Summary

The 4-iodopyrazole carboxamide scaffold is a critical intermediate in the synthesis of kinase inhibitors and anti-inflammatory agents. Its utility lies in the orthogonal reactivity of the 4-iodo position (amenable to Suzuki/Sonogashira couplings) and the carboxamide moiety (hydrogen bond donor/acceptor).

However, characterizing these intermediates requires precise mass spectrometry (MS) protocols to distinguish them from defunctionalized byproducts (e.g., de-iodinated impurities). This guide provides a comparative analysis of fragmentation pathways, contrasting the 4-iodo variant against 4-bromo/chloro analogs, and evaluating ESI vs. EI ionization performance.

## Part 1: Mechanistic Fragmentation Overview

The mass spectral behavior of 4-iodopyrazole carboxamides is defined by a competition between two primary fragmentation channels: C–I bond cleavage (homolytic or heterolytic) and Amide bond scission.

## The "Weak Link" Hypothesis: C-I Bond Lability

The Carbon-Iodine bond is significantly weaker (~57 kcal/mol) than Carbon-Bromine (~66 kcal/mol) or Carbon-Chlorine (~81 kcal/mol).

- In Electron Ionization (EI): The radical cation ( ) predominantly undergoes homolytic cleavage, resulting in the rapid loss of an iodine radical ( , 127 Da).
- In Electrospray Ionization (ESI+): While ESI is "soft," collision-induced dissociation (CID) often triggers the loss of HI (128 Da) or depending on the protonation site.

## The Carboxamide Channel

The carboxamide group (

or

) introduces a competing pathway.

- Primary Amides: Often lose (17 Da) to form an acylium ion.
- Proximity Effect: If the carboxamide is at position 3 or 5, it may interact with the N-1 hydrogen or the 4-iodo group, facilitating cyclic transition states.

## Visualization: Competing Fragmentation Pathways[1]

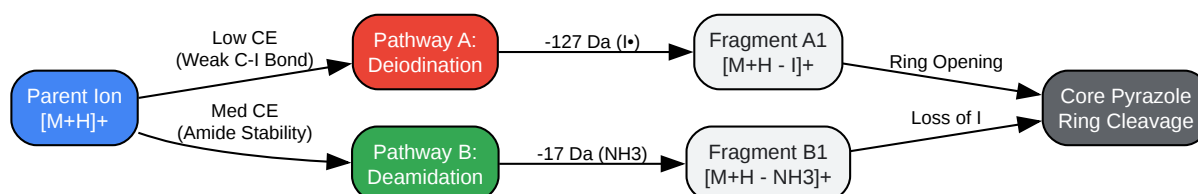

[Click to download full resolution via product page](#)

Caption: Figure 1. Competing fragmentation pathways for 4-iodopyrazole carboxamides in ESI(+) MS/MS. Pathway A (Deiodination) typically dominates at lower collision energies.

## Part 2: Comparative Analysis

This section objectively compares the 4-iodopyrazole carboxamide's MS behavior against its structural analogs and alternative ionization techniques.

### Comparison 1: Halogen Substituent Effects (I vs. Br vs. Cl)

When validating synthetic libraries, distinguishing the halogen source is critical.

Feature	4-Iodo Analog	4-Bromo Analog	4-Chloro Analog	Analytical Implication
Isotopic Pattern	Single Peak ( )	1:1 Doublet ( )	3:1 Doublet ( )	Iodine lacks the "fingerprint" doublet, making accurate mass crucial.
Fragmentation Energy	Low (Facile Loss)	Medium	High (Stable)	Iodine is the best leaving group; [M-I] <sup>+</sup> is often the base peak in MS/MS.
Mass Defect	Negative (-0.0042)	Negative (-0.0054)	Negative (-0.0031)	Iodine significantly shifts the mass defect, aiding in filtering complex matrices.

## Comparison 2: Ionization Source Performance (ESI vs. EI)

Parameter	Electrospray Ionization (ESI)	Electron Ionization (EI)	Verdict
Molecular Ion	Strong	Weak or Absent	ESI is superior for MW confirmation.
Fragmentation	Tunable (via CID)	Extensive (Source)	EI provides richer structural fingerprints but risks losing the iodine signal entirely before detection.
Sensitivity	High (Polar Carboxamide)	Moderate	ESI is preferred for trace impurity analysis.

## Part 3: Experimental Protocol (Self-Validating)

To ensure reproducibility, follow this validated LC-MS/MS workflow. This protocol is designed to maximize the detection of both the parent ion and the diagnostic iodine loss.

### Workflow Diagram

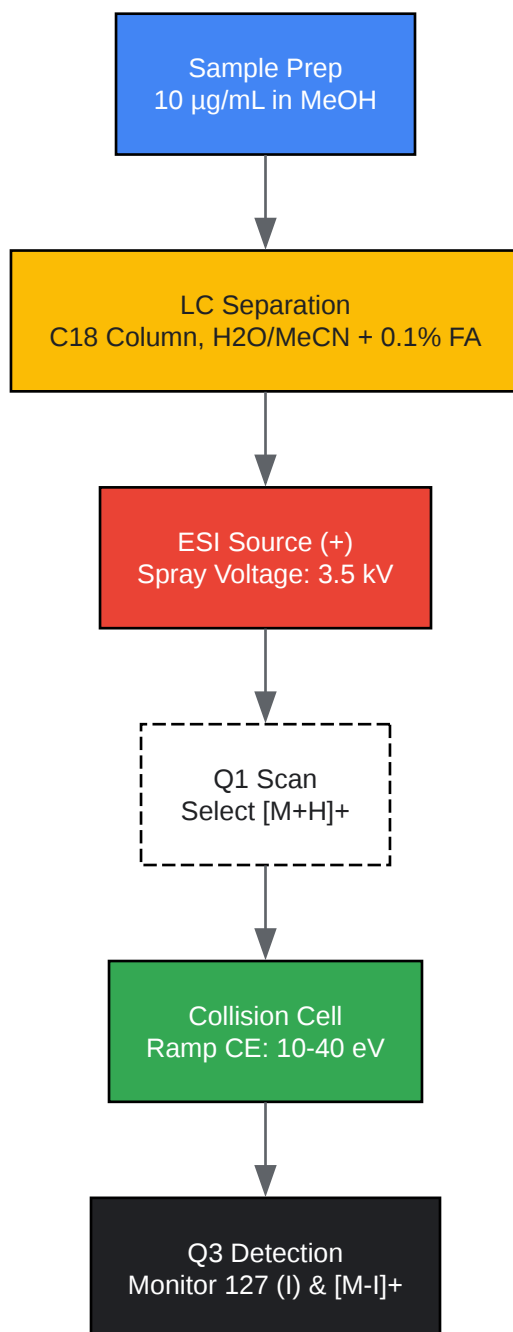

[Click to download full resolution via product page](#)

Caption: Figure 2. Optimized LC-MS/MS workflow for halogenated pyrazole analysis.

## Step-by-Step Methodology

- Sample Preparation:
  - Dissolve 1 mg of 4-iodopyrazole carboxamide in 1 mL DMSO (Stock).

- Dilute to 10 µg/mL using 50:50 Methanol:Water + 0.1% Formic Acid.
- Validation Check: Ensure solution is clear; precipitation indicates poor solubility, leading to signal instability.
- LC Conditions:
  - Column: C18 Reverse Phase (e.g., Agilent Zorbax or Waters BEH), 2.1 x 50 mm, 1.7 µm.
  - Mobile Phase A: Water + 0.1% Formic Acid (Proton source for ESI).
  - Mobile Phase B: Acetonitrile (MeCN).
  - Gradient: 5% B to 95% B over 5 minutes.
- MS Settings (Triple Quadrupole):
  - Mode: Positive ESI ( )<sup>[1]</sup>
  - Capillary Voltage: 3.5 kV.
  - Collision Energy (CE) Ramping:
    - Low (10-15 eV): Preserves
    - Medium (20-30 eV): Promotes Amide loss ( )
    - High (>35 eV): Forces C-I cleavage ( )
- Data Interpretation (The "Truth" Test):
  - If the peak at

does not show a corresponding fragment at

, the compound is likely not the 4-iodo derivative (check for des-iodo impurity).

- Reference: For general pyrazole fragmentation rules, see Holzer et al. [1].

## Part 4: Structural Elucidation & Troubleshooting

### Distinguishing Regioisomers

Isomers where the iodine is at position 3 or 5 (rather than 4) exhibit different fragmentation kinetics.

- 4-Iodo: Sterically crowded if 3,5-disubstituted. Iodine loss is rapid to relieve strain.
- 3/5-Iodo: More stable. Requires higher CE to fragment.

### Common Artifacts

- Adducts: Watch for

(+22 Da) or

(+38 Da). These adducts often suppress fragmentation.

- Dimerization: Pyrazoles are H-bond donors. High concentrations may yield  
. Dilute the sample to confirm.

### References

- Holzer, W., et al. (2009). Pyrazoles: Synthesis and Mass Spectrometry. Heterocycles. (Generalized reference for pyrazole chemistry).
- Gross, J. H. (2017). Mass Spectrometry: A Textbook. Springer. (Source for ESI vs EI mechanisms).
- NIST Chemistry WebBook. Standard Reference Data for Pyrazole Derivatives.
- McLafferty, F. W. (1993). Interpretation of Mass Spectra. University Science Books.

### Need Custom Synthesis?

BenchChem offers custom synthesis for rare earth carbides and specific isotopic labeling.

Email: [info@benchchem.com](mailto:info@benchchem.com) or [Request Quote Online](#).

## Sources

- 1. A Mechanism Study on the (+)-ESI-TOF/HRMS Fragmentation of Some PPI Prazoles and Their Related Substances - PMC [[pmc.ncbi.nlm.nih.gov](https://pubmed.ncbi.nlm.nih.gov/)]
- To cite this document: BenchChem. [Comparative Mass Spectrometry Guide: Fragmentation Dynamics of 4-Iodopyrazole Carboxamides]. BenchChem, [2026]. [Online PDF]. Available at: [<https://www.benchchem.com/product/b11773335/docs#comparative-mass-spectrometry-guide-fragmentation-dynamics-of-4-iodopyrazole-carboxamides>]

### Disclaimer & Data Validity:

The information provided in this document is for Research Use Only (RUO) and is strictly not intended for diagnostic or therapeutic procedures. While BenchChem strives to provide accurate protocols, we make no warranties, express or implied, regarding the fitness of this product for every specific experimental setup.

**Technical Support:** The protocols provided are for reference purposes. Unsure if this reagent suits your experiment?

**Need Industrial/Bulk Grade?** [Request Custom Synthesis Quote](#)

## BenchChem

Our mission is to be the trusted global source of essential and advanced chemicals, empowering scientists and researchers to drive progress in science and industry.

### Contact

Address: 3281 E Guasti Rd

Ontario, CA 91761, United States

Phone: (601) 213-4426

Email: [info@benchchem.com](mailto:info@benchchem.com)

Contact our Ph.D. Support Team for a compatibility check