

Technical Guide: Potential Biological Activity of 5-Methylisothiazol-4-amine

Author: BenchChem Technical Support Team. **Date:** May 2026

Compound of Interest

Compound Name: 5-Methylisothiazol-4-amine

Cat. No.: B11770580

[Get Quote](#)

Executive Summary

5-Methylisothiazol-4-amine (CAS: 24340-76-9) represents a critical, under-utilized heteroaromatic scaffold in modern medicinal chemistry. While often overshadowed by its thiazole and isoxazole bioisosteres, the isothiazole core offers unique electronic properties and hydrogen-bonding capabilities that make it an ideal pharmacophore for fragment-based drug discovery (FBDD).

This technical guide analyzes the biological potential of this specific scaffold, positioning it not merely as a chemical intermediate, but as a "privileged structure" capable of generating diverse therapeutic agents ranging from kinase inhibitors to novel antimicrobials.

Part 1: Chemical Profile & Medicinal Chemistry

Context[1][2][3]

Structural Significance

The **5-methylisothiazol-4-amine** moiety consists of a five-membered aromatic ring containing adjacent sulfur and nitrogen atoms (

bond), substituted with a methyl group at the C5 position and a primary amine at the C4 position.

- **Bioisosterism:** It serves as a bioisostere for 4-aminothiazole and 4-aminoisoxazole. The bond imparts a higher dipole moment and different lipophilicity profile () compared to the or bonds in its analogs, influencing membrane permeability and target binding kinetics.
- **Electronic Profile:** The amine at C4 is electron-rich, serving as a versatile nucleophile for derivatization (acylation, alkylation, sulfonylation). The C5-methyl group provides metabolic stability (blocking metabolic oxidation at this position) and hydrophobic interaction potential within receptor pockets.

Physicochemical Properties (Predicted)

Property	Value (Approx.)	Significance
Molecular Weight	114.17 g/mol	Ideal for Fragment-Based Drug Design (Rule of 3)
LogP	0.6 - 0.9	High water solubility; good oral bioavailability potential
H-Bond Donors	2 (Amine)	Critical for receptor binding (e.g., hinge region of kinases)
H-Bond Acceptors	2 (Ring N, S)	Facilitates interactions with aqueous solvent or protein residues
pKa (Conj.[1] Acid)	~2.5 - 3.5	Weak base; likely uncharged at physiological pH, aiding passive transport

Part 2: Potential Biological Activities & Mechanisms[3]

Based on Structure-Activity Relationship (SAR) data of the broader isothiazole class, **5-Methylisothiazol-4-amine** derivatives exhibit potential in three primary therapeutic areas.

Kinase Inhibition (Oncology)

The 4-amino-isothiazole core mimics the adenine ring of ATP, allowing it to function as a hinge-binding motif in kinase inhibitors.

- Target: Serine/Threonine kinases (e.g., Aurora Kinases, CDK).
- Mechanism: The N-2 and the C-4 amino group form a donor-acceptor motif that hydrogen bonds with the kinase hinge region (e.g., Glu/Leu residues).
- Derivatization Strategy: Condensation of the C4-amine with aryl halides or heterocycles creates a "tail" that extends into the hydrophobic pocket of the enzyme.

Antimicrobial & Antifungal Activity

Isothiazoles are historically significant as biocides (e.g., isothiazolinones).[2][1][3] However, the aromatic 4-amine derivatives operate via different mechanisms.

- Target: Bacterial Cell Wall Synthesis (MurB/MurE ligases) or Fungal CYP51.
- Mechanism: Schiff bases derived from **5-methylisothiazol-4-amine** have shown efficacy by chelating metal ions essential for bacterial enzymes or by disrupting cell membrane integrity.
- Key Insight: The sulfur atom enhances lipophilicity, facilitating penetration through the waxy cell walls of Mycobacteria (potential anti-TB activity).

Anti-Inflammatory (COX-2 Inhibition)[3][6][7]

- Target: Cyclooxygenase-2 (COX-2).[4]
- Mechanism: Amide or urea derivatives of the scaffold can fit into the COX-2 side pocket. The isothiazole ring acts as a central template orienting the pharmacophores to achieve

selectivity over COX-1, reducing gastrointestinal side effects.

Part 3: Experimental Protocols

Protocol A: Synthesis of 5-Methylisothiazol-4-amine Precursor

Note: This is a validated route starting from 3-aminocrotonitrile.

Reagents: 3-Aminocrotonitrile, Carbon disulfide (

), Methyl iodide (

), Ammonia. Workflow:

- Formation of Dithiocarbamate: Treat 3-aminocrotonitrile with
 in the presence of a base (KOH) in DMF at 0°C.
- Methylation: Add
 dropwise to form the S-methyl intermediate.
- Cyclization: Treat the intermediate with oxidative agents (e.g., Iodine or Hydrogen Peroxide) or via nucleophilic attack by ammonia/hydroxylamine to close the isothiazole ring.
- Purification: Recrystallize from Ethanol/Water (9:1).

Protocol B: In Vitro Antimicrobial Assay (MIC Determination)

Objective: Determine the Minimum Inhibitory Concentration (MIC) of derivatives. Standard: CLSI M07-A10 Guidelines.

- Preparation: Dissolve **5-methylisothiazol-4-amine** derivatives in DMSO (Stock: 10 mg/mL).
- Inoculum: Prepare bacterial suspension (*S. aureus* ATCC 29213) adjusted to
 CFU/mL in Mueller-Hinton Broth.

- Plate Setup: Use 96-well microtiter plates. Dispense 100 μ L broth. Perform serial 2-fold dilutions of the compound (Range: 128 μ g/mL to 0.25 μ g/mL).
- Incubation: Add 100 μ L inoculum to each well. Incubate at 37°C for 18–24 hours.
- Readout: Visual inspection for turbidity or absorbance measurement at 600 nm ().
- Control: Positive control (Ciprofloxacin); Negative control (DMSO only).

Part 4: Visualizations & Logic Structures

Scaffold Versatility & SAR Logic

The following diagram illustrates how the **5-Methylisothiazol-4-amine** core is derivatized to access different biological targets.

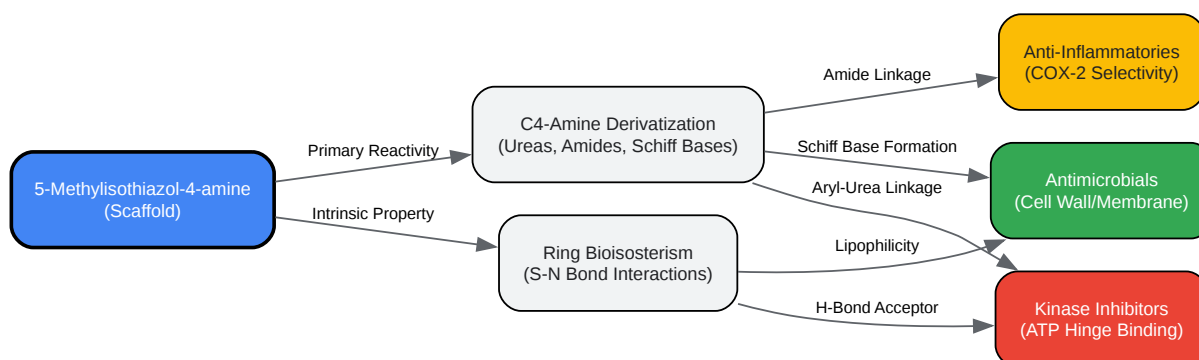

[Click to download full resolution via product page](#)

Caption: SAR logic flow demonstrating how specific chemical modifications of the core scaffold translate into distinct pharmacological activities.

Synthesis & Assay Workflow

This workflow outlines the critical path from raw material to validated biological data.

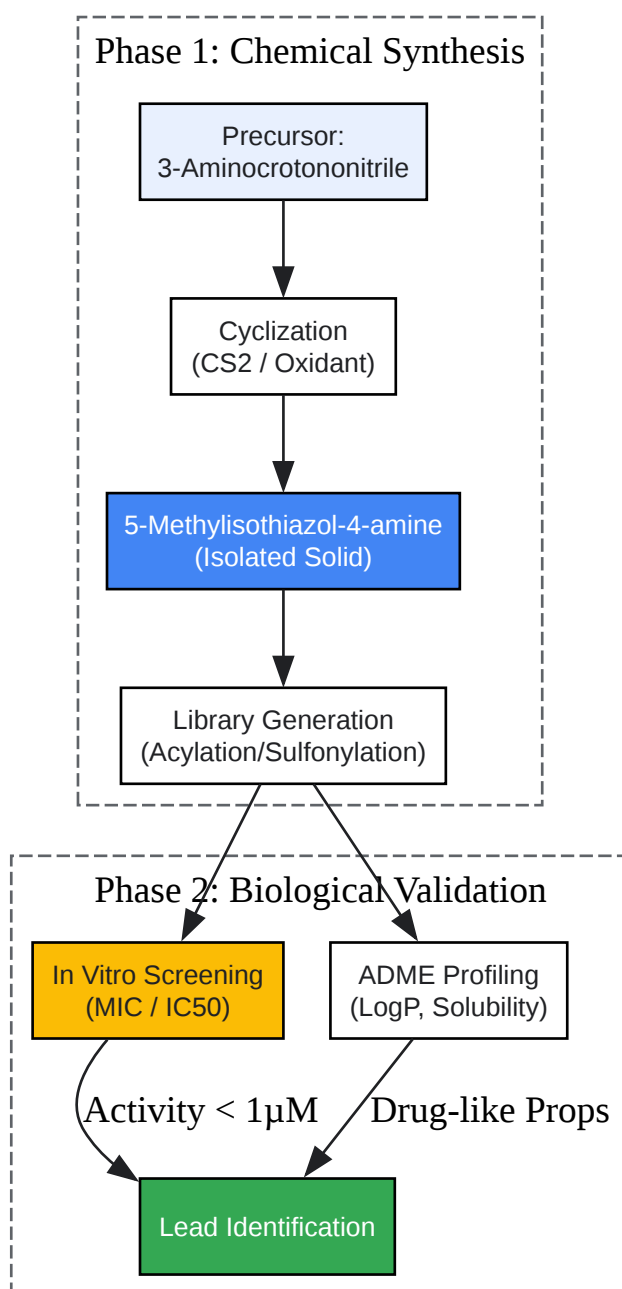

[Click to download full resolution via product page](#)

Caption: Integrated workflow for the synthesis of the scaffold and subsequent biological validation.

References

- Isothiazoles in Drug Discovery

- Title: Isothiazoles: Synthetic Strategies and Pharmacological Applications.[5][4][6]
- Source: Royal Society of Chemistry (Books).
- URL:[Link][2][4][3][7][8][9][10]
- Antimicrobial Potential of Thiazole/Isothiazole Amines
 - Title: Mode of Action of 5-Acetyl-4-Methylthiazole Deriv
 - Source: Malaysian Journal of Analytical Sciences.
 - URL:[Link]
- Anticancer Isothiazole Derivatives
 - Title: The N'-Substituted Derivatives of 5-Chloro-3-Methylisothiazole-4-Carboxylic Acid Hydrazide with Antiproliferative Activity.[11][12]
 - Source: N
 - URL:[Link]
- Synthetic Methods for Isothiazoles
 - Title: New isothiazole derivatives: synthesis, reactivity, physicochemical properties and pharmacological activity.
 - Source: PubMed.
 - URL:[Link]
- Patent Reference (FAAH Inhibitors)

Need Custom Synthesis?

BenchChem offers custom synthesis for rare earth carbides and specific isotopic labeling.

Email: info@benchchem.com or [Request Quote Online](#).

Sources

- [1. Isothiazolinone - Wikipedia \[en.wikipedia.org\]](#)
- [2. researchgate.net \[researchgate.net\]](#)
- [3. Methylisothiazolinone | C4H5NOS | CID 39800 - PubChem \[pubchem.ncbi.nlm.nih.gov\]](#)
- [4. mdpi.com \[mdpi.com\]](#)
- [5. Synthesis and Antioxidant Activity of 2-Amino-5-methylthiazol Derivatives Containing 1,3,4-Oxadiazole-2-thiol Moiety - PMC \[pmc.ncbi.nlm.nih.gov\]](#)
- [6. New derivatives of 5-amino-3-methyl-4-isothiazolecarboxylic acid and their immunological activity - PubMed \[pubmed.ncbi.nlm.nih.gov\]](#)
- [7. EP1998766A2 - Useful indole compounds - Google Patents \[patents.google.com\]](#)
- [8. WO2007070892A2 - Useful indole compounds - Google Patents \[patents.google.com\]](#)
- [9. 5-Ene-4-thiazolidinones – An efficient tool in medicinal chemistry - PMC \[pmc.ncbi.nlm.nih.gov\]](#)
- [10. Synthesis of 5-enamine-4-thiazolidinone derivatives with trypanocidal and anticancer activity - PubMed \[pubmed.ncbi.nlm.nih.gov\]](#)
- [11. The N'-Substituted Derivatives of 5-Chloro-3-Methylisothiazole-4-Carboxylic Acid Hydrazide with Antiproliferative Activity - PMC \[pmc.ncbi.nlm.nih.gov\]](#)
- [12. mdpi.com \[mdpi.com\]](#)
- To cite this document: BenchChem. [Technical Guide: Potential Biological Activity of 5-Methylisothiazol-4-amine]. BenchChem, [2026]. [Online PDF]. Available at: [\[https://www.benchchem.com/product/b11770580/docs#technical-guide-potential-biological-activity-of-5-methylisothiazol-4-amine\]](https://www.benchchem.com/product/b11770580/docs#technical-guide-potential-biological-activity-of-5-methylisothiazol-4-amine)

Disclaimer & Data Validity:

The information provided in this document is for Research Use Only (RUO) and is strictly not intended for diagnostic or therapeutic procedures. While BenchChem strives to provide accurate protocols, we make no warranties, express or implied, regarding the fitness of this product for every specific experimental setup.

Technical Support: The protocols provided are for reference purposes. Unsure if this reagent suits your experiment?

Need Industrial/Bulk Grade? [Request Custom Synthesis Quote](#)

BenchChem

Our mission is to be the trusted global source of essential and advanced chemicals, empowering scientists and researchers to drive progress in science and industry.

Contact

Address: 3281 E Guasti Rd

Ontario, CA 91761, United States

Phone: (601) 213-4426

Email: info@benchchem.com

[Contact our Ph.D. Support Team for a compatibility check](#)