

Validating Sar1's Role in Specific Cargo Export: A Comparative Guide

Author: BenchChem Technical Support Team. **Date:** April 2026

Compound of Interest

Compound Name:	Sar1 protein
CAS No.:	125524-15-4
Cat. No.:	B1177294

[Get Quote](#)

For Researchers, Scientists, and Drug Development Professionals

The protein Sar1, a small GTPase, is a cornerstone of the cellular machinery that transports newly synthesized proteins from the Endoplasmic Reticulum (ER). Its role as the initiator of COPII vesicle formation is well-established, but the nuances of its involvement in the export of specific cargo are a subject of ongoing investigation. This guide provides a comparative analysis of experimental approaches to validate the function of Sar1 in the export of a specific cargo protein, offering a framework for researchers designing experiments in this area.

The Central Role of Sar1 in COPII-Mediated ER Export

Sar1 functions as a molecular switch, cycling between an inactive GDP-bound state and an active GTP-bound state. This cycle initiates the assembly of the COPII coat on the ER membrane, a critical step for the formation of vesicles that transport cargo to the Golgi apparatus. The key steps in Sar1-mediated cargo export are:

- **Activation:** The ER-resident guanine nucleotide exchange factor (GEF), Sec12, catalyzes the exchange of GDP for GTP on Sar1.
- **Membrane Insertion:** GTP-bound Sar1 undergoes a conformational change, exposing an N-terminal amphipathic helix that inserts into the ER membrane.
- **Inner Coat Recruitment:** Membrane-bound Sar1-GTP recruits the Sec23/Sec24 inner coat complex. Sec24 isoforms are responsible for recognizing and binding specific cargo proteins.
- **Outer Coat Assembly:** The Sar1-Sec23/Sec24 pre-budding complex recruits the Sec13/Sec31 outer coat complex, which promotes membrane curvature and vesicle budding.
- **GTP Hydrolysis and Disassembly:** The inherent GTPase activity of Sar1, stimulated by the GAP activity of Sec23, leads to GTP hydrolysis. Sar1-GDP is released from the membrane, triggering the disassembly of the COPII coat from the vesicle, a prerequisite for its fusion with the Golgi.

The following diagram illustrates this signaling pathway:

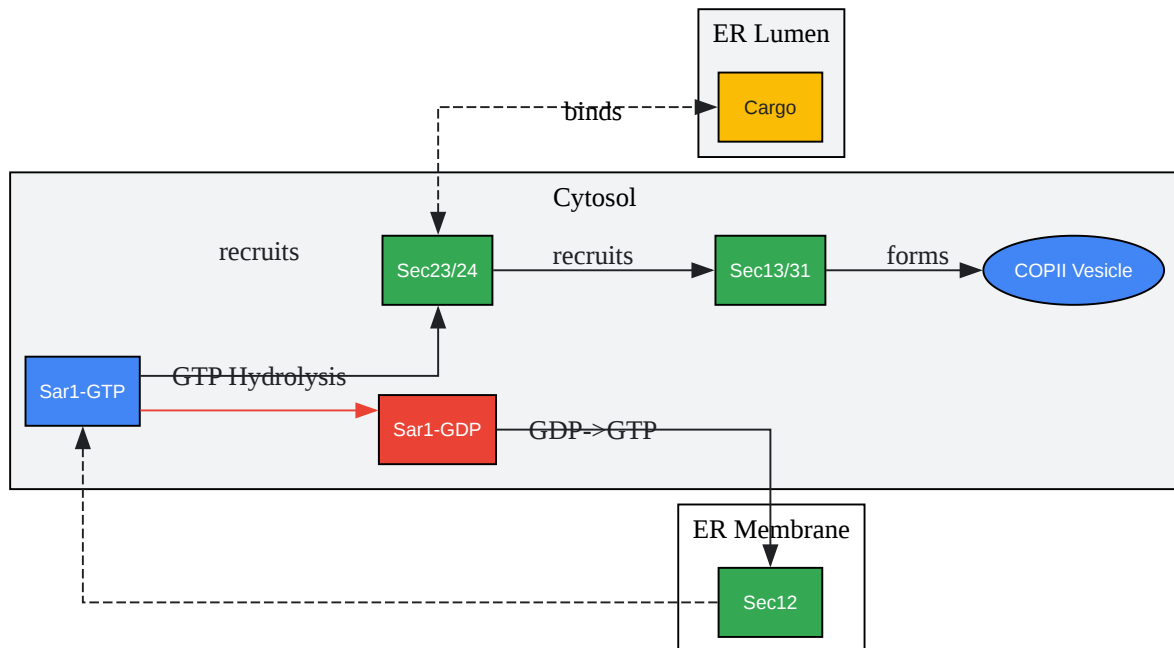

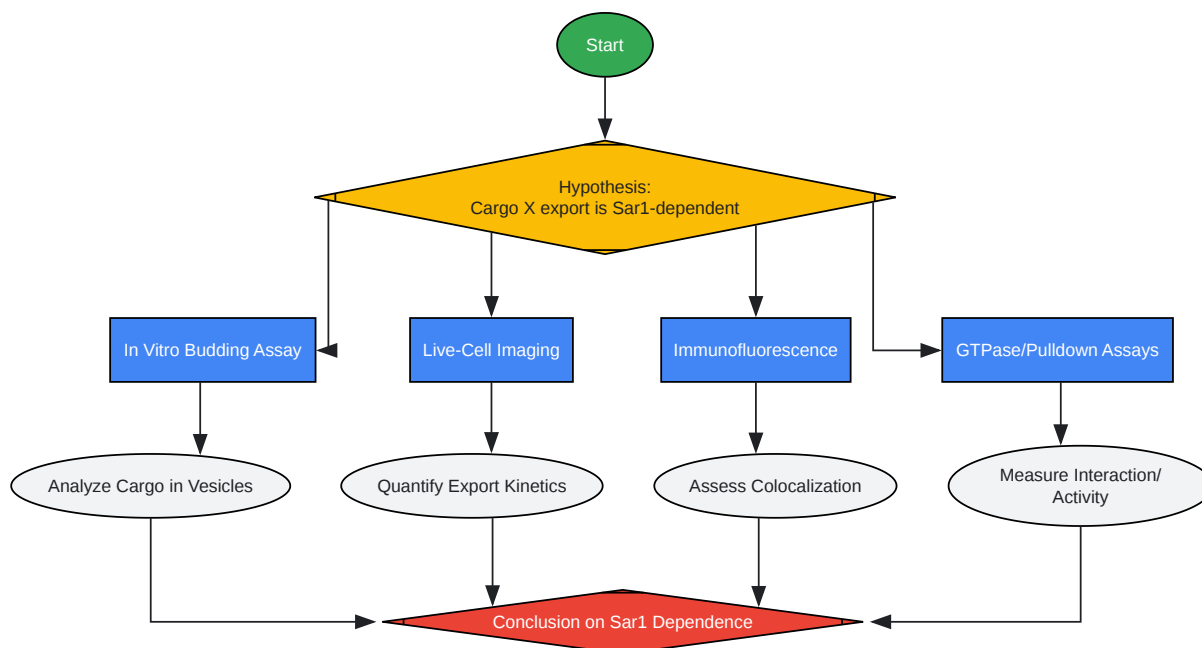

[Click to download full resolution via product page](#)

- To cite this document: BenchChem. [Validating Sar1's Role in Specific Cargo Export: A Comparative Guide]. BenchChem, [2026]. [Online PDF]. Available at: [\[https://www.benchchem.com/product/b1177294/docs#validating-sar1-s-role-in-specific-cargo-export-a-comparative-guide\]](https://www.benchchem.com/product/b1177294/docs#validating-sar1-s-role-in-specific-cargo-export-a-comparative-guide)

Disclaimer & Data Validity:

The information provided in this document is for Research Use Only (RUO) and is strictly not intended for diagnostic or therapeutic procedures. While BenchChem strives to provide accurate protocols, we make no warranties, express or implied, regarding the fitness of this product for every specific experimental setup.

Technical Support: The protocols provided are for reference purposes. Unsure if this reagent suits your experiment?

Need Industrial/Bulk Grade? [Request Custom Synthesis Quote](#)

BenchChem

Our mission is to be the trusted global source of essential and advanced chemicals, empowering scientists and researchers to drive progress in science and industry.

Contact

Address: 3281 E Guasti Rd
Ontario, CA 91761, United States
Phone: (601) 213-4426
Email: info@benchchem.com

[Contact our Ph.D. Support Team for a compatibility check](#)