

Application Notes and Protocols: Animal Models for Studying CD40L Function In Vivo

Author: BenchChem Technical Support Team. **Date:** May 2026

Compound of Interest

Compound Name: *CD40 Ligand*

CAS No.: *147205-72-9*

Cat. No.: *B1177011*

[Get Quote](#)

For Researchers, Scientists, and Drug Development Professionals

This document provides a detailed overview of various animal models used to investigate the in vivo functions of **CD40 ligand** (CD40L), a critical costimulatory molecule in the immune system. It includes comparative data on these models, detailed experimental protocols for key assays, and visualizations of relevant biological pathways and experimental workflows.

Introduction to CD40L

CD40 ligand (CD40L or CD154) is a transmembrane protein primarily expressed on activated T cells.[1] Its interaction with its receptor, CD40, which is present on antigen-presenting cells (APCs) like B cells, macrophages, and dendritic cells, is crucial for a wide range of immune responses.[1][2] This signaling axis plays a pivotal role in T cell-dependent B cell activation, immunoglobulin class switching, germinal center formation, and the generation of memory B cells.[1][3][4] Furthermore, the CD40/CD40L pathway is integral to the activation of APCs, leading to enhanced T cell priming and robust cell-mediated immunity.[4][5] Dysregulation of this pathway is implicated in various autoimmune diseases, transplant rejection, and cancer.[3]

Animal Models for In Vivo CD40L Research

The study of CD40L function in a whole-organism context relies heavily on the use of genetically engineered mouse models. These models can be broadly categorized into knockout, transgenic, and humanized mice, each offering unique advantages and limitations for specific research questions.

Comparative Data of Animal Models

Model Type	Strain/Name	Key Characteristics	Common Applications	Advantages	Limitations
Knockout	B6;129S-Cd40l ^{gtm1Imx/J} (CD40L KO)[6][7]	<ul style="list-style-type: none"> - X-linked mutation.[6] [7]- Deficient in T-cell dependent antibody responses. [8]- Lack of germinal center formation.[8]- Phenocopies human X-linked hyper-IgM syndrome.[6] [7][8] 	<ul style="list-style-type: none"> - Studying the fundamental roles of CD40L in humoral immunity.- Investigating the role of CD40L in autoimmune disease models.[9] [10]- Assessing the requirement for CD40L in transplantation models. 	<ul style="list-style-type: none"> - Complete absence of CD40L allows for clear investigation of its essential functions.- Well-characterized and widely available. 	<ul style="list-style-type: none"> - The complete lack of CD40L from birth may lead to developmental compensatory mechanisms.- May not be suitable for studying therapeutic agents that target CD40L.
Conditional Knockout	Tie2-Cre, Vav1-Cre, or CD4-Cre with floxed Cd40lg	<ul style="list-style-type: none"> - Cell type-specific deletion of CD40L (e.g., hematopoietic system, T cells).[11] 	<ul style="list-style-type: none"> - Dissecting the cell-specific contributions of CD40L to immune responses. 	<ul style="list-style-type: none"> - Allows for the study of CD40L function in specific cell lineages, avoiding potential embryonic lethality or widespread systemic effects. 	<ul style="list-style-type: none"> - Cre expression may not be 100% specific, leading to off-target deletion.- The timing of deletion can influence the observed phenotype.

Transgenic	CD40L Transgenic Mice	- Overexpression of CD40L, either constitutively or inducibly.	- Investigating the consequences of excessive CD40L signaling.- Modeling autoimmune conditions driven by CD40L overexpression.	- Allows for gain-of-function studies.	- Overexpression may not reflect physiological levels or regulation, potentially leading to artifacts.
Humanized	B-hCD40/hCD40L[12]	- Murine CD40 and CD40L are replaced by their human counterparts. [12]	- Preclinical in vivo evaluation of human-specific anti-CD40 and anti-CD40L therapeutic antibodies. [12]	- Provides a more relevant model for testing human therapeutics.- Enables the study of human-specific aspects of CD40/CD40L interactions.	- The human proteins are expressed in a murine cellular context, which may not fully recapitulate human immune responses.- Can be expensive to acquire and maintain.
Humanized	hCD40 Knock-in[13]	- The extracellular domain of mouse CD40 is replaced	- In vivo testing of agonistic anti-human CD40 antibodies for	- Allows for the in vivo assessment of human-	- The intracellular signaling domain is still murine, which

with the human sequence. [13] cancer immunotherapy. [2][13] specific CD40 agonists. might affect downstream signaling pathways compared to a fully human receptor.

CD40L Signaling Pathway

The engagement of CD40 on an APC by CD40L on an activated T cell triggers a cascade of intracellular signaling events. This leads to the recruitment of TNF receptor-associated factors (TRAFs) to the cytoplasmic tail of CD40, which in turn activates several downstream pathways, including the canonical and non-canonical NF- κ B pathways, as well as the MAPK and PI3K pathways. [3][5][14] These signaling cascades ultimately result in the upregulation of costimulatory molecules, production of cytokines, and enhanced survival of the APC, thereby amplifying the immune response.

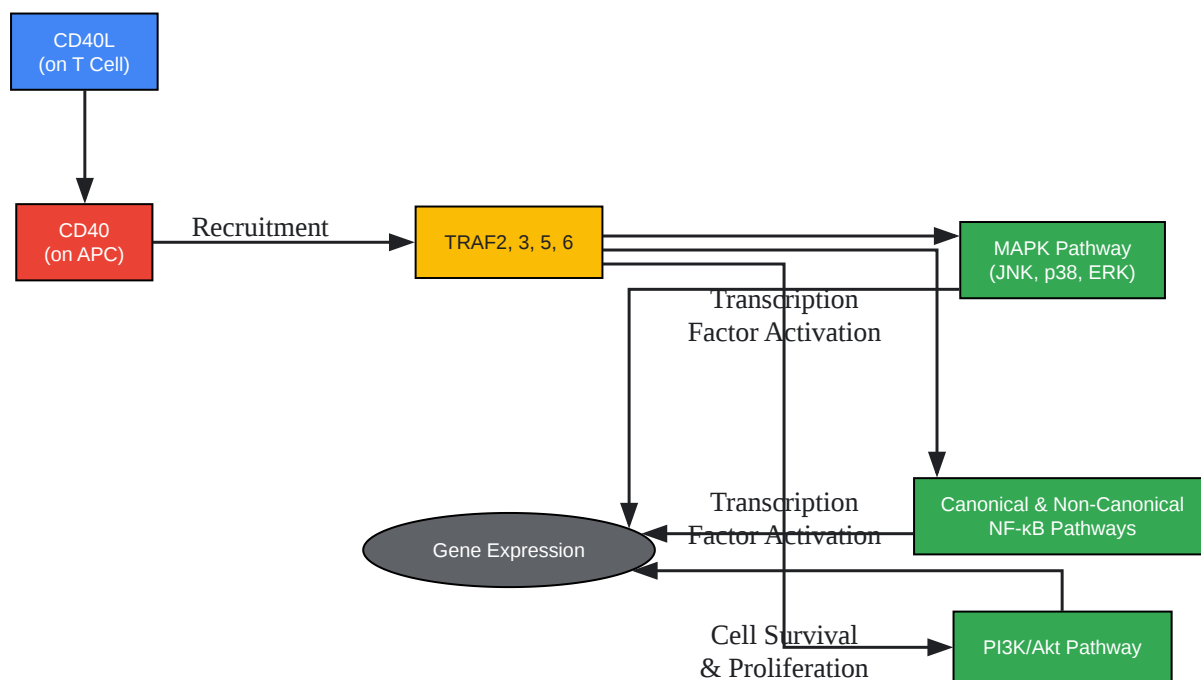

[Click to download full resolution via product page](#)

Figure 1: Simplified CD40L signaling pathway.

Experimental Protocols

Detailed methodologies for key in vivo experiments to study CD40L function are provided below.

Collagen-Induced Arthritis (CIA) Model

This model is widely used to study the pathogenesis of rheumatoid arthritis and to evaluate potential therapeutics. CD40L plays a critical role in the development of CIA.

Materials:

- Male DBA/1 mice, 8-10 weeks old[15][16]

- Bovine or chicken type II collagen (CII)
- Complete Freund's Adjuvant (CFA) containing Mycobacterium tuberculosis[15][16]
- Incomplete Freund's Adjuvant (IFA)
- 0.1 M acetic acid
- Syringes and needles (27G)
- Emulsifying needle or device

Protocol:

- Preparation of Collagen Emulsion:
 - Dissolve CII in 0.1 M acetic acid overnight at 4°C to a final concentration of 2 mg/mL.
 - On the day of immunization, prepare an emulsion by mixing the CII solution with an equal volume of CFA (for the primary immunization) or IFA (for the booster).
 - Emulsify the mixture until a stable emulsion is formed (a drop of the emulsion does not disperse in water). Keep the emulsion on ice.
- Primary Immunization (Day 0):
 - Anesthetize the mice.
 - Inject 100 µL of the CII/CFA emulsion intradermally at the base of the tail.[17]
- Booster Immunization (Day 21):
 - Inject 100 µL of the CII/IFA emulsion intradermally at a different site near the base of the tail.[15][17]
- Arthritis Scoring:
 - Beginning on day 21, monitor the mice 3-4 times a week for the onset and severity of arthritis.

- Score each paw on a scale of 0-4:
 - 0 = No evidence of erythema or swelling.
 - 1 = Erythema and mild swelling confined to the tarsals or ankle joint.
 - 2 = Erythema and mild swelling extending from the ankle to the tarsals.
 - 3 = Erythema and moderate swelling extending from the ankle to the metatarsal joints.
 - 4 = Erythema and severe swelling encompassing the ankle, foot, and digits.
- The maximum score per mouse is 16.
- Data Analysis:
 - Calculate the mean arthritis score for each group over time.
 - Determine the incidence of arthritis (percentage of mice with a score ≥ 1).

Experimental Autoimmune Encephalomyelitis (EAE) Model

EAE is the most commonly used animal model for the human inflammatory demyelinating disease, multiple sclerosis. The CD40/CD40L pathway is crucial for EAE induction.

Materials:

- Female C57BL/6 mice, 8-12 weeks old[18][19]
- Myelin oligodendrocyte glycoprotein (MOG)₃₅₋₅₅ peptide[12][20]
- Complete Freund's Adjuvant (CFA) containing Mycobacterium tuberculosis
- Pertussis toxin (PTX)
- Sterile PBS
- Syringes and needles (27G)

Protocol:

- Preparation of MOG Emulsion:
 - Dissolve MOG35-55 in sterile PBS to a final concentration of 2 mg/mL.
 - Prepare an emulsion by mixing the MOG solution with an equal volume of CFA.
- Immunization (Day 0):
 - Anesthetize the mice.
 - Inject 100 μ L of the MOG/CFA emulsion subcutaneously on the upper back.[\[20\]](#)
 - Inject another 100 μ L subcutaneously on the lower back.[\[20\]](#)
- Pertussis Toxin Administration:
 - On day 0 and day 2 post-immunization, inject 200 ng of PTX in 100 μ L of PBS intraperitoneally.
- Clinical Scoring:
 - Beginning on day 7, monitor the mice daily for clinical signs of EAE.
 - Score the mice on a scale of 0-5:[\[21\]](#)
 - 0 = No clinical signs.
 - 1 = Limp tail.
 - 2 = Hind limb weakness.
 - 3 = Hind limb paralysis.
 - 4 = Hind and forelimb paralysis.
 - 5 = Moribund or dead.

- Data Analysis:
 - Calculate the mean clinical score for each group over time.
 - Determine the day of onset and the peak disease severity.

Skin Transplantation Model

This model is used to study the mechanisms of allograft rejection, a process in which CD40L is critically involved.

Materials:

- Donor and recipient mice (e.g., BALB/c donor and C57BL/6 recipient for a fully MHC-mismatched model)
- Surgical instruments (scissors, forceps)
- Anesthetics
- Analgesics
- Bandaging material (e.g., Vaseline gauze, adhesive bandage)
- Sterile PBS

Protocol:

- Donor Skin Harvest:
 - Euthanize the donor mouse.
 - Shave the hair from the donor's back or use ear skin.[\[22\]](#)
 - Excise a full-thickness piece of skin (approximately 1x1 cm) and place it in sterile PBS on ice.[\[23\]](#)
 - Remove any excess fat and connective tissue from the underside of the graft.

- Recipient Preparation:
 - Anesthetize the recipient mouse and administer analgesia.[\[22\]](#)[\[24\]](#)
 - Shave a patch of hair on the recipient's flank.
 - Prepare a graft bed by excising a piece of full-thickness skin of the same size as the donor graft.[\[24\]](#)
- Graft Placement:
 - Place the donor skin graft onto the prepared graft bed.
 - Cover the graft with non-adherent gauze and secure it with a bandage.[\[24\]](#)
- Monitoring Graft Rejection:
 - Remove the bandage after 7 days.
 - Monitor the graft daily for signs of rejection (e.g., inflammation, necrosis, and eventual sloughing).
 - Graft rejection is typically defined as the day when more than 80% of the graft tissue is necrotic.
- Data Analysis:
 - Plot graft survival curves (Kaplan-Meier) and compare median survival times between groups.

Cancer Immunotherapy Model

The CD40/CD40L pathway is a promising target for cancer immunotherapy, as its activation can promote anti-tumor T cell responses.[\[2\]](#)[\[25\]](#)[\[26\]](#)

Materials:

- Syngeneic tumor cell line (e.g., MC38 colon adenocarcinoma for C57BL/6 mice)[\[13\]](#)

- C57BL/6 mice, 8-10 weeks old
- Agonistic anti-CD40 antibody or other CD40L-modulating therapeutic
- Sterile PBS or appropriate vehicle
- Calipers for tumor measurement
- Syringes and needles

Protocol:

- Tumor Inoculation:
 - Inject a suspension of tumor cells (e.g., 5×10^5 MC38 cells in 100 μ L PBS) subcutaneously into the flank of the mice.
- Treatment:
 - When tumors reach a palpable size (e.g., 50-100 mm³), randomize the mice into treatment and control groups.
 - Administer the therapeutic agent (e.g., agonistic anti-CD40 antibody) and vehicle control according to the desired dosing schedule (e.g., intraperitoneal injection).
- Tumor Measurement:
 - Measure the tumor volume every 2-3 days using calipers (Volume = $0.5 \times \text{length} \times \text{width}^2$).
- Endpoint:
 - Continue monitoring until tumors in the control group reach the maximum size allowed by institutional guidelines, or until a predetermined study endpoint.
- Data Analysis:
 - Plot mean tumor growth curves for each group.
 - Analyze survival data using Kaplan-Meier curves.

- At the end of the study, tumors and spleens can be harvested for immunological analysis (e.g., flow cytometry of tumor-infiltrating lymphocytes).

Experimental Workflow and Model Relationships

The selection of an appropriate animal model is crucial for the successful investigation of CD40L function. The following diagrams illustrate a typical experimental workflow and the logical relationships between the different types of animal models.

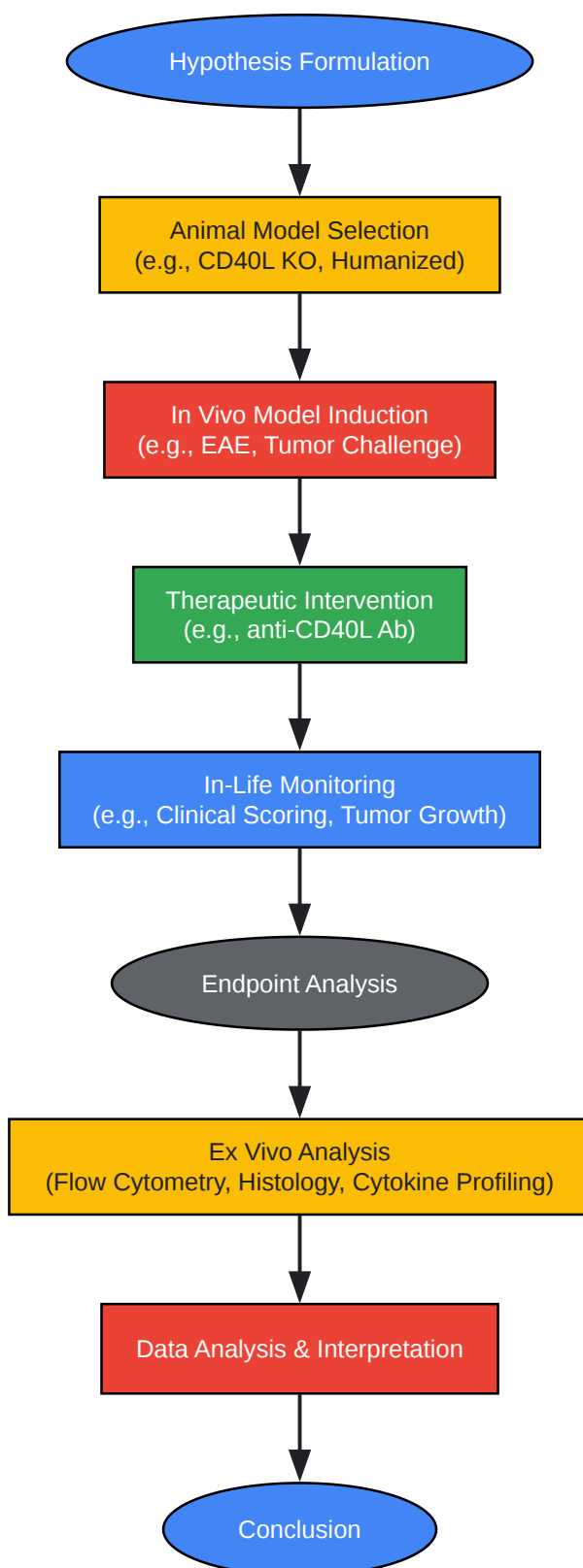

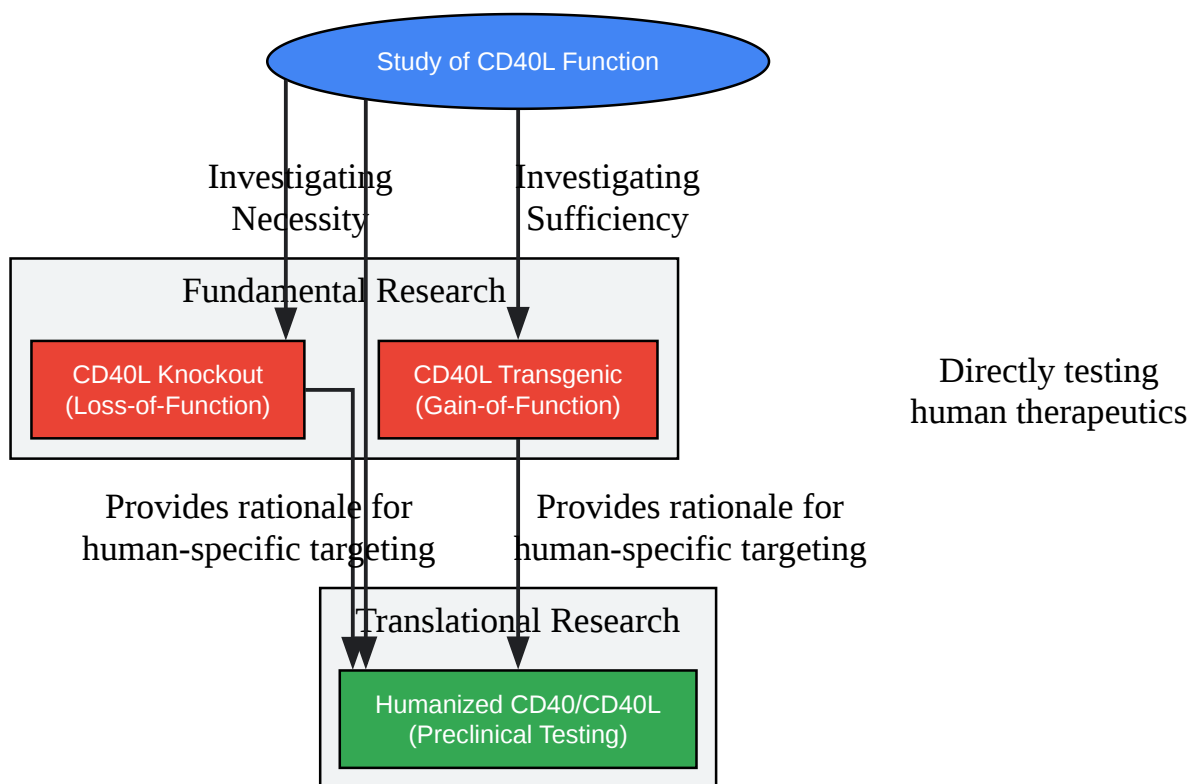

[Click to download full resolution via product page](#)

Need Custom Synthesis?

BenchChem offers custom synthesis for rare earth carbides and specific isotopic labeling.

Email: info@benchchem.com or [Request Quote Online](#).

References

- [1. adipogen.com \[adipogen.com\]](http://adipogen.com)
- [2. aacrjournals.org \[aacrjournals.org\]](http://aacrjournals.org)
- [3. Molecular mechanism and function of CD40/CD40L engagement in the immune system - PMC \[pmc.ncbi.nlm.nih.gov\]](http://pmc.ncbi.nlm.nih.gov)
- [4. creative-diagnostics.com \[creative-diagnostics.com\]](http://creative-diagnostics.com)
- [5. geneglobe.qiagen.com \[geneglobe.qiagen.com\]](http://geneglobe.qiagen.com)
- [6. 002428 - CD40 ligand KO Strain Details \[jax.org\]](http://jax.org)

- [7. 002770 - CD40 ligand KO Strain Details \[jax.org\]](#)
- [8. Mice deficient for the CD40 ligand - PubMed \[pubmed.ncbi.nlm.nih.gov\]](#)
- [9. Disruption of antigen-induced inflammatory responses in CD40 ligand knockout mice - PMC \[pmc.ncbi.nlm.nih.gov\]](#)
- [10. JCI - Disruption of antigen-induced inflammatory responses in CD40 ligand knockout mice. \[jci.org\]](#)
- [11. Generation of mice with conditional ablation of the Cd40lg gene: new insights on the role of CD40L - PubMed \[pubmed.ncbi.nlm.nih.gov\]](#)
- [12. biocytogen.com \[biocytogen.com\]](#)
- [13. cdn.prod.website-files.com \[cdn.prod.website-files.com\]](#)
- [14. researchgate.net \[researchgate.net\]](#)
- [15. chondrex.com \[chondrex.com\]](#)
- [16. resources.amsbio.com \[resources.amsbio.com\]](#)
- [17. Hooke - Protocols - CIA Induction in DBA/1 Mice \[hookelabs.com\]](#)
- [18. Experimental Autoimmune Encephalomyelitis in Mice - PMC \[pmc.ncbi.nlm.nih.gov\]](#)
- [19. scholars.northwestern.edu \[scholars.northwestern.edu\]](#)
- [20. Video: Author Spotlight: Creating a Versatile Experimental Autoimmune Encephalomyelitis Model Relevant for Both Male and Female Mice \[jove.com\]](#)
- [21. einsteinmed.edu \[einsteinmed.edu\]](#)
- [22. Murine Skin Transplantation - PMC \[pmc.ncbi.nlm.nih.gov\]](#)
- [23. Murine Full-thickness Skin Transplantation - PMC \[pmc.ncbi.nlm.nih.gov\]](#)
- [24. iacuc.ucsf.edu \[iacuc.ucsf.edu\]](#)
- [25. Hi-Affi™ Humanized CD40 Immune Checkpoint Knockin Mouse Model - Creative Biolabs \[creative-biolabs.com\]](#)
- [26. CD40 stimulation obviates innate sensors and drives T cell immunity in cancer - PMC \[pmc.ncbi.nlm.nih.gov\]](#)
- To cite this document: BenchChem. [Application Notes and Protocols: Animal Models for Studying CD40L Function In Vivo]. BenchChem, [2026]. [Online PDF]. Available at: [\[https://www.benchchem.com/product/b1177011/docs#application-notes-and-protocols-animal-models-for-studying-cd40l-function-in-vivo\]](https://www.benchchem.com/product/b1177011/docs#application-notes-and-protocols-animal-models-for-studying-cd40l-function-in-vivo)

Disclaimer & Data Validity:

The information provided in this document is for Research Use Only (RUO) and is strictly not intended for diagnostic or therapeutic procedures. While BenchChem strives to provide accurate protocols, we make no warranties, express or implied, regarding the fitness of this product for every specific experimental setup.

Technical Support: The protocols provided are for reference purposes. Unsure if this reagent suits your experiment?

Need Industrial/Bulk Grade? [Request Custom Synthesis Quote](#)

BenchChem

Our mission is to be the trusted global source of essential and advanced chemicals, empowering scientists and researchers to drive progress in science and industry.

Contact

Address: 3281 E Guasti Rd
Ontario, CA 91761, United States
Phone: (601) 213-4426
Email: info@benchchem.com

[Contact our Ph.D. Support Team for a compatibility check](#)