

Application Note: Analytical Characterization of 3-(1,1-Difluoropropyl)phenol

Author: BenchChem Technical Support Team. **Date:** May 2026

Compound of Interest

Compound Name: 3-(1,1-Difluoropropyl)phenol

Cat. No.: B11768747

[Get Quote](#)

Executive Summary & Scientific Rationale

3-(1,1-Difluoropropyl)phenol represents a critical class of fluorinated scaffolds in medicinal chemistry.^[1] The incorporation of the 1,1-difluoromethylene (

) moiety at the benzylic position serves two primary functions in drug design:

- **Metabolic Blocking:** It prevents rapid oxidative metabolism (hydroxylation) at the otherwise labile benzylic carbon (cytochrome P450 hotspot).

- **Bioisosterism:** The

group mimics the steric and electronic properties of a carbonyl oxygen or an ether oxygen while increasing lipophilicity (

).

This guide provides a definitive analytical framework for characterizing this molecule, distinguishing it from non-fluorinated analogs (e.g., 3-propylphenol) and regioisomers.

Physicochemical Profile (Predicted)

Before initiating wet-lab protocols, verify the material against these expected properties.

Property	Value / Range	Notes
Molecular Formula		
Molecular Weight	172.17 g/mol	Monoisotopic Mass: 172.07
Appearance	Colorless oil or low-melting solid	Phenols with short alkyl chains often exist as viscous oils at RT.[1][2][3]
Solubility	DMSO, Methanol, Chloroform, Ethyl Acetate	Limited water solubility; soluble in alkaline aqueous media (phenolate formation).
pKa (Phenol)	-9.5 - 9.8	Slightly more acidic than phenol (9.[1]95) due to the electron-withdrawing effect of the meta-group.

Method A: Nuclear Magnetic Resonance (NMR) Spectroscopy[4][5]

Rationale: NMR is the gold standard for structural verification.[1] The

nucleus provides a background-free diagnostic signal that confirms the presence of the difluoro motif.[1]

Protocol A1: Sample Preparation

- Solvent Selection: Use DMSO-

(0.6 mL) for the most reliable detection of the phenolic hydroxyl proton (

), which often exchanges/broadens in

[1]

- Concentration: Dissolve 10–15 mg of sample for

/

and 30–50 mg for

.

- Tube: Use high-precision 5mm NMR tubes to minimize shimming errors.

Protocol A2: Acquisition Parameters & Interpretation

1.

NMR (Diagnostic)

- Setup: Proton-decoupled () and coupled scans.
- Expected Signal: A strong singlet (decoupled) or triplet (coupled) in the range of -85 to -110 ppm.^[1]
- Coupling: The fluorine atoms couple to the adjacent methylene protons () of the propyl chain (Hz).

2.

NMR (The "Triplet" Signature)

The carbon skeleton reveals the definitive location of the fluorine atoms via Carbon-Fluorine coupling (

).

Carbon Position	Multiplicity	Coupling Constant ()	Explanation
Benzylic (C-F2)	Triplet (t)		Direct attachment to two Fluorines.[1]
Methylene (CH2)	Triplet (t)		Adjacent to group.
Aromatic C3	Triplet (t)		Ring carbon attached to .

3.

NMR (DMSO-

)

- ~9.6 ppm (s, 1H): Phenolic

(Exchangeable with

).

- ~6.8 - 7.3 ppm (m, 4H): Aromatic protons (meta-substitution pattern).[1]

- ~2.1 ppm (m, 2H): Methylene

(Coupled to both

and

).[1]

- ~0.9 ppm (t, 3H): Terminal methyl

.[1]

Method B: HPLC-UV/MS Purity Analysis[1]

Rationale: Phenols are weak acids.[1] Standard neutral mobile phases often result in peak tailing.[1] Acidic modification is strictly required to keep the phenol protonated (

) for sharp peak shape.[1]

Protocol B1: Chromatographic Conditions

Parameter	Setting
Column	C18 Reverse Phase (e.g., Agilent ZORBAX Eclipse Plus, 3.5 µm, 4.6 x 100 mm)
Mobile Phase A	Water + 0.1% Formic Acid (Maintains pH ~2. [1]7)
Mobile Phase B	Acetonitrile (ACN) + 0.1% Formic Acid
Flow Rate	1.0 mL/min
Injection Vol	5 µL
Detection	UV @ 210 nm (backbone) and 270 nm (phenol absorption)
Column Temp	40°C

Protocol B2: Gradient Table

Time (min)	% Mobile Phase B	Phase
0.0	5%	Equilibration
1.0	5%	Hold
10.0	95%	Linear Ramp
12.0	95%	Wash
12.1	5%	Re-equilibration
15.0	5%	End

Protocol B3: Mass Spectrometry (LC-MS)[1]

- Ionization Mode:ESI Negative (ESI-). Phenols ionize poorly in positive mode but readily form ions in negative mode.[1]
- Target Ion: Look for m/z 171.07 ().[1]

Method C: GC-MS Analysis (Volatility Check)[1]

Rationale: Due to the hydrogen-bonding capability of the phenol group, direct GC analysis can lead to adsorption in the liner.[1] Derivatization is recommended for quantification.[1]

Protocol C1: TMS Derivatization

- Take 1 mg of sample in a GC vial.[1]
- Add 200 μ L of BSTFA + 1% TMCS (Silylation reagent).
- Add 800 μ L of anhydrous Pyridine or Dichloromethane.
- Incubate at 60°C for 30 minutes.
- Result: The hydroxyl proton is replaced by a trimethylsilyl (TMS) group.[1]
 - New MW:
 - Target Ion:

Visualization of Analytical Workflow

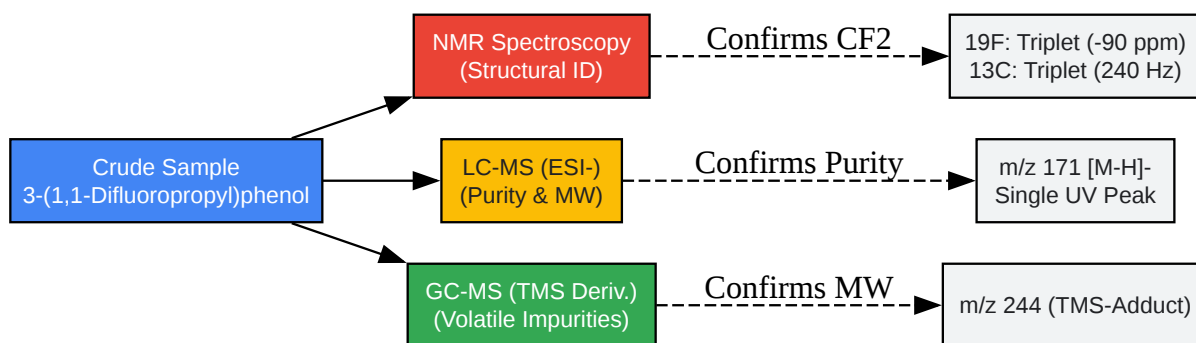

[Click to download full resolution via product page](#)

Figure 1: Integrated analytical workflow for the characterization of fluorinated phenols.

Troubleshooting & "Watch-Outs"

- Missing Phenol Peak in NMR: If using CDCl_3 , the phenol signal may broaden into the baseline due to water exchange.^[1] Switch to DMSO- d_6 to see a sharp singlet at >9.0 ppm.
- Ghost Peaks in NMR: The Carbon-Fluorine coupling splits signals into triplets or quartets.^[1] Do not mistake these multiplets for impurities.^[1] Calculate the coupling constant (J_{CF}) to verify.
- Low Sensitivity in LC-MS: Ensure you are in Negative Mode. If signal is still low, add trace Ammonium Acetate (5mM) to the mobile phase to assist ionization, though Formic Acid is usually sufficient for phenols.

References

- Metabolic Stability of Fluorinated Motifs
 - Hagens, et al. "Fluorine in Medicinal Chemistry." Topics in Current Chemistry.

- Source:
- NMR Chemical Shifts of Fluorinated Groups
 - Reich, H. J. "Bordwell pKa Table & NMR Data." University of Wisconsin.[1][4]
 - Source:
- Phenol Analysis Methods (EPA Method 8041)
 - "Phenols by Gas Chromatography." [1][3][5] US EPA SW-846.[1]
 - Source:
- General LC-MS of Phenolic Compounds
 - "Characterization of Phenolic Compounds by LC-MS/MS."
 - Source:

Need Custom Synthesis?

BenchChem offers custom synthesis for rare earth carbides and specific isotopic labeling.

Email: info@benchchem.com or [Request Quote Online](#).

Sources

- [1. epa.gov \[epa.gov\]](http://epa.gov)
- [2. 3-isopropyl phenol, 618-45-1 \[thegoodscentcompany.com\]](http://thegoodscentcompany.com)
- [3. settek.com \[settek.com\]](http://settek.com)
- [4. organicchemistrydata.org \[organicchemistrydata.org\]](http://organicchemistrydata.org)
- [5. ANALYTICAL METHODS - Toxicological Profile for Phenol - NCBI Bookshelf \[ncbi.nlm.nih.gov\]](http://ncbi.nlm.nih.gov)
- To cite this document: BenchChem. [Application Note: Analytical Characterization of 3-(1,1-Difluoropropyl)phenol]. BenchChem, [2026]. [Online PDF]. Available at:

[\[https://www.benchchem.com/product/b11768747/docs#application-note-analytical-characterization-of-3-1-1-difluoropropyl-phenol\]](https://www.benchchem.com/product/b11768747/docs#application-note-analytical-characterization-of-3-1-1-difluoropropyl-phenol)

Disclaimer & Data Validity:

The information provided in this document is for Research Use Only (RUO) and is strictly not intended for diagnostic or therapeutic procedures. While BenchChem strives to provide accurate protocols, we make no warranties, express or implied, regarding the fitness of this product for every specific experimental setup.

Technical Support: The protocols provided are for reference purposes. Unsure if this reagent suits your experiment?

Need Industrial/Bulk Grade? [Request Custom Synthesis Quote](#)

BenchChem

Our mission is to be the trusted global source of essential and advanced chemicals, empowering scientists and researchers to drive progress in science and industry.

Contact

Address: 3281 E Guasti Rd
Ontario, CA 91761, United States
Phone: (601) 213-4426
Email: info@benchchem.com

[Contact our Ph.D. Support Team for a compatibility check](#)