

Mass Spectrometry Fragmentation Patterns of SCF3-Substituted Pyridinones

Author: BenchChem Technical Support Team. **Date:** April 2026

Compound of Interest

Compound Name: 3-(Trifluoromethylthio)pyridin-4(1H)-one
Cat. No.: B11761608

[Get Quote](#)

Executive Summary

The trifluoromethylthio (

) group has emerged as a "privileged pharmacophore" in modern drug design, offering superior lipophilicity (Hansch

) compared to its oxygen analogue (

) and the trifluoromethyl group (

). When attached to a pyridinone scaffold—a common structural motif in kinase inhibitors and analgesics—the

group presents unique mass spectrometric challenges and diagnostic opportunities.

This guide provides a technical comparison of the fragmentation behaviors of

-substituted pyridinones versus their

analogues. By understanding the distinct bond dissociation energies and rearrangement pathways, researchers can confidently identify metabolites and impurities during the drug development lifecycle.

The Chemical Context: Why vs. Matters

In medicinal chemistry, the substitution of an oxygen atom with a sulfur atom (bioisosteric replacement) dramatically alters the fragmentation landscape due to the differences in bond strength and polarizability.

Comparative Bond Dissociation Energies (BDE)

The primary driver of the divergent fragmentation patterns is the stability of the heteroatom-carbon bonds:

- : The

bond is relatively strong (

90-100 kcal/mol), often resisting direct cleavage.[1]

- : The

bond is significantly weaker (

65-70 kcal/mol).[1]

Impact on MS/MS: Under Collision-Induced Dissociation (CID),

-pyridinones exhibit a lower energy threshold for substituent loss compared to

-pyridinones.[1] While

compounds often undergo complex internal rearrangements (losing

),

compounds frequently display direct homolytic cleavage or loss of the terminal

moiety.

Fragmentation Mechanics: The Core Analysis

The Pyridinone Core (Common Pathway)

Regardless of the substituent, the pyridinone backbone follows a canonical fragmentation pathway driven by the lactam-lactim tautomerism.

- Primary Event: Loss of Carbon Monoxide (CO, 28 Da).
- Secondary Event: Ring contraction, often followed by the loss of HCN (27 Da).

The Specific Pathways

The sulfur atom introduces "soft" nucleophilicity, facilitating pathways that are inaccessible to the "hard" oxygen analogue.

- Pathway A: Direct Homolytic Cleavage (Diagnostic) The weakness of the

bond leads to the direct loss of the

radical (69 Da) or the neutral loss of

(70 Da) if hydrogen rearrangement occurs.

- Observation: High abundance of

or

[.\[1\]](#)

- Pathway B: C-S Cleavage In higher energy collisions, the entire

group can be cleaved.

- Observation: Loss of 101 Da (

[\).\[1\]](#)

The Alternative (Contrast)

Unlike the

group, the

group rarely loses the

radical directly. Instead, it favors a rearrangement eliminating carbonyl difluoride (

).[1]

- Mechanism:[1][2][3][4][5][6] Fluorine migration to the aromatic ring followed by C-O cleavage.
- Observation: Neutral loss of 66 Da (), leaving a fluorine atom on the heterocyclic ring ().[1]

Experimental Protocol: LC-MS/MS Characterization

To replicate these fragmentation patterns for structural elucidation, follow this standardized ESI-QTOF protocol.

Reagents & Preparation

- Solvent A: Water + 0.1% Formic Acid (Proton source for).[1]
- Solvent B: Acetonitrile (LC-MS Grade).[1]
- Concentration: 1 µg/mL in 50:50 MeOH:H₂O.

Instrument Parameters (Agilent 6545 Q-TOF or Equivalent)

Parameter	Setting	Rationale
Ionization Source	ESI Positive (+)	Pyridinones protonate readily at the carbonyl oxygen.[1]
Capillary Voltage	3500 V	Standard for stable spray in positive mode.[1]
Fragmentor	110 V	Optimized to prevent in-source fragmentation of the labile C-S bond.[1]
Collision Energy (CE)	10, 20, 40 eV	Stepped CE is critical. Low CE preserves the ; High CE reveals the core.
Gas Temp	300°C	Ensures desolvation without thermal degradation.[1]
Acquisition Range	50 - 1000 m/z	Captures low mass diagnostic ions (at m/z 69).[1]

Step-by-Step Workflow

- Direct Infusion: Initially infuse the sample at 10 $\mu\text{L}/\text{min}$ to determine the optimal precursor ion .
- MS2 Optimization: Apply a collision energy ramp (0-60 eV).
- Observation: Note the onset of the m/z 69 peak () vs. the loss of 28 Da (CO). For compounds, the m/z 69 ion often appears at lower CE than in analogues.
- LC Separation: Use a C18 column (e.g., Zorbax Eclipse Plus).[1]

variants will elute later than

variants due to higher lipophilicity.[\[1\]](#)

Data Comparison: Diagnostic Ion Table

The following table summarizes the key differences to look for when distinguishing between these bioisosteres.

Feature	-Pyridinone	-Pyridinone	Interpretation
Precursor Ion			Base peak.[1]
Primary Neutral Loss	69 Da () or 70 Da ()	66 Da ()	CRITICAL DISTINCTION. loses the fluorinated tail; rearranges.[1]
Secondary Loss	28 Da (CO)	28 Da (CO)	Characteristic of the pyridinone ring.[1]
Diagnostic Fragment	m/z 69 ()	m/z 69 ()	Present in both, but typically higher relative abundance in spectra at lower CE. [1]
Retention Time	Late Eluting	Early/Mid Eluting	is significantly more lipophilic ().[1]
C-Heteroatom Stability	Low (Weak C-S bond)	High (Strong C-O bond)	compounds show more "in-source" fragmentation if voltages are too high. [1]

Visualization: Fragmentation Pathway[1]

The following diagram illustrates the divergent pathways for an

-substituted pyridinone (Protonated Parent) under Collision-Induced Dissociation.

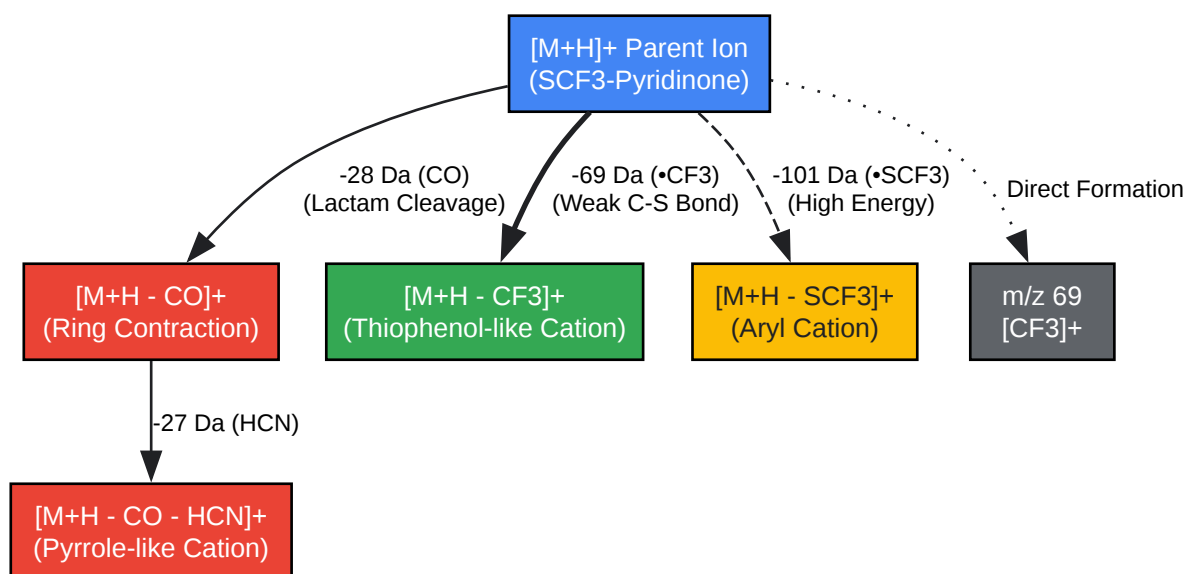

[Click to download full resolution via product page](#)

Caption: Figure 1. Proposed ESI-MS/MS fragmentation pathways for SCF₃-substituted pyridinones. The green pathway (Loss of CF₃) represents the primary differentiator from OCF₃ analogues.

References

- Hansch, C., & Leo, A. (1995). Exploring QSAR: Fundamentals and Applications in Chemistry and Biology. American Chemical Society.[1] (Source for constants and lipophilicity data).
- Shao, X., et al. (2022).[1][3] "Metal-catalyzed Radical Trifluoromethylthiolation of Aryl Boronic Acids." ChemCatChem. Available at: [\[Link\]](#) (Mechanistic insight into radical stability of SCF₃).[1]
- Kagramanov, N. D., et al. (2021).[1] "Ionic Series in Mass Spectra of Trifluoromethyl-Substituted Heterocycles." Fluorine Notes, 138(5-6).[1] Available at: [\[Link\]](#) (Fragmentation patterns of CF₃-heterocycles).
- Leroux, F. R., et al. (2015).[1] "Synthesis of Trifluoromethoxylated (Hetero)Arenes via OCF₃ Migration." Chemistry - A European Journal.[1] Available at: [\[Link\]](#) (Comparative analysis of OCF₃ vs SCF₃ properties and bond behaviors).

- BenchChem Technical Support. (2025). "3-(Trifluoromethyl)-2-pyridone Structure and Properties." PubChem CID 3678411. Available at: [\[Link\]](#).^[1]

Need Custom Synthesis?

BenchChem offers custom synthesis for rare earth carbides and specific isotopic labeling.

Email: info@benchchem.com or [Request Quote Online](#).

Sources

- 1. 2(1H)-Pyridinone, 3-(trifluoromethyl)- | C₆H₄F₃NO | CID 3678411 - PubChem [\[pubchem.ncbi.nlm.nih.gov\]](https://pubchem.ncbi.nlm.nih.gov)
- 2. mdpi.com [\[mdpi.com\]](https://mdpi.com)
- 3. researchgate.net [\[researchgate.net\]](https://researchgate.net)
- 4. Synthesis of Trifluoromethoxylated (Hetero)Arenes via OCF₃ Migration - PMC [\[pmc.ncbi.nlm.nih.gov\]](https://pmc.ncbi.nlm.nih.gov)
- 5. [Projectdetail - FWF](https://projectdetail.fwf.ac.at) [\[fwf.ac.at\]](https://projectdetail.fwf.ac.at)
- 6. par.nsf.gov [\[par.nsf.gov\]](https://par.nsf.gov)
- To cite this document: BenchChem. [Mass Spectrometry Fragmentation Patterns of SCF₃-Substituted Pyridinones]. BenchChem, [2026]. [Online PDF]. Available at: [\[https://www.benchchem.com/product/b11761608/docs#mass-spectrometry-fragmentation-patterns-of-scf3-substituted-pyridinones\]](https://www.benchchem.com/product/b11761608/docs#mass-spectrometry-fragmentation-patterns-of-scf3-substituted-pyridinones)

Disclaimer & Data Validity:

The information provided in this document is for Research Use Only (RUO) and is strictly not intended for diagnostic or therapeutic procedures. While BenchChem strives to provide accurate protocols, we make no warranties, express or implied, regarding the fitness of this product for every specific experimental setup.

Technical Support: The protocols provided are for reference purposes. Unsure if this reagent suits your experiment?

Need Industrial/Bulk Grade? [Request Custom Synthesis Quote](#)

BenchChem

Our mission is to be the trusted global source of essential and advanced chemicals, empowering scientists and researchers to drive progress in science and industry.

Contact

Address: 3281 E Guasti Rd

Ontario, CA 91761, United States

Phone: (601) 213-4426

Email: info@benchchem.com

[Contact our Ph.D. Support Team for a compatibility check](#)