

# Fluorinated PCB 37 congener properties

**Author:** BenchChem Technical Support Team. **Date:** April 2026

## Compound of Interest

Compound Name: *3,4,4'-Trichloro-3'-fluoro-1,1'-biphenyl*

Cat. No.: *B11760347*

[Get Quote](#)

Technical Monograph: Fluorinated Analogs of PCB 37 (F-PCB 37) Congener Focus: 3'-Fluoro-3,4,4'-Trichlorobiphenyl and Related Isosteres

## Part 1: Executive Technical Synthesis

The study of Polychlorinated Biphenyls (PCBs) has evolved from simple environmental monitoring to complex mechanistic toxicology. PCB 37 (3,4,4'-Trichlorobiphenyl) is a non-ortho, coplanar congener that exhibits "dioxin-like" toxicity via Aryl Hydrocarbon Receptor (AhR) activation. However, its metabolic activation pathways—specifically the formation of hydroxylated metabolites (OH-PCBs) and quinones—remain a critical area of investigation for neurotoxicity and endocrine disruption.

Fluorinated PCB 37 (F-PCB 37) congeners, particularly 3'-F-PCB 37, represent a specialized class of "metabolic probes" and analytical standards. By substituting a hydrogen atom with fluorine (a bioisostere) at specific positions, researchers can:

- **Block Metabolic Sites:** Fluorine's strong C-F bond (approx. 116 kcal/mol) prevents oxidative metabolism at the substitution site, allowing scientists to determine if toxicity is driven by the parent compound or a specific metabolite.

- Serve as Internal Standards: F-PCBs do not occur naturally. Their unique mass spectral fragmentation and retention time shifts make them ideal internal standards for quantifying native PCB 37 in complex biological matrices (blood, adipose tissue).

## Part 2: Physicochemical & Structural Properties

The introduction of a fluorine atom into the PCB 37 scaffold alters its electronic and steric landscape without destroying the core biphenyl geometry.

### Structural Comparison

Property	Native PCB 37	3'-F-PCB 37 (Fluorinated Analog)
IUPAC Name	3,4,4'-Trichlorobiphenyl	3'-Fluoro-3,4,4'-Trichlorobiphenyl
Structure	Non-ortho, Coplanar	Non-ortho, Coplanar (Bioisostere)
Substituents	Cl at 3, 4, 4'	Cl at 3, 4, 4'; F at 3'
Metabolic "Soft Spots"	2,3 (Ring 1); 2',3' (Ring 2); 5,6 (Ring 1)	3' Blocked; 2,3 (Ring 1) remains open
Lipophilicity (LogP)	~5.7 - 5.9	Slightly Higher (F is more lipophilic than H)
Electronic Effect	Cl withdraws electrons	F is strongly electronegative (Inductive effect)

### The "Fluorine Effect" in Toxicology

Fluorine is often called a "metabolic shield." In PCB 37, the 4'-chlorophenyl ring is susceptible to enzymatic attack at the 2',3' position (forming an arene oxide) or direct insertion at the 3' position.

- Mechanism: Replacing the 3'-Hydrogen with Fluorine prevents Cytochrome P450 (CYP) enzymes from hydroxylating this position.

- Result: If 3'-F-PCB 37 is less toxic than PCB 37 in an assay, it implies that 3'-hydroxylation is a toxication step (required for toxicity). If toxicity remains unchanged, the parent PCB 37 is the toxic agent.

## Part 3: Applications in Drug Development & Toxicology

### Mechanistic Neurotoxicity Studies

Recent research indicates PCB 37 promotes dendritic growth and apoptosis in neurons via CREB signaling (See Sethi et al. in References).

- Application: Researchers use F-PCB 37 to treat neuronal cultures.
- Hypothesis: If the neurotoxic effect (e.g., dendritic arborization) is abolished in the F-PCB 37 group, the effect is likely mediated by a 3'-OH-PCB 37 metabolite rather than the parent congener.

### Analytical Internal Standards (ID-MS)

In Isotope Dilution Mass Spectrometry (ID-MS),

C-labeled PCBs are standard. However, F-PCBs offer a cost-effective alternative with distinct chromatographic properties.

- Retention Time Shift: The high electronegativity of fluorine alters the interaction with GC stationary phases (e.g., DB-5ms), causing F-PCB 37 to elute slightly earlier or later than native PCB 37, preventing co-elution while remaining within the same window.
- Mass Spec: The molecular ion  $[M]^+$  will show a +18 Da shift (replacing H [1] with F [19]) compared to the parent, or a specific mass difference depending on the degree of chlorination.

## Part 4: Experimental Protocols

### Protocol A: Comparative In Vitro Metabolism Assay

Objective: Determine the metabolic stability of F-PCB 37 vs. Native PCB 37 to validate the "blocking" effect.

**Reagents:**

- Liver Microsomes (Rat or Human)
- NADPH Regenerating System
- Substrates: PCB 37 and 3'-F-PCB 37 (10  $\mu$ M final conc.)
- Quenching Agent: Ice-cold Acetonitrile

**Workflow:**

- Pre-incubation: Mix 20  $\mu$ L microsomes (20 mg/mL protein) with phosphate buffer (pH 7.4). Equilibrate at 37°C for 5 min.
- Substrate Addition: Add PCB 37 to Group A and 3'-F-PCB 37 to Group B.
- Initiation: Add NADPH regenerating system to start the reaction.
- Time Course: Aliquot samples at 0, 15, 30, and 60 minutes.
- Termination: Quench immediately with 1:1 volume of Acetonitrile.
- Extraction: Liquid-Liquid extraction with Hexane/MTBE.
- Analysis: Analyze via GC-MS/MS (See Protocol B).

Expected Result: PCB 37 should show a decrease in parent concentration and appearance of OH-PCB peaks. 3'-F-PCB 37 should show significantly higher stability (minimal loss of parent) if the 3' position is the primary metabolic site.

## Protocol B: GC-MS/MS Quantification Parameters

Objective: Separate and quantify F-PCB 37.

- Column: Rtx-PCB or DB-5ms (30m x 0.25mm x 0.25 $\mu$ m).
- Carrier Gas: Helium at 1.0 mL/min (constant flow).

- Inlet: Splitless, 280°C.
- Oven Program:
  - Start: 100°C (hold 1 min)
  - Ramp 1: 20°C/min to 200°C
  - Ramp 2: 2°C/min to 260°C (Critical for congener separation)
  - End: 300°C (hold 5 min)
- MS Source: EI (70 eV), 230°C.
- SIM Mode Ions (Example):
  - PCB 37: m/z 256, 258 (M+)
  - 3'-F-PCB 37: m/z 274, 276 (M+) (Mass shift due to F)

## Part 5: Visualization of Metabolic Logic

The following diagram illustrates the "Metabolic Blocking" concept using F-PCB 37.

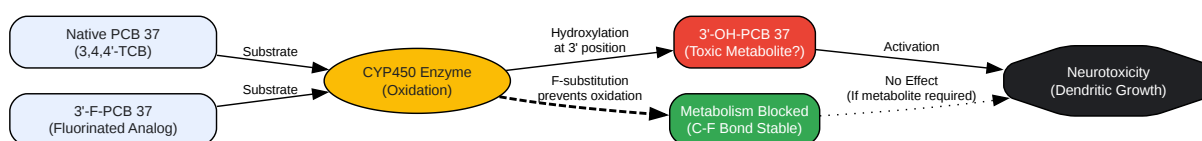

[Click to download full resolution via product page](#)

Figure 1: Mechanism of Action for Fluorinated PCB 37 as a metabolic probe. By blocking the 3' position, researchers can distinguish between parent-compound toxicity and metabolite-mediated toxicity.

## Part 6: Analytical Workflow Diagram

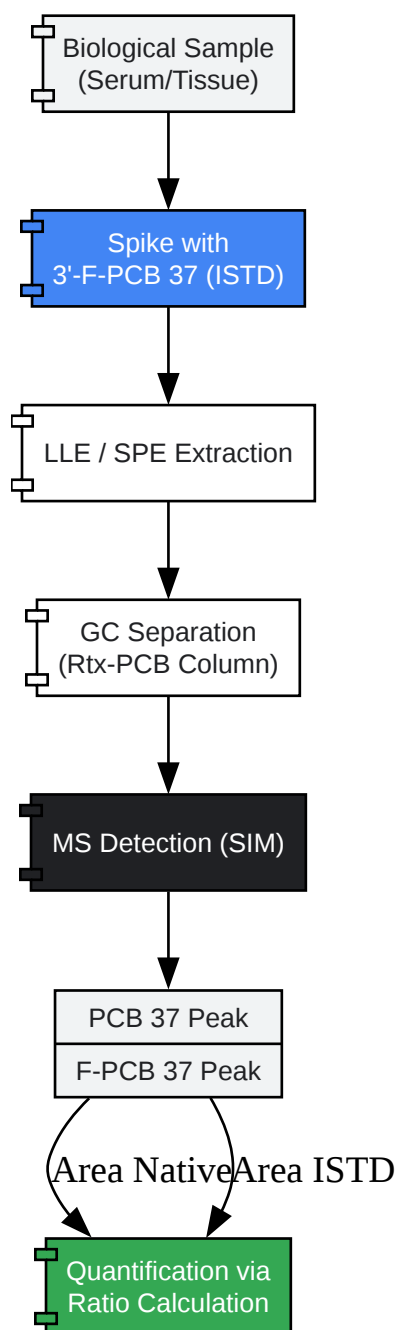

[Click to download full resolution via product page](#)

Figure 2: Workflow for using 3'-F-PCB 37 as an Internal Standard (ISTD) for accurate quantification of environmental PCB 37 exposure.

## References

- Sethi, S., Keil, K. P., & Lein, P. J. (2018). PCB 37 (3,4,4'-trichlorobiphenyl) increased apoptosis and modulated neuronal morphogenesis in primary cortical rat neurons.

eScholarship. Retrieved March 7, 2026, from [[Link](#)]

- Chiron AS. (n.d.). Fluorinated PCBs (F-PCBs) Standards. Chiron. Retrieved March 7, 2026, from [[Link](#)]
- Grimm, F. A., et al. (2015). Metabolism and metabolites of polychlorinated biphenyls. National Institutes of Health (PMC). Retrieved March 7, 2026, from [[Link](#)]
- To cite this document: BenchChem. [Fluorinated PCB 37 congener properties]. BenchChem, [2026]. [Online PDF]. Available at: [<https://www.benchchem.com/product/b11760347/docs#fluorinated-pcb-37-congener-properties>]

---

### Disclaimer & Data Validity:

The information provided in this document is for Research Use Only (RUO) and is strictly not intended for diagnostic or therapeutic procedures. While BenchChem strives to provide accurate protocols, we make no warranties, express or implied, regarding the fitness of this product for every specific experimental setup.

**Technical Support:** The protocols provided are for reference purposes. Unsure if this reagent suits your experiment?

**Need Industrial/Bulk Grade?** [Request Custom Synthesis Quote](#)

## BenchChem

Our mission is to be the trusted global source of essential and advanced chemicals, empowering scientists and researchers to drive progress in science and industry.

### Contact

Address: 3281 E Guasti Rd  
Ontario, CA 91761, United States  
Phone: (601) 213-4426  
Email: [info@benchchem.com](mailto:info@benchchem.com)

Contact our Ph.D. Support Team for a compatibility check