

Introduction to Hydrophobic Interaction Chromatography (HIC) and the Imperative of Reproducibility

Author: BenchChem Technical Support Team. **Date:** May 2026

Compound of Interest

Compound Name: WP HI-PROPYL (C3) MEDIA

CAS No.: 126850-10-0

Cat. No.: B1176663

[Get Quote](#)

Hydrophobic Interaction Chromatography (HIC) is a powerful purification technique that separates proteins and other biomolecules based on their surface hydrophobicity. The process involves binding molecules in a high-salt mobile phase to a stationary phase with hydrophobic ligands (such as propyl groups) and eluting them by decreasing the salt concentration. This method is particularly advantageous for its ability to preserve the biological activity of the separated molecules due to the use of non-denaturing conditions.

In the context of drug development and manufacturing, particularly for biologics, reproducibility is not just a goal but a regulatory necessity. Lot-to-lot variability in chromatography media can lead to significant deviations in elution profiles, affecting purity, yield, and ultimately, the safety and efficacy of the final product. This guide provides a framework for evaluating the reproducibility of J.T. Baker's BAKERBOND Poly Hi-Propyl HIC media, along with a comparative look at other commercially available alternatives. While specific lot-to-lot data from manufacturers is often not publicly available, this guide will equip you with the methodology to conduct your own rigorous in-house validation.

Understanding BAKERBOND Poly Hi-Propyl and its Alternatives

BAKERBOND Poly Hi-Propyl is a well-established HIC medium that utilizes a propyl ligand bonded to a silica-based support. The propyl group provides a moderate level of hydrophobicity, making it suitable for a wide range of protein separations. The performance of any HIC medium is dictated by several factors including the ligand type, ligand density, and the base matrix.

When considering alternatives, it is important to look at other media with similar characteristics. The following table provides a comparison of BAKERBOND Poly Hi-Propyl with other common propyl-based HIC media.

Product	Manufacturer	Base Matrix	Ligand	Particle Size (µm)	Pore Size (Å)
BAKERBOND Poly Hi-Propyl	J.T. Baker (Avantor)	Wide-Pore Silica	Propyl	40	500
TSKgel Propyl-4PW	Tosoh Bioscience	Polymethacrylate	Propyl	20, 30	1000
Macro-Prep Propyl	Bio-Rad	Macroporous Methacrylate	Propyl	50	1000
Source 15RPC	Cytiva	Polystyrene/Divinylbenzene	Propyl	15	N/A

This table summarizes the key physical properties of these media. It is important to note that even with the same ligand, differences in the base matrix and other proprietary manufacturing processes can lead to variations in selectivity and binding capacity.

Experimental Protocol for Evaluating Lot-to-Lot Reproducibility

The following protocol provides a robust method for comparing different lots of BAKERBOND Poly Hi-Propyl or for comparing it against other HIC media. This protocol is designed to be a self-validating system.

Materials

- Chromatography columns packed with different lots of BAKERBOND Poly Hi-Propyl (or alternative media).
- A standard protein mixture (e.g., ribonuclease A, lysozyme, and myoglobin) at a known concentration.
- Mobile Phase A: 2 M ammonium sulfate in 50 mM sodium phosphate buffer, pH 7.0.
- Mobile Phase B: 50 mM sodium phosphate buffer, pH 7.0.
- HPLC or FPLC system with a UV detector.

Methodology

- Column Equilibration: Equilibrate the column with 5-10 column volumes (CVs) of Mobile Phase A until a stable baseline is achieved.
- Sample Injection: Inject a fixed volume of the standard protein mixture onto the column.
- Elution Gradient: Elute the bound proteins using a linear gradient from 100% Mobile Phase A to 100% Mobile Phase B over 20 CVs.
- Data Analysis: Monitor the elution profile at 280 nm and record the retention times and peak areas for each protein.
- Repeatability: Repeat the injection at least three times for each lot to assess the repeatability of the measurement.
- Lot-to-Lot Comparison: Compare the retention times, peak shapes, and resolution between the different lots.

Workflow for Reproducibility Testing

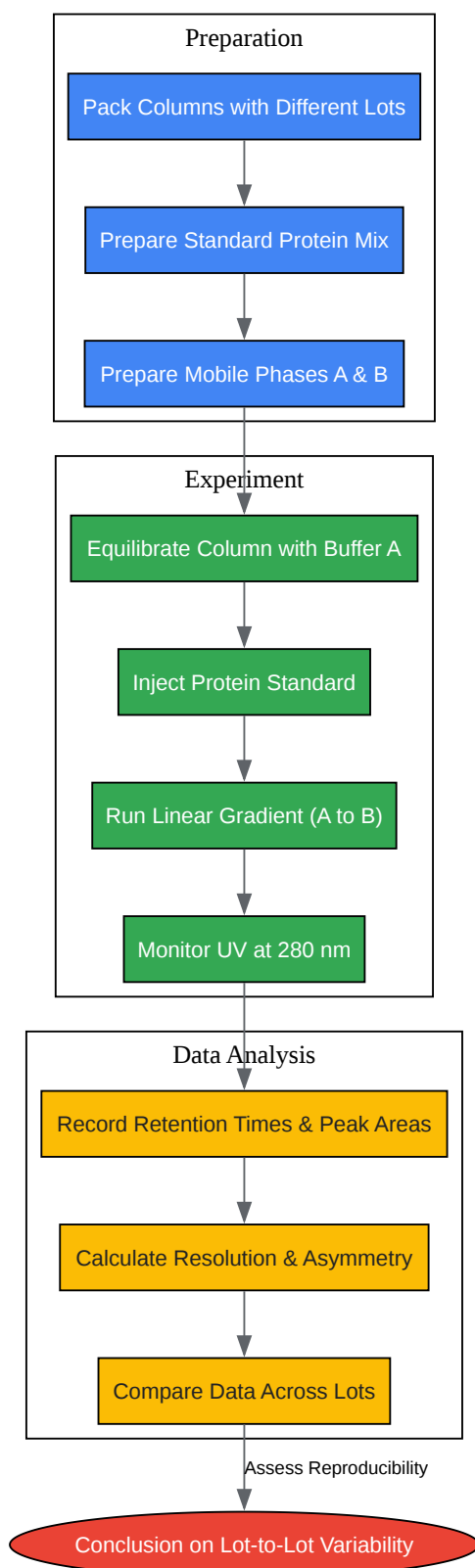

[Click to download full resolution via product page](#)

Caption: Experimental workflow for HIC lot-to-lot reproducibility testing.

Interpreting the Results and Best Practices

When analyzing the data, pay close attention to the following parameters:

- **Retention Time:** The retention times for each protein should be highly consistent between lots. A significant shift may indicate a difference in the hydrophobicity of the media.
- **Peak Shape:** The peak asymmetry factor should be close to 1. Deviations from this can indicate issues with the column packing or interactions with the stationary phase.
- **Resolution:** The resolution between adjacent peaks should be consistent. A decrease in resolution can impact the purity of the collected fractions.

To ensure the most reliable results, it is recommended to use a well-characterized and stable protein standard. Additionally, always use freshly prepared mobile phases and ensure that the chromatography system is properly maintained and calibrated.

Conclusion

While manufacturers strive for high lot-to-lot consistency, it is incumbent upon the end-user to perform their own validation, especially in a regulated environment. The protocol and framework provided in this guide offer a robust starting point for evaluating the reproducibility of BAKERBOND Poly Hi-Propyl and other HIC media. By systematically assessing key performance indicators, researchers and process scientists can ensure the consistency and reliability of their purification processes, ultimately contributing to the development of safe and effective biotherapeutics.

References

- Hydrophobic Interaction Chromatography. Bio-Rad Laboratories. [\[Link\]](#)
- Hydrophobic Interaction Chromatography (HIC) for Protein Purification. Cytiva. [\[Link\]](#)
- To cite this document: BenchChem. [\[Introduction to Hydrophobic Interaction Chromatography \(HIC\) and the Imperative of Reproducibility\]](#). BenchChem, [2026]. [\[Online PDF\]](#). Available at: [\[https://www.benchchem.com/product/b1176663/docs#introduction-to-hydrophobic-interaction-chromatography-hic-and-the-imperative-of-reproducibility\]](https://www.benchchem.com/product/b1176663/docs#introduction-to-hydrophobic-interaction-chromatography-hic-and-the-imperative-of-reproducibility)

Disclaimer & Data Validity:

The information provided in this document is for Research Use Only (RUO) and is strictly not intended for diagnostic or therapeutic procedures. While BenchChem strives to provide accurate protocols, we make no warranties, express or implied, regarding the fitness of this product for every specific experimental setup.

Technical Support: The protocols provided are for reference purposes. Unsure if this reagent suits your experiment?

Need Industrial/Bulk Grade? [Request Custom Synthesis Quote](#)

BenchChem

Our mission is to be the trusted global source of essential and advanced chemicals, empowering scientists and researchers to drive progress in science and industry.

Contact

Address: 3281 E Guasti Rd
Ontario, CA 91761, United States
Phone: (601) 213-4426
Email: info@benchchem.com

[Contact our Ph.D. Support Team for a compatibility check](#)