

A Comparative Guide to the Functional Differences of Ataxin-2 Splice Variants

Author: BenchChem Technical Support Team. **Date:** April 2026

Compound of Interest

Compound Name: *sca protein*
CAS No.: 133925-66-3
Cat. No.: B1176696

[Get Quote](#)

For Researchers, Scientists, and Drug Development Professionals

This guide provides a comprehensive comparison of ataxin-2 (ATXN2) splice variants, detailing their known functional differences with supporting experimental data. Ataxin-2 is a highly conserved RNA-binding protein implicated in several neurodegenerative diseases, including Spinocerebellar Ataxia Type 2 (SCA2) and Amyotrophic Lateral Sclerosis (ALS).^{[1][2][3]} Alternative splicing of the ATXN2 gene generates multiple protein isoforms, suggesting a complex layer of regulation for its function in cellular processes such as RNA metabolism, translation, and stress response.^{[4][5][6]} Understanding the specific roles of these variants is crucial for elucidating disease mechanisms and developing targeted therapeutics.

Ataxin-2 Protein Domain Architecture

The full-length ataxin-2 protein possesses several key functional domains that are variably affected by alternative splicing. These domains are crucial for its interactions with RNA and other proteins.^[7]

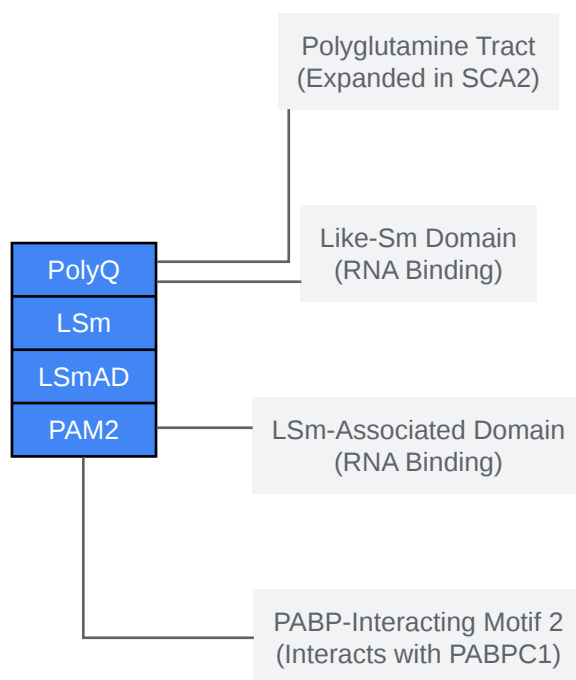

[Click to download full resolution via product page](#)

Figure 1: Domain architecture of the full-length human ataxin-2 protein.

Comparison of Known Ataxin-2 Splice Variants

Several splice variants of ataxin-2 have been identified in human and mouse tissues.[4][8]

These variants arise from the exclusion of specific exons, leading to isoforms with potentially distinct functions. The table below summarizes the key known splice variants and their characteristics.

Splice Variant	Exon(s) Lacking	Resulting Change in Protein	Known Functional Implications & Tissue Expression	References
Type I (Full-Length)	None	Contains all functional domains.	Ubiquitously expressed; involved in mRNA stability, translation, and stress granule formation. Predominant isoform in the brain and spinal cord.	[4][9]
Type II	Exon 10	Loss of a proline-rich region.	More abundant in the cerebellum than Type I. May have altered protein-protein interactions.	[4][9][10]
Type III (mouse only)	Exons 10 and 11	Loss of additional amino acid sequences.	Observed in mouse tissues; functional differences not well characterized.	[4][8]
Type IV	Exon 21	Deletion of 18 amino acids near the C-terminus.	Detected in human brain, spinal cord, cerebellum, heart, and placenta. Potential for	[8][9]

			altered C-terminal protein interactions.
Type V	Exon 12	Deletion of a segment between the LSmAD and PAM2 domains.	Identified in human cell lines, and mouse and human brain. Functional consequences are yet to be determined. [4]
Type VI	Exon 24	C-terminal truncation.	Found in human cell lines, and mouse and human brain. Likely affects protein stability and C-terminal interactions. [4]

Functional Differences: Supporting Experimental Data

While comprehensive functional comparisons of all ataxin-2 splice variants are still emerging, some studies provide insights into their differential roles.

Tissue-Specific Expression

Quantitative analysis of ataxin-2 splice variants has revealed tissue-specific expression patterns, suggesting that the relative abundance of different isoforms may contribute to tissue-specific functions.

Tissue	Relative Expression of Type I (Full-Length)	Relative Expression of Type II (Δ Exon 10)	Reference
Human Cerebellum	Lower	Higher	[10]
Human Blood	Higher	Lower	[10]

This differential expression implies that the functions of ataxin-2 may be fine-tuned in a tissue-specific manner through alternative splicing.

Key Cellular Functions and Signaling Pathways

Ataxin-2 is a central player in several interconnected cellular pathways, primarily revolving around RNA metabolism. The interplay between ataxin-2 and its binding partners dictates the fate of target mRNAs.

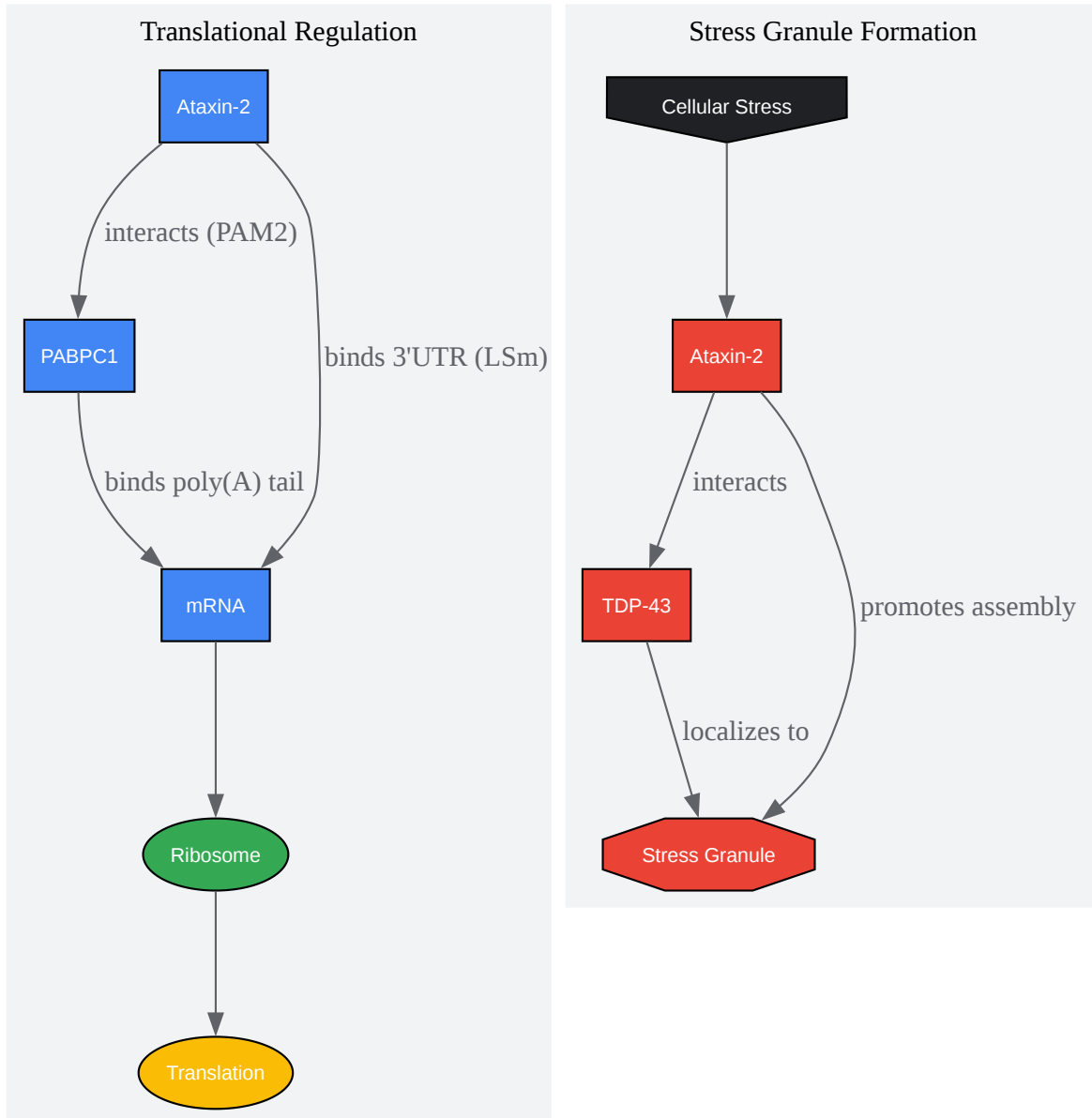

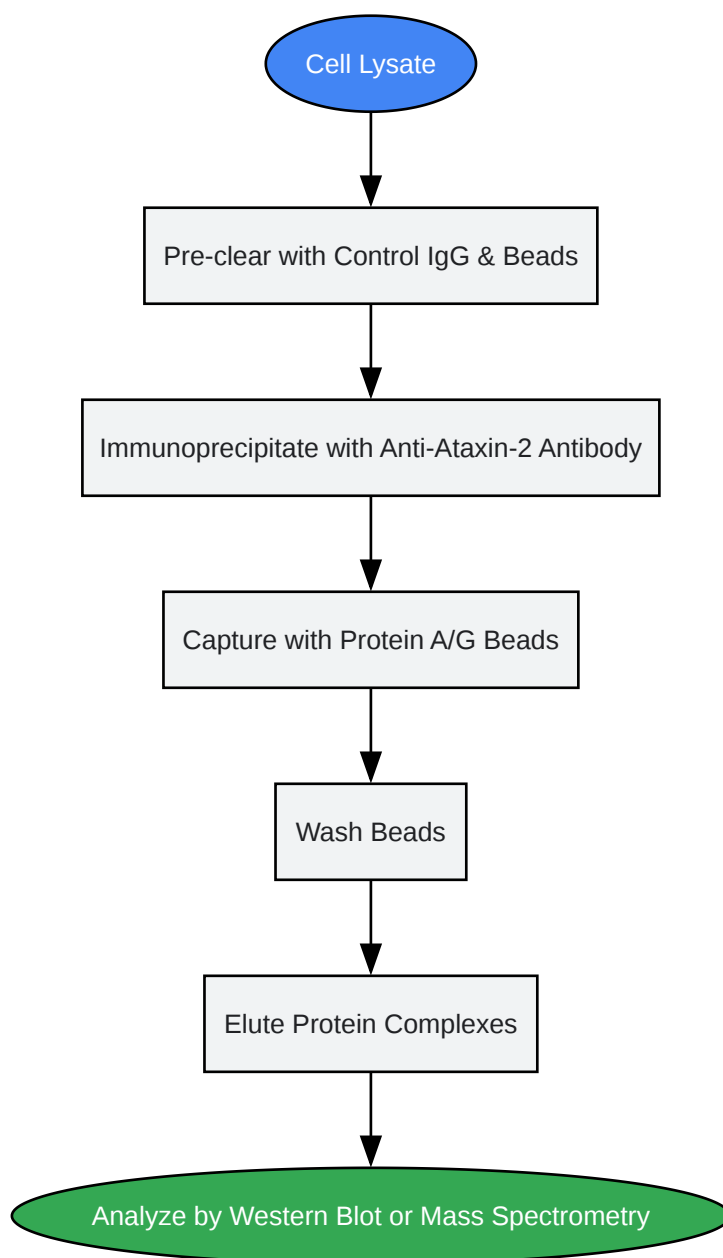

[Click to download full resolution via product page](#)

Need Custom Synthesis?

BenchChem offers custom synthesis for rare earth carbides and specific isotopic labeling.

Email: info@benchchem.com or [Request Quote Online](#).

References

- 1. New alternative splicing variants of the ATXN2 transcript - PubMed [pubmed.ncbi.nlm.nih.gov]
- 2. Ataxin-2 gene: a powerful modulator of neurological disorders - PubMed [pubmed.ncbi.nlm.nih.gov]
- 3. Ataxin-2 gene: a powerful modulator of neurological disorders - PMC [pmc.ncbi.nlm.nih.gov]
- 4. New alternative splicing variants of the ATXN2 transcript - PMC [pmc.ncbi.nlm.nih.gov]
- 5. Structural and functional analysis of ataxin-2 and ataxin-3 - PubMed [pubmed.ncbi.nlm.nih.gov]
- 6. researchgate.net [researchgate.net]
- 7. researchgate.net [researchgate.net]
- 8. Identification of alternative splicing of spinocerebellar ataxia type 2 gene - PubMed [pubmed.ncbi.nlm.nih.gov]
- 9. sinobiological.com [sinobiological.com]
- 10. researchgate.net [researchgate.net]
- To cite this document: BenchChem. [A Comparative Guide to the Functional Differences of Ataxin-2 Splice Variants]. BenchChem, [2026]. [Online PDF]. Available at: [<https://www.benchchem.com/product/b1176696/docs#a-comparative-guide-to-the-functional-differences-of-ataxin-2-splice-variants>]

Disclaimer & Data Validity:

The information provided in this document is for Research Use Only (RUO) and is strictly not intended for diagnostic or therapeutic procedures. While BenchChem strives to provide accurate protocols, we make no warranties, express or implied, regarding the fitness of this product for every specific experimental setup.

Technical Support: The protocols provided are for reference purposes. Unsure if this reagent suits your experiment?

Need Industrial/Bulk Grade? [Request Custom Synthesis Quote](#)

BenchChem

Our mission is to be the trusted global source of essential and advanced chemicals, empowering scientists and researchers to drive progress in science and industry.

Contact

Address: 3281 E Guasti Rd

Ontario, CA 91761, United States

Phone: (601) 213-4426

Email: info@benchchem.com

[Contact our Ph.D. Support Team for a compatibility check](#)