

Technical Support Center: Optimizing Nipastat Concentration for Mixed Microbial Populations

Author: BenchChem Technical Support Team. **Date:** April 2026

Compound of Interest

Compound Name:	Nipastat
CAS No.:	12765-62-7
Cat. No.:	B1175275

[Get Quote](#)

Welcome to the technical support center for optimizing **Nipastat** concentration in mixed microbial populations. This resource is designed for researchers, scientists, and drug development professionals. Here you will find troubleshooting guides and frequently asked questions (FAQs) to assist you with your experimental design and execution.

Frequently Asked Questions (FAQs)

Q1: What is **Nipastat** and what is its general mechanism of action?

Nipastat is the brand name for a preservative blend composed of a mixture of parabens, including methylparaben, ethylparaben, propylparaben, butylparaben, and isobutylparaben.[1][2][3] It is effective against a broad spectrum of microorganisms, including bacteria, molds, and yeast.[1][2] The recommended concentration in finished products is typically between 0.05% and 0.3% of the total weight.[1][2] Parabens, the active components of **Nipastat**, generally exert their antimicrobial effect by disrupting microbial cell membrane transport processes and by inhibiting the synthesis of DNA, RNA, and key enzymes.

Q2: Why is it challenging to determine the optimal **Nipastat** concentration for a mixed microbial population?

Optimizing **Nipastat** for a mixed microbial population is more complex than for a single species. Different microbial species, particularly Gram-positive and Gram-negative bacteria, exhibit varying susceptibility to antimicrobial agents due to differences in their cell wall structures.[4][5][6] Gram-negative bacteria possess an outer membrane that can act as an additional barrier, often making them more resistant.[6] In a mixed population, species can interact, potentially influencing the overall resistance of the community. Furthermore, the biofilm-forming capacity of some microbes can significantly increase resistance.

Q3: What is the Minimum Inhibitory Concentration (MIC) and why is it important?

The Minimum Inhibitory Concentration (MIC) is the lowest concentration of an antimicrobial agent that prevents the visible growth of a microorganism after a specific incubation period.[7][8][9][10] Determining the MIC is a fundamental step in assessing the effectiveness of an antimicrobial agent against a specific microbe.[7][9] For mixed populations, a modified MIC assay is necessary to determine the concentration of **Nipastat** required to inhibit the growth of all or specific targeted members of the microbial community.

Q4: How does the composition of the culture medium affect **Nipastat**'s efficacy?

The components of the culture medium can significantly impact the stability and activity of **Nipastat**. For instance, certain proteins or other organic molecules in complex media may bind to the parabens in **Nipastat**, reducing their bioavailability and antimicrobial effect. The pH of the medium is also a critical factor, as **Nipastat** is most stable in a pH range of 4 to 8.[1] It is crucial to maintain consistent and well-defined media conditions throughout your experiments to ensure reproducible results.

Troubleshooting Guide

Issue	Possible Cause(s)	Recommended Solution(s)
<p>Inconsistent MIC results between replicates.</p>	<ul style="list-style-type: none"> - Inaccurate serial dilutions. - Uneven distribution of inoculum. - Contamination of the culture. 	<ul style="list-style-type: none"> - Use calibrated pipettes and ensure thorough mixing at each dilution step. - Vortex the inoculum suspension before and during dispensing. - Use aseptic techniques and perform sterility checks on your media and reagents.
<p>No inhibition of microbial growth even at high Nipastat concentrations.</p>	<ul style="list-style-type: none"> - The microbial population contains highly resistant species. - Inactivation of Nipastat by media components. - Degradation of Nipastat due to improper storage or pH. 	<ul style="list-style-type: none"> - Perform MIC testing on individual isolates from the mixed population to identify resistant strains. - Consider using a chemically defined medium to minimize interactions. - Ensure Nipastat stock solutions are stored correctly and that the final medium pH is within the stable range (4-8).^[1]
<p>Growth of fungi or yeast but not bacteria (or vice-versa).</p>	<ul style="list-style-type: none"> - Nipastat has differential activity against different microbial kingdoms. 	<ul style="list-style-type: none"> - This is an expected outcome of selective pressure. Quantify the different populations (e.g., through selective plating or qPCR) to understand the specific effects of Nipastat on each group.
<p>Difficulty in determining the MIC for the entire mixed population.</p>	<ul style="list-style-type: none"> - Different species in the mix have widely varying susceptibilities. 	<ul style="list-style-type: none"> - Define your experimental endpoint clearly. Are you aiming to inhibit the most resistant species or achieve a certain percentage reduction in the total population? Use techniques like CFU counting on selective agar or molecular

methods to assess the impact on individual species within the mix.

Experimental Protocols and Data Presentation

Protocol: Determining the MIC of Nipastat for a Mixed Microbial Population

This protocol is adapted from standard broth microdilution methods to assess the efficacy of **Nipastat** against a mixed microbial population.

Materials:

- **Nipastat** stock solution (e.g., 10% w/v in a suitable solvent like ethanol or propylene glycol)
- Sterile 96-well microtiter plates
- Appropriate sterile liquid growth medium (e.g., Tryptic Soy Broth, Brain Heart Infusion Broth)
- Mixed microbial population inoculum, adjusted to a standardized turbidity (e.g., 0.5 McFarland standard)
- Sterile pipette tips and multichannel pipette
- Incubator

Procedure:

- Prepare Serial Dilutions:
 - Add 100 μL of sterile growth medium to all wells of a 96-well plate.
 - Add 100 μL of the **Nipastat** stock solution to the first column of wells and mix thoroughly. This will be your highest concentration.
 - Perform a 2-fold serial dilution by transferring 100 μL from the first column to the second, mixing, and continuing this process across the plate. Discard 100 μL from the last dilution

column.

- Leave one column with only medium as a sterility control and another column with medium and inoculum as a growth control.
- Inoculation:
 - Dilute the standardized microbial suspension into the growth medium to achieve a final concentration of approximately 5×10^5 CFU/mL.
 - Add 100 μ L of the diluted inoculum to all wells except the sterility control.
- Incubation:
 - Cover the plate and incubate at the optimal temperature for the microbial population (e.g., 37°C) for 18-24 hours.
- Determining the MIC:
 - After incubation, visually inspect the wells for turbidity. The MIC is the lowest concentration of **Nipastat** in which no visible growth is observed.^[9]
 - To quantify the effect on different species, plate a small aliquot from each well onto various selective and differential agar plates. Count the colonies after incubation to determine the CFU/mL for each species at each **Nipastat** concentration.

Data Presentation: Example MIC Values

The following table summarizes hypothetical MIC data for **Nipastat** against individual bacterial species and a mixed population.

Microorganism	Gram Stain	Hypothetical MIC of Nipastat (% w/v)
Staphylococcus aureus	Positive	0.08
Bacillus subtilis	Positive	0.06
Escherichia coli	Negative	0.15
Pseudomonas aeruginosa	Negative	0.20
Mixed Population (all four species)	N/A	0.25*

*This value represents the concentration needed to inhibit the visible growth of the entire mixed population, which is dictated by the most resistant member (*P. aeruginosa* in this hypothetical case).

Visualizations

Diagram: Experimental Workflow for MIC Determination

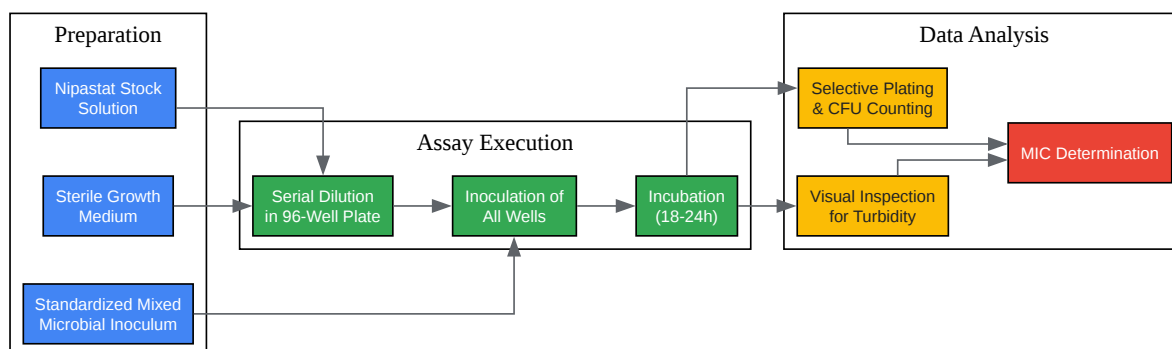

[Click to download full resolution via product page](#)

Caption: Workflow for determining the Minimum Inhibitory Concentration (MIC) of **Nipastat**.

Diagram: Generalized Mechanism of Action of Parabens

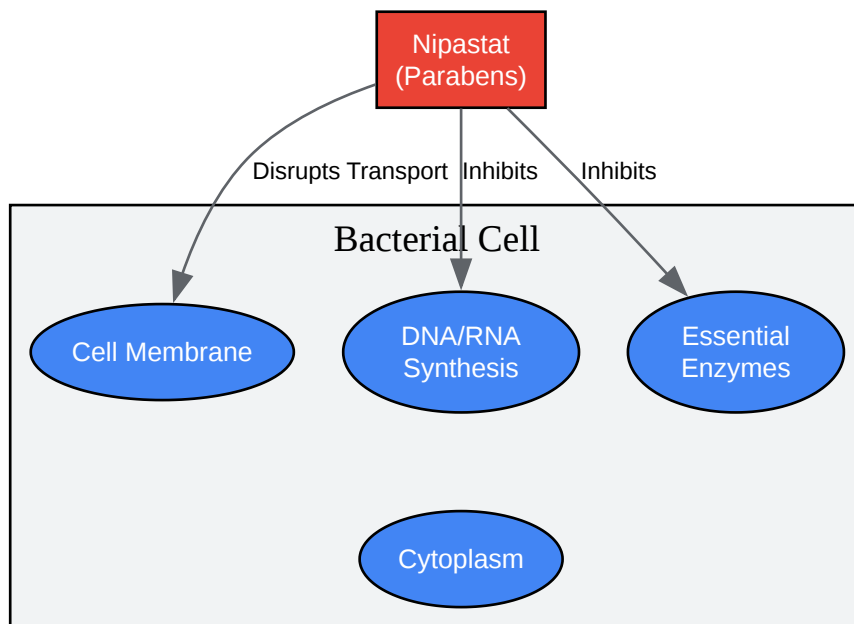

[Click to download full resolution via product page](#)

Caption: Generalized antimicrobial mechanism of action for parabens (**Nipastat**).

Need Custom Synthesis?

BenchChem offers custom synthesis for rare earth carbides and specific isotopic labeling.

Email: info@benchchem.com or [Request Quote Online](#).

References

- 1. Nipastat - Wikipedia [en.wikipedia.org]
- 2. ulprospector.com [ulprospector.com]
- 3. specialchem.com [specialchem.com]
- 4. blog.eoscu.com [blog.eoscu.com]
- 5. Gram Positive vs Gram Negative Bacteria Explained | Technology Networks [technologynetworks.com]
- 6. Gram Positive vs Gram Negative Bacteria | ORAPI Asia [orapiasia.com]

- [7. emerypharma.com \[emerypharma.com\]](https://www.emerypharma.com)
- [8. biotechnologiebt.it \[biotechnologiebt.it\]](https://www.biotechnologiebt.it)
- [9. microbe-investigations.com \[microbe-investigations.com\]](https://www.microbe-investigations.com)
- [10. bmglabtech.com \[bmglabtech.com\]](https://www.bmglabtech.com)
- To cite this document: BenchChem. [Technical Support Center: Optimizing Nipastat Concentration for Mixed Microbial Populations]. BenchChem, [2026]. [Online PDF]. Available at: [<https://www.benchchem.com/product/b1175275/docs#technical-support-center-optimizing-nipastat-concentration-for-mixed-microbial-populations>]

Disclaimer & Data Validity:

The information provided in this document is for Research Use Only (RUO) and is strictly not intended for diagnostic or therapeutic procedures. While BenchChem strives to provide accurate protocols, we make no warranties, express or implied, regarding the fitness of this product for every specific experimental setup.

Technical Support: The protocols provided are for reference purposes. Unsure if this reagent suits your experiment?

Need Industrial/Bulk Grade? [Request Custom Synthesis Quote](#)

BenchChem

Our mission is to be the trusted global source of essential and advanced chemicals, empowering scientists and researchers to drive progress in science and industry.

Contact

Address: 3281 E Guasti Rd
Ontario, CA 91761, United States
Phone: (601) 213-4426
Email: info@benchchem.com

[Contact our Ph.D. Support Team for a compatibility check](#)

