

GRB10 Protein-Protein Interaction Network: An In-depth Technical Guide

Author: BenchChem Technical Support Team. **Date:** May 2026

Compound of Interest

Compound Name: *growth factor receptor-bound protein 10*

CAS No.: *151441-47-3*

Cat. No.: *B1174771*

[Get Quote](#)

For Researchers, Scientists, and Drug Development Professionals

Abstract

Growth factor receptor-bound protein 10 (GRB10) is a pivotal adaptor protein implicated in a multitude of cellular processes, including growth, metabolism, and apoptosis.[1] Its intricate network of protein-protein interactions, primarily mediated through its distinct functional domains, positions it as a critical regulator of key signaling pathways, most notably the insulin/IGF-1 and mTORC1 pathways. Dysregulation of GRB10 interactions has been linked to various pathological conditions, including metabolic disorders and cancer, making it an attractive target for therapeutic intervention. This technical guide provides a comprehensive overview of the GRB10 protein-protein interaction network, detailing its key interacting partners, the signaling pathways it modulates, and the experimental methodologies used to elucidate these connections.

GRB10 Protein Domain Architecture and Interacting Partners

GRB10 is a multidomain adaptor protein, lacking any intrinsic enzymatic activity. Its function is to physically link various proteins, thereby modulating signal transduction. The primary domains of GRB10 and their key interacting partners are summarized below.

GRB10 Domain	Interacting Partners	Interaction Details and Significance
SH2 (Src Homology 2) Domain	Insulin Receptor (IR), Insulin-like Growth Factor 1 Receptor (IGF1R), Epidermal Growth Factor Receptor (EGFR), Platelet-Derived Growth Factor Receptor (PDGFR), Fibroblast Growth Factor Receptor (FGFR), c-Kit, RET, MET, FLT3, VEGFR-2, RAF1, MEK1, NEDD4	The SH2 domain is crucial for GRB10's interaction with phosphorylated tyrosine residues on activated receptor tyrosine kinases (RTKs) and other signaling proteins.[1][2] It plays a significant role in mediating GRB10's inhibitory effects on insulin and IGF-1 signaling.[1][3] The interaction with the E3 ubiquitin ligase NEDD4, which is phosphotyrosine-independent, facilitates the ubiquitination and degradation of IGF1R.[4] [5] The GRB10 SH2 domain can also interact with the kinases RAF1 and MEK1 in a phosphotyrosine-independent manner.
BPS (Between PH and SH2) Domain	Insulin Receptor (IR), Insulin-like Growth Factor 1 Receptor (IGF1R)	This domain, unique to the GRB7/10/14 family, works in concert with the SH2 domain to mediate high-affinity binding to the insulin and IGF-1 receptors.[6][7] The BPS domain of GRB10 has been shown to directly inhibit the catalytic activity of the IR and IGF1R.[1]
PH (Pleckstrin Homology) Domain	Phosphoinositides	This domain is involved in targeting GRB10 to the plasma membrane through its

interaction with phosphoinositides.

PR (Proline-Rich) Domain

GIGYF1/2 (GRB10 Interacting GYF domain proteins 1 and 2)

The N-terminal proline-rich region of GRB10 interacts with GIGYF1 and GIGYF2, which are thought to modulate insulin signaling.[1][8]

Quantitative Analysis of GRB10 Interactions

Quantifying the binding affinities of protein-protein interactions is crucial for understanding the dynamics of signaling networks. However, for many GRB10 interactions, precise dissociation constants (Kd) are not readily available in the published literature. The table below summarizes the available quantitative and qualitative data.

GRB10 Interacting Partner	Method	Binding Affinity (Kd) / Notes
Insulin Receptor (IR)	Surface Plasmon Resonance (SPR)	<p>While a direct Kd for the GRB10-IR interaction is not specified, studies indicate a high-affinity interaction mediated by both the SH2 and BPS domains.[7] For comparison, the insulin-insulin receptor interaction exhibits a two-site binding pattern with a high-affinity Kd of 38.1 ± 0.9 nM and a low-affinity Kd of 166.3 ± 7.3 nM.[9]</p>
IGF-1 Receptor (IGF1R)	Yeast Two-Hybrid, Co-IP	<p>The interaction is well-established, but specific quantitative data on binding affinity is lacking.</p>
NEDD4	Yeast Two-Hybrid, Co-IP	<p>The interaction between the GRB10 SH2 domain and the NEDD4 C2 domain is described as strong, but a Kd value has not been reported. [1] This interaction is notably phosphotyrosine-independent. [1][5]</p>
RAF1	Yeast Two-Hybrid, Co-IP	<p>Interaction is constitutive and phosphotyrosine-independent. Quantitative affinity data is not available.</p>

MEK1	Yeast Two-Hybrid, Co-IP	Interaction is insulin-dependent and phosphotyrosine-independent. Quantitative affinity data is not available.
GIGYF1/2	Yeast Two-Hybrid	Interaction is mediated by the GRB10 PR domain. Binding constants have not been reported.

GRB10 in Signaling Pathways

GRB10 is a key regulator of several critical signaling pathways, often acting as a negative feedback inhibitor.

Insulin/IGF-1 Signaling Pathway

GRB10 is a well-established negative regulator of the insulin and IGF-1 signaling pathways.[1][3] Upon insulin or IGF-1 stimulation, the respective receptors (IR/IGF1R) undergo autophosphorylation on tyrosine residues. GRB10 is then recruited to the activated receptor via its SH2 and BPS domains.[1][7] This interaction sterically hinders the binding of downstream signaling molecules, such as Insulin Receptor Substrate (IRS) proteins, and also directly inhibits the kinase activity of the receptor.[1] Furthermore, by recruiting the E3 ubiquitin ligase NEDD4, GRB10 promotes the ubiquitination and subsequent degradation of the IGF1R.[4][5]

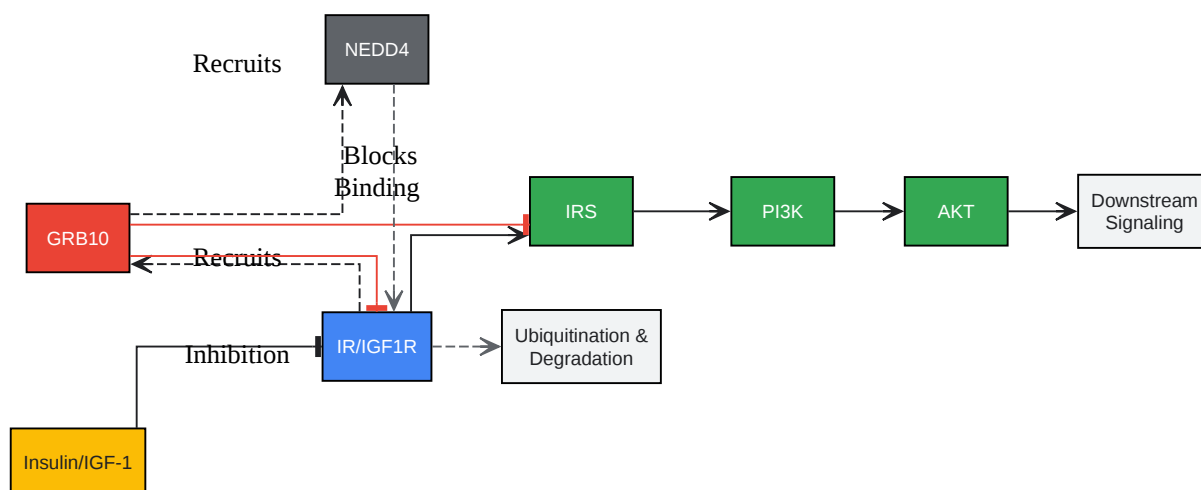

[Click to download full resolution via product page](#)

GRB10 in Insulin/IGF-1 Signaling

mTORC1 Signaling Pathway

GRB10 is a direct substrate of the mammalian target of rapamycin complex 1 (mTORC1).[10] Phosphorylation of GRB10 by mTORC1 stabilizes the protein and enhances its inhibitory effect on the PI3K/Akt pathway, forming a negative feedback loop.[11] This intricate relationship highlights GRB10's role in integrating nutrient and growth factor signaling.

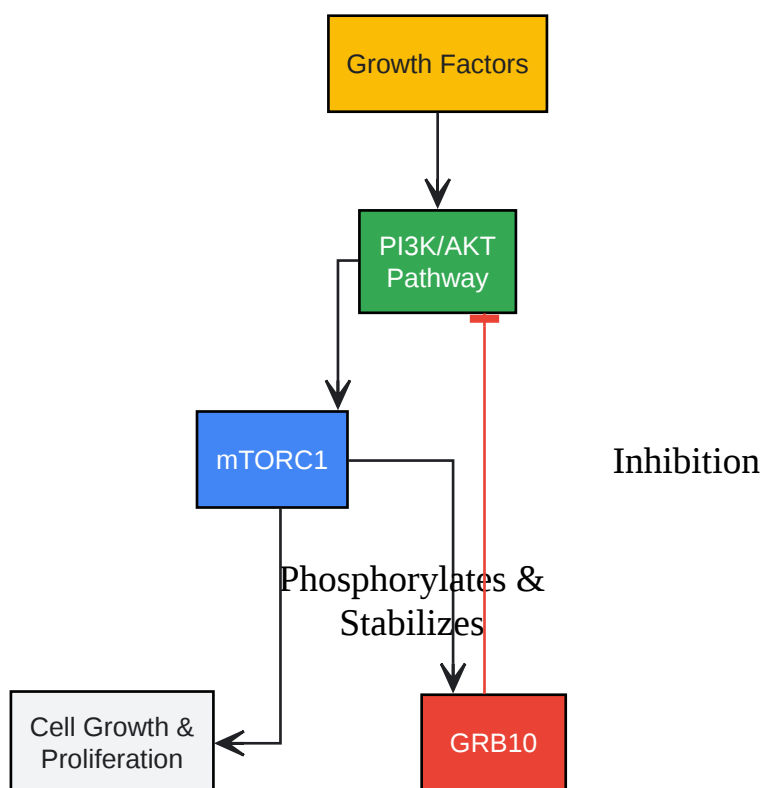

[Click to download full resolution via product page](#)

GRB10 in mTORC1 Signaling

Experimental Protocols

The identification and characterization of GRB10 protein-protein interactions have been achieved through a variety of experimental techniques. Detailed protocols for three key methods are provided below.

Co-Immunoprecipitation (Co-IP) to Detect GRB10 Interactions

Objective: To isolate GRB10 and its interacting partners from a cell lysate.

Materials:

- Cells expressing endogenous or tagged GRB10.

- Lysis buffer (e.g., RIPA buffer: 50 mM Tris-HCl pH 7.4, 150 mM NaCl, 1% NP-40, 0.5% sodium deoxycholate, 0.1% SDS, supplemented with protease and phosphatase inhibitors).
- Anti-GRB10 antibody or antibody against the tag.
- Protein A/G magnetic beads or agarose beads.
- Wash buffer (e.g., lysis buffer with lower detergent concentration).
- Elution buffer (e.g., 2x Laemmli sample buffer).
- SDS-PAGE and Western blotting reagents.

Procedure:

- Cell Lysis:
 - Wash cultured cells with ice-cold PBS.
 - Add ice-cold lysis buffer and incubate on ice for 30 minutes with occasional vortexing.
 - Centrifuge at 14,000 x g for 15 minutes at 4°C to pellet cell debris.
 - Transfer the supernatant (cell lysate) to a pre-chilled tube.
- Pre-clearing the Lysate (Optional but Recommended):
 - Add protein A/G beads to the cell lysate and incubate with rotation for 1 hour at 4°C to reduce non-specific binding.
 - Centrifuge to pellet the beads and transfer the supernatant to a new tube.
- Immunoprecipitation:
 - Add the primary antibody (e.g., anti-GRB10) to the pre-cleared lysate and incubate with rotation for 2-4 hours or overnight at 4°C.
 - Add protein A/G beads and incubate for an additional 1-2 hours at 4°C with rotation.

- Washing:
 - Pellet the beads by centrifugation and discard the supernatant.
 - Wash the beads 3-5 times with ice-cold wash buffer. After the final wash, carefully remove all supernatant.
- Elution:
 - Resuspend the beads in elution buffer.
 - Boil the samples at 95-100°C for 5-10 minutes to dissociate the protein complexes from the beads and antibody.
 - Centrifuge to pellet the beads and collect the supernatant containing the eluted proteins.
- Analysis:
 - Analyze the eluted proteins by SDS-PAGE and Western blotting using antibodies against GRB10 and its suspected interacting partners.

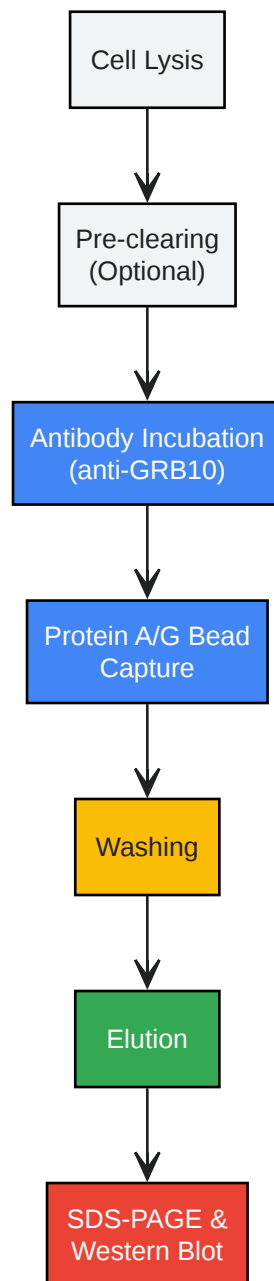

[Click to download full resolution via product page](#)

Co-Immunoprecipitation Workflow

Yeast Two-Hybrid (Y2H) Screening

Objective: To identify novel GRB10 interacting proteins from a cDNA library.

Principle: The Y2H system is based on the modular nature of transcription factors, which have a DNA-binding domain (BD) and a transcriptional activation domain (AD). In this system,

GRB10 (the "bait") is fused to the BD, and a library of potential interacting proteins (the "prey") is fused to the AD. If the bait and prey interact, the BD and AD are brought into proximity, reconstituting a functional transcription factor that drives the expression of reporter genes.

Materials:

- Yeast strains (e.g., AH109, Y187).
- Bait plasmid (e.g., pGBKT7) containing the GRB10 cDNA.
- Prey cDNA library in a suitable vector (e.g., pGADT7).
- Yeast transformation reagents (e.g., lithium acetate, polyethylene glycol).
- Appropriate selective media (e.g., SD/-Trp, SD/-Leu, SD/-Trp/-Leu, SD/-Trp/-Leu/-His/-Ade).
- Reagents for β -galactosidase assay (e.g., X-gal).

Procedure:

- Bait Plasmid Construction and Validation:
 - Clone the GRB10 cDNA in-frame with the DNA-binding domain in the bait vector.
 - Transform the bait plasmid into a suitable yeast strain.
 - Confirm that the bait protein is expressed and does not auto-activate the reporter genes.
- Library Screening by Mating:
 - Transform the prey library into a yeast strain of the opposite mating type.
 - Mate the bait-expressing yeast strain with the prey library-expressing strain.
 - Plate the diploid yeast on selective media lacking tryptophan and leucine to select for cells containing both bait and prey plasmids.
- Selection of Positive Interactions:

- Replica-plate the diploid yeast onto high-stringency selective media (e.g., SD/-Trp/-Leu/-His/-Ade) to select for interacting proteins.
- Perform a β -galactosidase filter lift assay to further confirm positive interactions.
- Prey Plasmid Rescue and Identification:
 - Isolate the prey plasmids from the positive yeast colonies.
 - Transform the rescued prey plasmids into E. coli for amplification.
 - Sequence the cDNA insert of the prey plasmids to identify the interacting proteins.
- Validation of Interactions:
 - Re-transform the identified prey plasmid with the original bait plasmid into yeast to confirm the interaction.
 - Perform additional assays (e.g., Co-IP) to validate the interaction in a different system.

GST Pull-Down Assay

Objective: To confirm a direct interaction between GRB10 and a putative binding partner in vitro.

Materials:

- Expression vectors for GST-tagged GRB10 and the prey protein (e.g., with a His-tag or other tag for detection).
- E. coli expression strain (e.g., BL21).
- Glutathione-agarose or magnetic beads.
- Lysis buffer for bacteria (e.g., PBS with 1% Triton X-100 and protease inhibitors).
- Binding/Wash buffer (e.g., PBS with 0.1% Triton X-100).
- Elution buffer (e.g., 10-50 mM reduced glutathione in 50 mM Tris-HCl, pH 8.0).

Procedure:

- Protein Expression and Purification:
 - Express GST-GRB10 and the prey protein in E. coli.
 - Lyse the bacteria and purify the GST-GRB10 protein using glutathione beads.
 - Purify the prey protein using an appropriate method based on its tag.
- GST Pull-Down:
 - Incubate the purified GST-GRB10 bound to glutathione beads with the purified prey protein in binding buffer for 1-4 hours at 4°C.
 - As a negative control, incubate the prey protein with GST alone bound to beads.
- Washing:
 - Wash the beads 3-5 times with wash buffer to remove non-specifically bound proteins.
- Elution:
 - Elute the GST-GRB10 and any interacting prey protein from the beads using elution buffer.
- Analysis:
 - Analyze the eluted fractions by SDS-PAGE and Coomassie blue staining or Western blotting using an antibody against the prey protein's tag.

Conclusion and Future Directions

The GRB10 protein-protein interaction network is a complex and dynamic system that plays a crucial role in cellular signaling. While significant progress has been made in identifying the key players and their connections, a comprehensive quantitative understanding of these interactions is still emerging. Future research should focus on determining the binding affinities and kinetics of GRB10 with its various partners under different cellular conditions. Such data will be invaluable for developing sophisticated models of GRB10-mediated signaling and for

designing targeted therapeutics for diseases where this network is dysregulated. The continued application of advanced techniques such as surface plasmon resonance, isothermal titration calorimetry, and quantitative mass spectrometry will be instrumental in achieving this goal.

Need Custom Synthesis?

BenchChem offers custom synthesis for rare earth carbides and specific isotopic labeling.

Email: info@benchchem.com or [Request Quote Online](#).

References

- 1. The BPS domain of Grb10 inhibits the catalytic activity of the insulin and IGF1 receptors - PubMed [pubmed.ncbi.nlm.nih.gov]
- 2. Grb10 and Grb14: enigmatic regulators of insulin action--and more? - PubMed [pubmed.ncbi.nlm.nih.gov]
- 3. The Grb10/Nedd4 Complex Regulates Ligand-Induced Ubiquitination and Stability of the Insulin-Like Growth Factor I Receptor - PMC [pmc.ncbi.nlm.nih.gov]
- 4. assaygenie.com [assaygenie.com]
- 5. cube-biotech.com [cube-biotech.com]
- 6. researchgate.net [researchgate.net]
- 7. The cloning of Grb10 reveals a new family of SH2 domain proteins - PubMed [pubmed.ncbi.nlm.nih.gov]
- 8. escholarship.mcgill.ca [escholarship.mcgill.ca]
- 9. Insulin receptor-insulin interaction kinetics using multiplex surface plasmon resonance - PubMed [pubmed.ncbi.nlm.nih.gov]
- 10. goldbio.com [goldbio.com]
- 11. Grb10 and Grb14: enigmatic regulators of insulin action – and more? - PMC [pmc.ncbi.nlm.nih.gov]
- To cite this document: BenchChem. [GRB10 Protein-Protein Interaction Network: An In-depth Technical Guide]. BenchChem, [2026]. [Online PDF]. Available at: [<https://www.benchchem.com/product/b1174771/docs#grb10-protein-protein-interaction-network-an-in-depth-technical-guide>]

Disclaimer & Data Validity:

The information provided in this document is for Research Use Only (RUO) and is strictly not intended for diagnostic or therapeutic procedures. While BenchChem strives to provide accurate protocols, we make no warranties, express or implied, regarding the fitness of this product for every specific experimental setup.

Technical Support: The protocols provided are for reference purposes. Unsure if this reagent suits your experiment?

Need Industrial/Bulk Grade? [Request Custom Synthesis Quote](#)

BenchChem

Our mission is to be the trusted global source of essential and advanced chemicals, empowering scientists and researchers to drive progress in science and industry.

Contact

Address: 3281 E Guasti Rd
Ontario, CA 91761, United States
Phone: (601) 213-4426
Email: info@benchchem.com

[Contact our Ph.D. Support Team for a compatibility check](#)