

# Application Notes and Protocols: Validating GRB10 Interactions Using Proximity Ligation Assay

**Author:** BenchChem Technical Support Team. **Date:** May 2026

## Compound of Interest

Compound Name:	<i>growth factor receptor-bound protein 10</i>
CAS No.:	151441-47-3
Cat. No.:	B1174771

[Get Quote](#)

For Researchers, Scientists, and Drug Development Professionals

## Introduction

**Growth factor receptor-bound protein 10 (GRB10)** is a crucial adapter protein involved in multiple signaling pathways, most notably the insulin/IGF-1 and mTORC1 pathways.[1][2] Its function as a modulator of signal transduction makes it a protein of significant interest in metabolic diseases and oncology.[2][3] Validating the protein-protein interactions of GRB10 is essential for understanding its cellular function and for the development of targeted therapeutics. The Proximity Ligation Assay (PLA) is a highly sensitive and specific method for the in situ detection of protein-protein interactions.[4][5] This technique allows for the visualization and quantification of interactions at the single-molecule level within the native cellular context.[5][6]

These application notes provide a detailed protocol for utilizing PLA to validate and quantify GRB10 interactions, present data on known interactions, and illustrate the signaling pathways

in which GRB10 plays a pivotal role.

## Data Presentation

### Quantitative Analysis of GRB10-GIGYF2 Interaction by PLA

The following table summarizes quantitative data from a study investigating the interaction between GRB10 and GIGYF2 (GRB10-interacting GYF protein 2) using a proximity ligation assay.[7][8] The results indicate a lack of significant interaction between the human versions of these proteins.

Interacting Proteins	Cell Line	Experimental Condition	Mean PLA Signals per Cell ( $\pm$ SEM)	Conclusion of Interaction
FLAG-GRB10 & v5-IGF-1R	HEK293T	Co-transfection (Positive Control)	~45	Strong Interaction
FLAG-GRB10 & v5-Empty	HEK293T	Co-transfection (Negative Control)	~5	No Significant Interaction
FLAG-GRB10 & v5-GIGYF2	HEK293T	Co-transfection	~5	No Significant Interaction

### Known and Potential GRB10 Interaction Partners for PLA Validation

GRB10 is known to interact with a variety of proteins through different domains. While many of these interactions have been identified using methods like co-immunoprecipitation, PLA offers a powerful tool for in situ validation and quantification. The table below lists key interacting partners of GRB10.

Interacting Partner	GRB10 Domain Involved	Method of Identification	Potential for PLA Validation
Insulin Receptor (IR)	SH2 and BPS domains	Co-IP, Yeast-two-hybrid	High
IGF-1 Receptor (IGF-1R)	SH2 and BPS domains	Co-IP, Yeast-two-hybrid	High
mTORC1 (via Raptor)	Phosphorylation-dependent	Co-IP	High
Nedd4	SH2 domain	Yeast-two-hybrid, Co-IP	High
Raf-1	SH2 domain	Co-IP, Yeast-two-hybrid	High
MEK1	SH2 domain	Yeast-two-hybrid	High
GIGYF2	Proline-rich domain (in mouse)	Yeast-two-hybrid	Species-dependent
RET	SH2 domain	Co-IP	High
KIT	SH2 domain	Yeast-two-hybrid	High
MET	SH2 domain	Co-IP	High
PDGFR	SH2 domain	Co-IP	High
EGFR	SH2 domain	Co-IP	Moderate
FLT3	SH2 domain	Co-IP	High
VEGFR-2	SH2 domain	Co-IP	High

## Experimental Protocols

### Proximity Ligation Assay for GRB10 Interaction Validation

This protocol is adapted from standard Duolink® PLA protocols and is suitable for validating the interaction between GRB10 and a protein of interest (POI) in cultured cells.

#### Materials:

- Cells: Adherent cells cultured on sterile glass coverslips in a multi-well plate.
- Primary Antibodies: Two primary antibodies raised in different species (e.g., rabbit anti-GRB10 and mouse anti-POI).
- Duolink® In Situ PLA® Probes: Anti-Rabbit PLUS and Anti-Mouse MINUS.
- Duolink® In Situ Detection Reagents: (e.g., Red, Orange, or Green).
- Duolink® In Situ Wash Buffers A and B.
- Duolink® In Situ Antibody Diluent.
- Duolink® In Situ Mounting Medium with DAPI.
- Fixation Solution: 4% Paraformaldehyde (PFA) in PBS.
- Permeabilization Solution: 0.1% Triton X-100 in PBS.
- Blocking Solution: Provided with the Duolink® kit or 3% BSA in PBS.
- Humidity Chamber.
- Fluorescence Microscope.

#### Procedure:

- Cell Culture and Treatment:
  - Seed cells on sterile coverslips in a multi-well plate and culture to desired confluency.
  - If studying interaction under specific conditions, treat the cells with appropriate stimuli (e.g., insulin, IGF-1) or inhibitors.

- Fixation and Permeabilization:
  - Aspirate the culture medium and wash the cells twice with PBS.
  - Fix the cells with 4% PFA for 15 minutes at room temperature.
  - Wash twice with PBS.
  - Permeabilize the cells with 0.1% Triton X-100 in PBS for 10 minutes at room temperature.
  - Wash twice with PBS.
- Blocking:
  - Add Duolink® Blocking Solution to each coverslip and incubate in a humidity chamber for 1 hour at 37°C.
- Primary Antibody Incubation:
  - Dilute the primary antibodies (rabbit anti-GRB10 and mouse anti-POI) in Duolink® Antibody Diluent to their optimal concentrations (determined by immunofluorescence titration).
  - Tap off the blocking solution and add the primary antibody mixture.
  - Incubate in a humidity chamber overnight at 4°C.
- PLA Probe Incubation:
  - Wash the coverslips twice for 5 minutes each with Wash Buffer A.
  - Dilute the PLA probes (Anti-Rabbit PLUS and Anti-Mouse MINUS) 1:5 in Antibody Diluent.
  - Add the PLA probe mixture to the coverslips.
  - Incubate in a humidity chamber for 1 hour at 37°C.
- Ligation:

- Wash the coverslips twice for 5 minutes each with Wash Buffer A.
- Prepare the ligation solution by diluting the Ligation Buffer 1:5 in high-purity water and then adding Ligase at a 1:40 dilution.
- Add the ligation solution to the coverslips.
- Incubate in a humidity chamber for 30 minutes at 37°C.
- Amplification:
  - Wash the coverslips twice for 5 minutes each with Wash Buffer A.
  - Prepare the amplification solution by diluting the Amplification Buffer 1:5 in high-purity water and then adding Polymerase at a 1:80 dilution.
  - Add the amplification solution to the coverslips.
  - Incubate in a humidity chamber for 100 minutes at 37°C.
- Final Washes and Mounting:
  - Wash the coverslips twice for 10 minutes each with Wash Buffer B.
  - Briefly rinse with 0.01x Wash Buffer B.
  - Mount the coverslips on a glass slide using Duolink® In Situ Mounting Medium with DAPI.
- Imaging and Analysis:
  - Image the slides using a fluorescence microscope.
  - Quantify the PLA signals (dots) per cell using image analysis software (e.g., ImageJ/Fiji with the BlobFinder plugin). The number of dots per cell is a quantitative measure of the protein-protein interaction.<sup>[4][9]</sup>

## Visualizations

### GRB10 Signaling Pathways

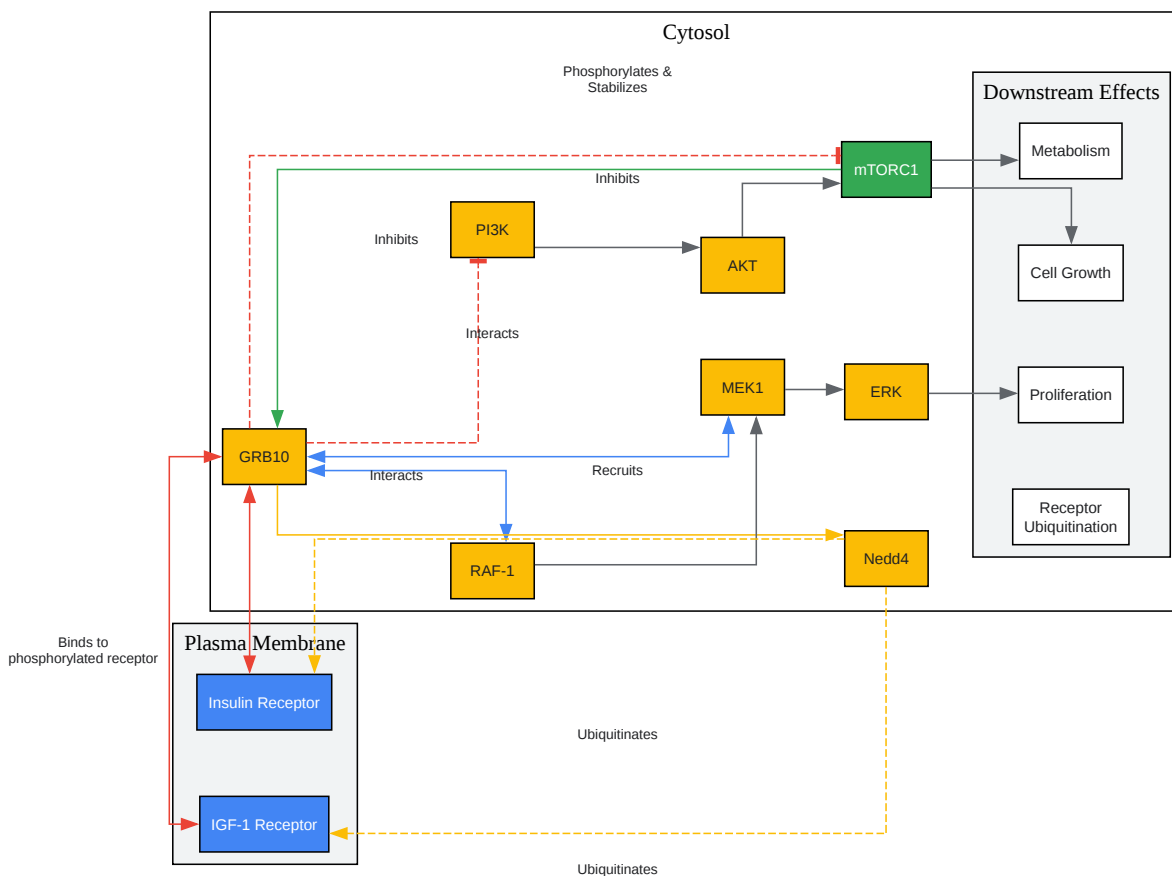

[Click to download full resolution via product page](#)

Caption: GRB10 signaling network.

## Proximity Ligation Assay (PLA) Experimental Workflow

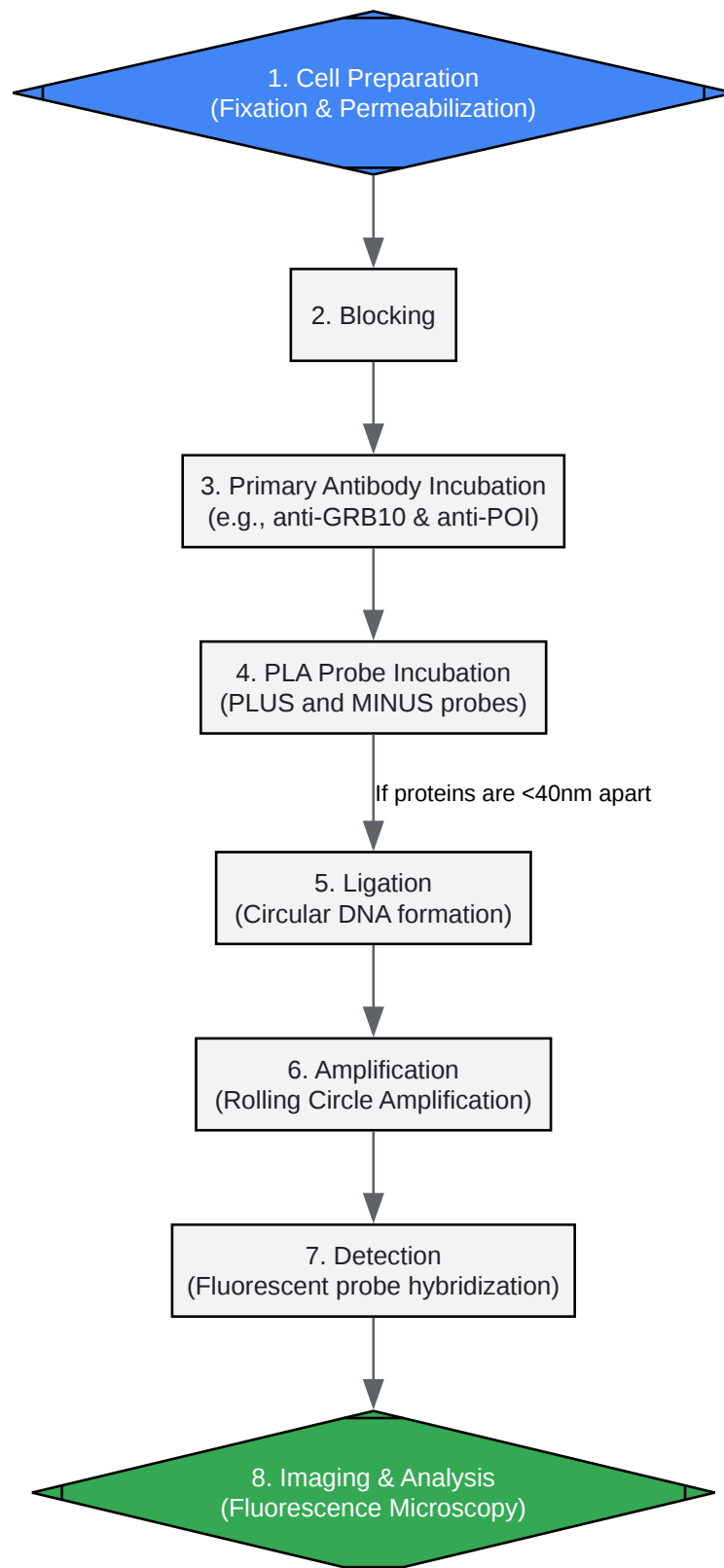

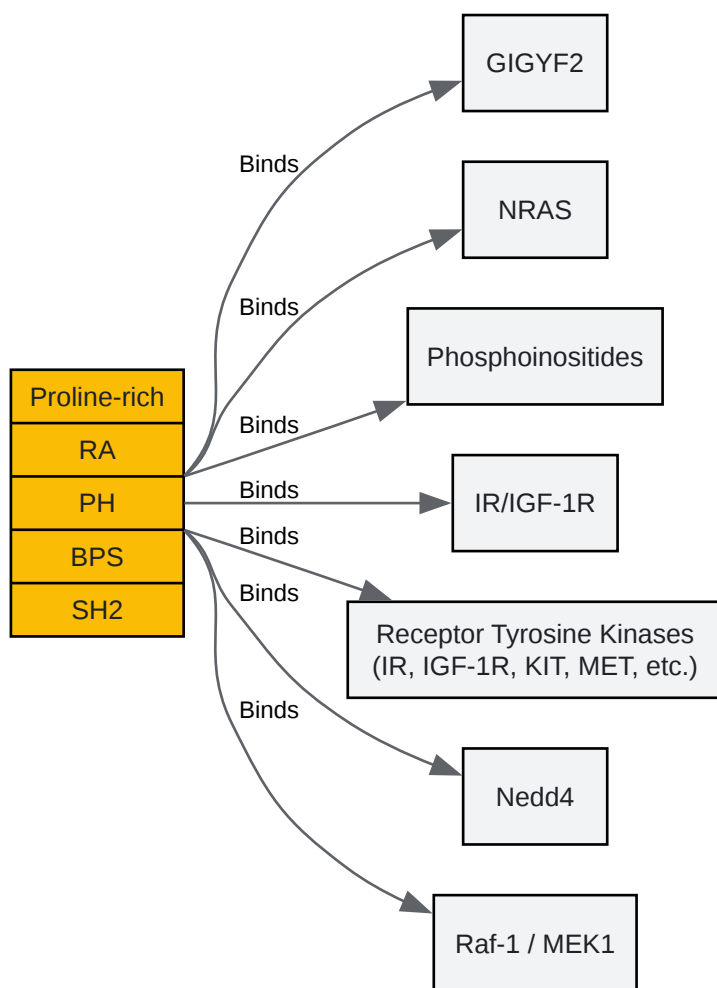

[Click to download full resolution via product page](#)

### Need Custom Synthesis?

BenchChem offers custom synthesis for rare earth carbides and specific isotopic labeling.

Email: [info@benchchem.com](mailto:info@benchchem.com) or [Request Quote Online](#).

## References

- 1. Mice with a Disruption of the Imprinted Grb10 Gene Exhibit Altered Body Composition, Glucose Homeostasis, and Insulin Signaling during Postnatal Life - PMC [[pmc.ncbi.nlm.nih.gov](https://pubmed.ncbi.nlm.nih.gov/16111111/)]
- 2. GRB10 regulates  $\beta$ -cell mass by inhibiting  $\beta$ -cell proliferation and stimulating  $\beta$ -cell dedifferentiation - PubMed [[pubmed.ncbi.nlm.nih.gov](https://pubmed.ncbi.nlm.nih.gov/16111111/)]

- 3. FLT3 signals via the adapter protein Grb10 and overexpression of Grb10 leads to aberrant cell proliferation in acute myeloid leukemia - PMC [[pmc.ncbi.nlm.nih.gov](https://pubmed.ncbi.nlm.nih.gov/)]
- 4. Proximity Ligation Assay for Detecting Protein-Protein Interactions and Protein Modifications in Cells and Tissues In Situ - PMC [[pmc.ncbi.nlm.nih.gov](https://pubmed.ncbi.nlm.nih.gov/)]
- 5. Protein-protein Interactions Detection with PLA [[sigmaaldrich.com](https://sigmaaldrich.com/)]
- 6. Quantification of protein expression by proximity ligation assay in the nonhuman primate in response to estrogen - PMC [[pmc.ncbi.nlm.nih.gov](https://pubmed.ncbi.nlm.nih.gov/)]
- 7. No evidence that human GIGYF2 interacts with GRB10: implications for human disease | Life Science Alliance [[life-science-alliance.org](https://life-science-alliance.org/)]
- 8. [researchgate.net](https://researchgate.net/) [[researchgate.net](https://researchgate.net/)]
- 9. Quantitative in situ proximity ligation assays examining protein interactions and phosphorylation during smooth muscle contractions - PMC [[pmc.ncbi.nlm.nih.gov](https://pubmed.ncbi.nlm.nih.gov/)]
- To cite this document: BenchChem. [Application Notes and Protocols: Validating GRB10 Interactions Using Proximity Ligation Assay]. BenchChem, [2026]. [Online PDF]. Available at: [<https://www.benchchem.com/product/b1174771/docs#application-notes-and-protocols-validating-grb10-interactions-using-proximity-ligation-assay>]

---

#### Disclaimer & Data Validity:

The information provided in this document is for Research Use Only (RUO) and is strictly not intended for diagnostic or therapeutic procedures. While BenchChem strives to provide accurate protocols, we make no warranties, express or implied, regarding the fitness of this product for every specific experimental setup.

**Technical Support:** The protocols provided are for reference purposes. Unsure if this reagent suits your experiment?

**Need Industrial/Bulk Grade?** [Request Custom Synthesis Quote](#)

# BenchChem

Our mission is to be the trusted global source of essential and advanced chemicals, empowering scientists and researchers to drive progress in science and industry.

## Contact

Address: 3281 E Guasti Rd

Ontario, CA 91761, United States

Phone: (601) 213-4426

Email: [info@benchchem.com](mailto:info@benchchem.com)

[Contact our Ph.D. Support Team for a compatibility check](#)