

# A Guide to Inter-laboratory Comparison of Freon-11 Measurement Standards

**Author:** BenchChem Technical Support Team. **Date:** April 2026

## Compound of Interest

Compound Name:	Freon-11
CAS No.:	11126-05-9
Cat. No.:	B1174993

[Get Quote](#)

For Researchers, Scientists, and Drug Development Professionals

This guide provides an objective comparison of the measurement standards for **Freon-11** (trichlorofluoromethane, CFC-11), a potent ozone-depleting substance, as maintained by the world's leading atmospheric monitoring networks. The data and methodologies presented are essential for ensuring the global comparability of CFC-11 measurements, which is critical for verifying compliance with international treaties such as the Montreal Protocol.

## Data Presentation: Comparison of Major Global Networks

The two primary networks responsible for long-term, high-precision measurements of atmospheric CFC-11 are the National Oceanic and Atmospheric Administration's Global Monitoring Laboratory (NOAA/GML) and the Advanced Global Atmospheric Gases Experiment (AGAGE). Inter-laboratory comparisons and ongoing collaborations ensure the consistency of their data, which underpins scientific assessments of ozone depletion and climate change.

While direct "round-robin" style inter-laboratory comparison reports for CFC-11 are not frequently published in a consolidated format, the ongoing comparison of measurements from co-located stations and the exchange of calibrated air samples provide a continuous assessment of the measurement standards. A key aspect of this comparison is the consistency of their calibration scales.

Parameter	NOAA/GML	AGAGE	Consistency/Comparison
Calibration Scale	NOAA-2016	SIO-05	The ratio of NOAA to AGAGE measurements is $0.9993 \pm 0.0009$ , indicating excellent agreement.[1]
Instrumentation	Gas Chromatography with Electron Capture Detection (GC-ECD), Gas Chromatography-Mass Spectrometry (GC-MS)	Gas Chromatography with Electron Capture Detection (GC-MD), "Medusa" Gas Chromatography with Mass Spectrometry (GC-MS)	Both networks use similar high-precision gas chromatography techniques. AGAGE's "Medusa" system is notable for its cryogenic preconcentration, allowing for the measurement of a wide range of trace gases.
Measurement Uncertainty	Strives for high accuracy with detailed uncertainty analysis. For many trace gases, expanded uncertainties (k=2) are reported.[2][3]	High precision with reported precisions up to 0.1% RSD for some compounds measured by the Medusa GC-MS.	The consistency over time between the two networks for CFC-11 is approximately 1%. [1]
Sampling Network	In-situ measurements at baseline observatories and flask sampling from a global network of sites, including aircraft.[4]	A global network of coastal and mountain sites with high-frequency in-situ measurements.[5]	Both networks maintain long-term measurement records at globally distributed sites, with some co-located stations for direct comparison.[6]

## Experimental Protocols

The measurement of **Freon-11** at trace atmospheric concentrations requires meticulous experimental procedures to ensure accuracy and precision. The methodologies employed by NOAA/GML and AGAGE, while slightly different in their specific implementations, are based on the same fundamental principles of gas chromatography.

### NOAA/GML Freon-11 Measurement Protocol

The NOAA/GML measures CFC-11 through both in-situ and flask sampling programs.[4]

- In-Situ Measurements:
  - Instrumentation: Automated, on-site gas chromatographs with electron capture detectors (GC-ECDs) are deployed at NOAA's baseline observatories.[4]
  - Sampling: Air is sampled continuously from tall towers to ensure it is representative of the regional background atmosphere.
  - Calibration: The instruments are calibrated frequently using a suite of compressed gas standards that are traceable to the NOAA primary calibration scale (NOAA-2016 for CFC-11).[4]
- Flask Sampling Program:
  - Sample Collection: Air samples are collected in specially prepared flasks from a global network of surface sites and from aircraft profiles.
  - Analysis: The flasks are returned to NOAA's central laboratory in Boulder, Colorado, for analysis on custom-built gas chromatograph systems, including GC-MS.[4]
  - Data Combination: Data from the different programs are combined into a long-term dataset, with adjustments made for any known biases between measurement systems.[4]

### AGAGE Freon-11 Measurement Protocol

The AGAGE network focuses on high-frequency, in-situ measurements at globally distributed sites.[5]

- Instrumentation:
  - The primary instrument used for CFC-11 and a wide range of other trace gases is the "Medusa" Gas Chromatograph with Mass Spectrometry (GC-MS).[7]
  - This system utilizes a cryogenic preconcentration technique to trap and enrich trace gases from a large volume of air, enabling highly precise measurements.
- Sampling and Analysis:
  - Air is sampled from tall towers at each station.
  - The Medusa GC-MS system is fully automated, performing frequent measurements of both ambient air and calibration standards.
- Calibration:
  - The AGAGE measurements are tied to the Scripps Institution of Oceanography (SIO) calibration scales, with CFC-11 being reported on the SIO-05 scale.[8]
  - A hierarchy of calibration standards is used to ensure the long-term stability and consistency of measurements across the network.

## Mandatory Visualization

The following diagrams illustrate the key workflows and relationships in the inter-laboratory comparison of **Freon-11** measurement standards.

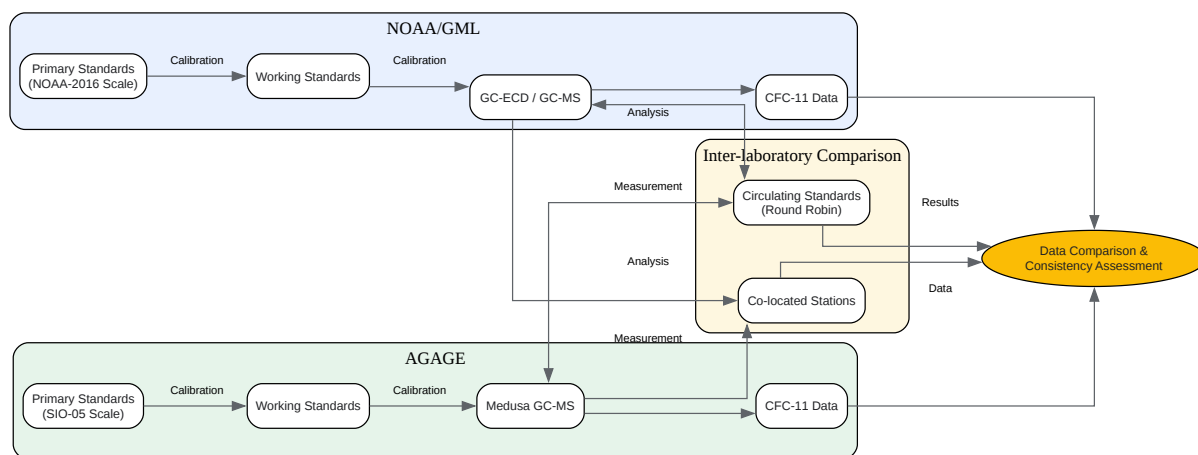

[Click to download full resolution via product page](#)

Caption: Workflow of an inter-laboratory comparison for **Freon-11** measurements.

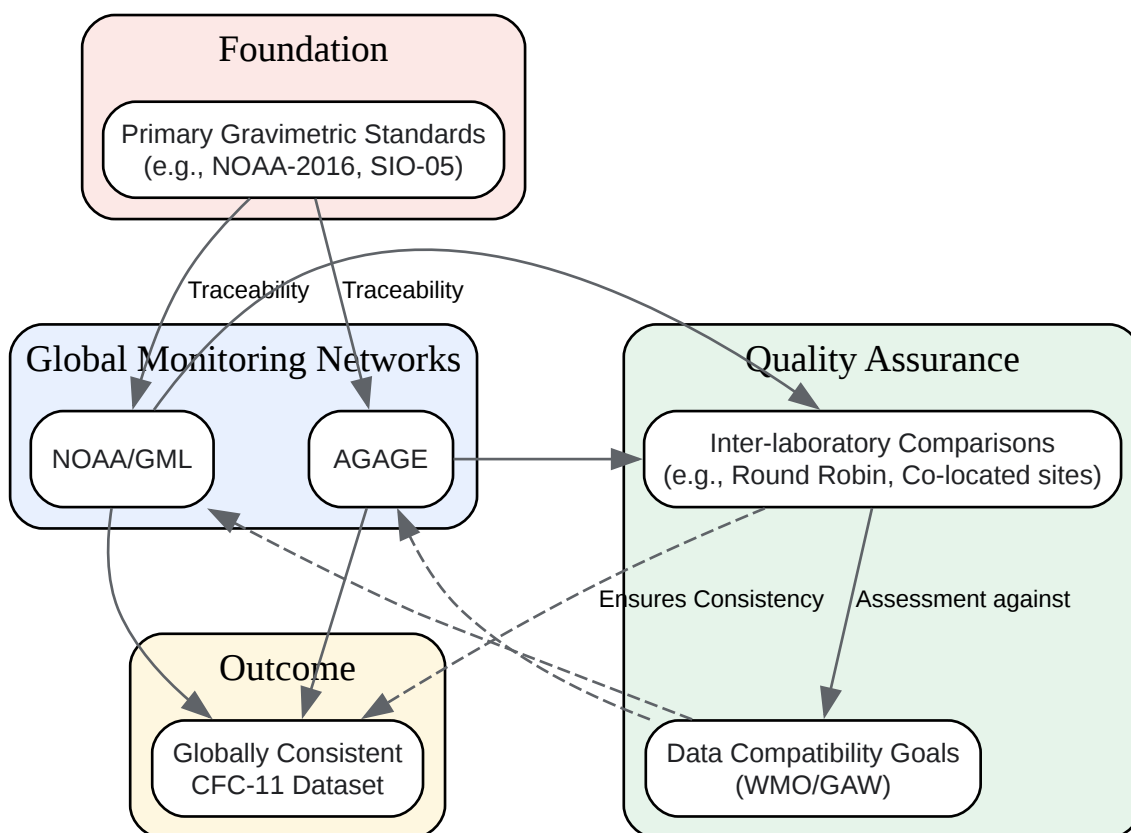

[Click to download full resolution via product page](#)

### Need Custom Synthesis?

BenchChem offers custom synthesis for rare earth carbides and specific isotopic labeling.

Email: [info@benchchem.com](mailto:info@benchchem.com) or [Request Quote Online](#).

## References

- [1. essd.copernicus.org \[essd.copernicus.org\]](https://essd.copernicus.org)
- [2. CCL - NOAA Global Monitoring Laboratory \[gml.noaa.gov\]](https://gml.noaa.gov)
- [3. repository.library.noaa.gov \[repository.library.noaa.gov\]](https://repository.library.noaa.gov)
- [4. LOGOS - NOAA Global Monitoring Laboratory \[gml.noaa.gov\]](https://gml.noaa.gov)
- [5. ESSD - History of chemically and radiatively important atmospheric gases from the Advanced Global Atmospheric Gases Experiment \(AGAGE\) \[essd.copernicus.org\]](https://essd.copernicus.org)

- [6. Global CFC emissions now declining again as expected under the Montreal Protocol – Atmospheric Composition & Chemistry \[research.csiro.au\]](#)
- [7. AGAGE - Advanced Global Atmospheric Gases Experiment \[www-air.larc.nasa.gov\]](#)
- [8. researchgate.net \[researchgate.net\]](#)
- To cite this document: BenchChem. [A Guide to Inter-laboratory Comparison of Freon-11 Measurement Standards]. BenchChem, [2026]. [Online PDF]. Available at: [\[https://www.benchchem.com/product/b1174993/docs#a-guide-to-inter-laboratory-comparison-of-freon-11-measurement-standards\]](https://www.benchchem.com/product/b1174993/docs#a-guide-to-inter-laboratory-comparison-of-freon-11-measurement-standards)

---

### Disclaimer & Data Validity:

The information provided in this document is for Research Use Only (RUO) and is strictly not intended for diagnostic or therapeutic procedures. While BenchChem strives to provide accurate protocols, we make no warranties, express or implied, regarding the fitness of this product for every specific experimental setup.

**Technical Support:** The protocols provided are for reference purposes. Unsure if this reagent suits your experiment?

**Need Industrial/Bulk Grade?** [Request Custom Synthesis Quote](#)

## BenchChem

Our mission is to be the trusted global source of essential and advanced chemicals, empowering scientists and researchers to drive progress in science and industry.

### Contact

Address: 3281 E Guasti Rd  
Ontario, CA 91761, United States  
Phone: (601) 213-4426  
Email: [info@benchchem.com](mailto:info@benchchem.com)

[Contact our Ph.D. Support Team for a compatibility check](#)

