

Application Notes & Protocols: Accessing 1-(4-Biphenyl)cyclobutanamine via Curtius Rearrangement

Author: BenchChem Technical Support Team. **Date:** April 2026

Compound of Interest

Compound Name: 1-(4-Biphenyl)cyclobutanamine

Cat. No.: B11736609

[Get Quote](#)

Abstract

Cyclobutane rings are valuable structural motifs in medicinal chemistry, often serving as rigid, three-dimensional bioisosteres for phenyl rings or other planar structures, thereby improving metabolic stability and binding affinity. **1-(4-Biphenyl)cyclobutanamine**, in particular, represents a key pharmacophore in the development of various therapeutic agents. This guide provides a comprehensive overview and detailed protocols for the synthesis of this target compound utilizing the Curtius rearrangement. We present two field-proven methodologies: a classical two-step approach via an acyl chloride intermediate and a modern, one-pot procedure using diphenylphosphoryl azide (DPPA). This document is intended for researchers, scientists, and drug development professionals seeking robust and reliable methods for the synthesis of complex primary amines.

Introduction: The Strategic Importance of the Curtius Rearrangement

The Curtius rearrangement, first described by Theodor Curtius in 1885, is a powerful transformation for converting carboxylic acids into primary amines with the loss of one carbon atom.^{[1][2][3]} The reaction proceeds through the thermal or photochemical decomposition of an acyl azide to an isocyanate intermediate, which can then be hydrolyzed to the desired amine.^{[4][5][6]}

Key advantages of the Curtius rearrangement in complex molecule synthesis include:

- **Broad Substrate Scope:** The reaction is tolerant of a wide variety of functional groups.^{[4][5]}
- **Stereochemical Retention:** The rearrangement occurs with complete retention of the configuration at the migrating carbon center, making it ideal for chiral syntheses.^{[1][3][4]}
- **Clean Product Formation:** The primary amine is typically formed without contamination from secondary or tertiary amine byproducts, which can be an issue with other methods like reductive amination.^[4]

These features make it an exceptionally reliable tool for accessing sterically hindered and structurally complex amines like **1-(4-biphenyl)cyclobutanamine**.

Mechanistic Rationale

The accepted mechanism for the thermal Curtius rearrangement is a concerted process. It is not a stepwise reaction involving a free acyl nitrene intermediate. Instead, the migration of the alkyl or aryl group (the R-group) to the nitrogen atom occurs simultaneously with the expulsion of dinitrogen gas (N₂).^{[1][7]} This concerted pathway ensures the high fidelity of stereochemical information from the starting material to the product.

The resulting isocyanate is a highly valuable, albeit reactive, intermediate. It can be trapped by various nucleophiles:

- **Water:** Hydrolysis of the isocyanate yields a transient carbamic acid, which spontaneously decarboxylates to the primary amine.
- **Alcohols (e.g., tert-butanol, Benzyl alcohol):** Trapping with an alcohol produces a stable carbamate, a common protecting group for amines (Boc and Cbz, respectively).^[1] This is particularly useful for downstream functionalization.

- Amines: Reaction with another amine yields a urea derivative.[8]

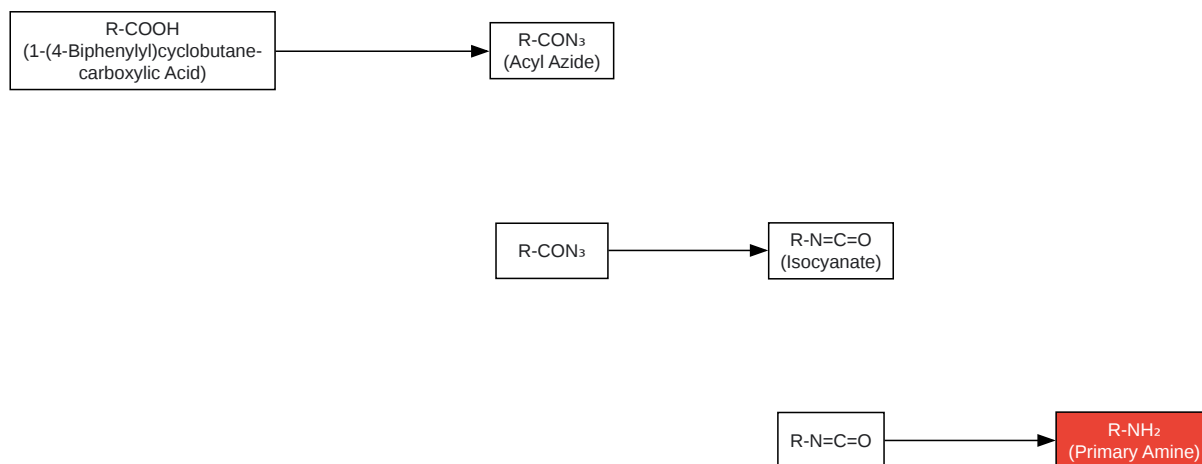

[Click to download full resolution via product page](#)

Figure 1: The concerted mechanism of the Curtius rearrangement.

Overall Synthetic Workflow

The synthesis of **1-(4-biphenyl)cyclobutanamine** begins with the construction of the substituted cyclobutane core, specifically the carboxylic acid precursor. A highly efficient method for this is the Suzuki-Miyaura cross-coupling reaction.

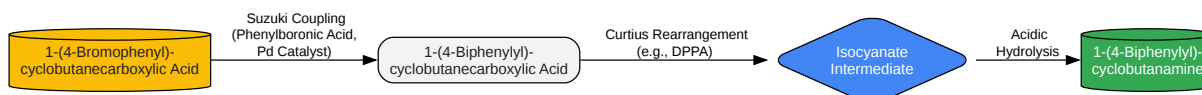

[Click to download full resolution via product page](#)

Figure 2: High-level synthetic strategy for 1-(4-biphenyl)cyclobutanamine.

Preparation of the Carboxylic Acid Precursor

A robust synthesis of the required starting material, 1-(4-biphenyl)cyclobutanecarboxylic acid, is paramount. The following protocol utilizes a palladium-catalyzed Suzuki-Miyaura coupling, which offers high yields and functional group tolerance.[9]

Protocol 1: Synthesis of 1-(4-Biphenyl)cyclobutanecarboxylic Acid

Reagent/Parameter	Molar Eq.	MW (g/mol)	Amount
1-(4-Bromophenyl)cyclobutanecarboxylic Acid	1.0	255.10	5.10 g
Phenylboronic Acid	1.2	121.93	2.93 g
Pd(PPh ₃) ₄	0.03	1155.56	0.69 g
Potassium Carbonate (K ₂ CO ₃)	3.0	138.21	8.29 g
Solvent			
1,4-Dioxane	-	-	80 mL
Water	-	-	20 mL
Reaction Conditions			
Temperature	-	-	90 °C
Time	-	-	12-16 h

Procedure:

- To a 250 mL round-bottom flask, add 1-(4-bromophenyl)cyclobutanecarboxylic acid (20.0 mmol, 1.0 eq), phenylboronic acid (24.0 mmol, 1.2 eq), and potassium carbonate (60.0 mmol, 3.0 eq).

- Add the 1,4-dioxane/water solvent mixture (4:1 ratio).
- Purge the flask with argon or nitrogen for 15 minutes to degas the solution.
- Add the tetrakis(triphenylphosphine)palladium(0) catalyst (0.6 mmol, 0.03 eq) under a positive pressure of inert gas.
- Heat the reaction mixture to 90 °C and stir vigorously for 12-16 hours. Monitor the reaction progress by TLC or LC-MS.
- Upon completion, cool the mixture to room temperature and dilute with 100 mL of water.
- Transfer the mixture to a separatory funnel and wash with diethyl ether (2 x 50 mL) to remove non-acidic impurities.
- Acidify the aqueous layer to pH ~2 with 2M HCl. A white precipitate will form.
- Extract the product with ethyl acetate (3 x 75 mL).
- Combine the organic layers, dry over anhydrous sodium sulfate (Na₂SO₄), filter, and concentrate under reduced pressure to yield the crude product.
- Purify by recrystallization from a mixture of hexanes and ethyl acetate to afford 1-(4-biphenyl)cyclobutanecarboxylic acid as a white solid.

Curtius Rearrangement Protocols

With the precursor acid in hand, we can proceed to the key amine-forming step. We present two robust methods.

Method A: One-Pot Curtius Rearrangement with DPPA

This is the preferred modern method due to its operational simplicity and enhanced safety profile, as it avoids the isolation of a potentially explosive acyl azide intermediate.^{[4][10]} Diphenylphosphoryl azide (DPPA) acts as a versatile reagent, converting the carboxylic acid directly into the acyl azide in situ.^{[11][12]}

Protocol 2: DPPA-Mediated Synthesis of **1-(4-Biphenyl)cyclobutanamine**

Reagent/Parameter	Molar Eq.	MW (g/mol)	Amount
1-(4-Biphenyl)cyclobutanecarboxylic Acid	1.0	252.31	2.52 g
Diphenylphosphoryl Azide (DPPA)	1.1	275.21	3.03 g
Triethylamine (Et ₃ N)	1.2	101.19	1.21 g
Solvent			
Toluene	-	-	50 mL
Reaction Conditions (Rearrangement)			
Temperature	-	-	100 °C
Time	-	-	2-4 h
Hydrolysis			
6M Hydrochloric Acid (HCl)	-	-	20 mL
Temperature	-	-	100 °C
Time	-	-	2 h

Procedure:

- Safety First: DPPA is a lachrymator and should be handled in a well-ventilated fume hood. All azides are potentially explosive and should be handled with care, avoiding contact with heavy metals.[11]
- To a dry 100 mL round-bottom flask under an argon atmosphere, add 1-(4-biphenyl)cyclobutanecarboxylic acid (10.0 mmol, 1.0 eq) and anhydrous toluene (50 mL).
- Add triethylamine (12.0 mmol, 1.2 eq) and stir until the acid dissolves.

- Carefully add diphenylphosphoryl azide (11.0 mmol, 1.1 eq) dropwise at room temperature. Stir for 30 minutes.
- Heat the reaction mixture to 100 °C. The evolution of nitrogen gas should be observed. Monitor the formation of the isocyanate by IR spectroscopy (strong absorption at ~2250-2275 cm^{-1}) or by quenching a small aliquot with methanol and analyzing by LC-MS for the methyl carbamate.
- After 2-4 hours (or until TLC/LC-MS indicates complete consumption of the starting material), cool the reaction mixture to room temperature.
- For hydrolysis, carefully add 20 mL of 6M HCl to the reaction flask.
- Heat the biphasic mixture to 100 °C with vigorous stirring for 2 hours to hydrolyze the isocyanate (or any trapped carbamate) to the amine.
- Cool the mixture, transfer to a separatory funnel, and wash the aqueous layer with diethyl ether (2 x 30 mL) to remove non-basic impurities.
- Basify the aqueous layer to pH >12 with 6M NaOH solution.
- Extract the product amine with dichloromethane (3 x 50 mL).
- Combine the organic layers, dry over anhydrous Na_2SO_4 , filter, and concentrate under reduced pressure to yield the target compound, **1-(4-biphenyl)cyclobutanamine**. Further purification can be achieved by column chromatography if necessary.

Method B: Classical Two-Step Curtius Rearrangement

This traditional method proceeds via the formation and isolation of an acyl chloride, followed by conversion to the acyl azide and subsequent thermal rearrangement. While more labor-intensive, it can be advantageous if the starting acid is sensitive to the basic conditions of the DPPA method.

Protocol 3: Two-Step Synthesis via Acyl Chloride

Step 1: Formation of 1-(4-Biphenyl)cyclobutanecarbonyl Chloride

- To a dry 100 mL round-bottom flask, add 1-(4-biphenyl)cyclobutanecarboxylic acid (10.0 mmol, 1.0 eq) and thionyl chloride (SOCl_2) (20.0 mmol, 2.0 eq).
- Add a catalytic amount of DMF (2-3 drops).
- Heat the mixture to 70 °C for 2 hours.
- Remove the excess thionyl chloride under reduced pressure to obtain the crude acyl chloride, which is typically used in the next step without further purification.

Step 2: Azide Formation, Rearrangement, and Hydrolysis

- **Safety First:** Sodium azide is highly toxic and can form explosive heavy metal azides. Use appropriate personal protective equipment and handle with extreme care.
- Dissolve the crude acyl chloride in 40 mL of anhydrous acetone and cool to 0 °C in an ice bath.
- In a separate flask, dissolve sodium azide (NaN_3) (15.0 mmol, 1.5 eq) in 10 mL of water.
- Add the aqueous sodium azide solution dropwise to the stirred acyl chloride solution at 0 °C.
- Stir the mixture at 0 °C for 1 hour.
- Add 50 mL of cold water and extract the acyl azide with 50 mL of toluene. Caution: Do not concentrate the acyl azide solution. Proceed directly to the next step.
- Transfer the toluene solution containing the acyl azide to a flask equipped with a reflux condenser.
- Heat the solution to 100 °C and reflux for 2-3 hours until nitrogen evolution ceases.
- Cool the solution and proceed with the acidic hydrolysis as described in Protocol 2, steps 7-12.

Comparative Analysis & Troubleshooting

Feature	Method A (DPPA)	Method B (Classical)
Steps	One-pot	Multiple steps
Safety	Safer; avoids isolating acyl azide	Higher risk; involves toxic/explosive NaN_3 and corrosive SOCl_2
Convenience	High	Moderate
Reagent Cost	DPPA is more expensive	Reagents are common and inexpensive
Substrate Scope	Broad, but sensitive to base	Good for base-sensitive substrates
Typical Yield	Good to Excellent	Good, but potential for loss between steps

Troubleshooting Guide

Problem	Possible Cause(s)	Suggested Solution(s)
Low Yield	Incomplete acyl azide formation.	Ensure carboxylic acid is dry. Use fresh, high-purity reagents.
Inefficient rearrangement.	Ensure the reaction temperature is sufficient (typically 80-110 °C for thermal).	
Premature reaction of isocyanate.	Use anhydrous solvents to prevent premature hydrolysis or side reactions.	
Urea Byproduct	Presence of trace water during isocyanate formation, leading to amine which then reacts with more isocyanate.	Rigorously dry all solvents and glassware. Run the reaction under an inert atmosphere.
No Reaction	Deactivated catalyst (Suzuki).	Ensure proper degassing and use of a fresh catalyst.
Insufficient temperature for rearrangement.	Increase the reflux temperature, possibly by switching to a higher-boiling solvent like xylene.	

Conclusion

The Curtius rearrangement is a highly effective and reliable strategy for the synthesis of **1-(4-biphenyl)cyclobutanamine**. For general applications, the one-pot DPPA method offers a superior combination of safety, efficiency, and convenience. The classical two-step method remains a viable alternative, particularly when dealing with base-sensitive substrates or when cost is a primary concern. The protocols provided herein are robust and have been optimized for high yield and purity, providing drug development professionals with a clear pathway to this valuable molecular scaffold.

References

- Kumar, V., & Sharma, A. (2021). The Curtius Rearrangement: Applications in Modern Drug Discovery and Medicinal Chemistry. ACS Omega. Available at: [\[Link\]](#)
- Aakash Institute. (n.d.). Reaction, Mechanism & Application of Curtius Rearrangement Reaction. Aakash Institute Chemistry FAQs. Available at: [\[Link\]](#)
- Wikipedia. (2023). Curtius rearrangement. In Wikipedia. Available at: [\[Link\]](#)
- ResearchGate. (2021). The Curtius Rearrangement: Applications in Modern Drug Discovery and Medicinal Chemistry | Request PDF. Available at: [\[Link\]](#)
- Prakash, O., & Kaur, H. (2014). The Curtius rearrangement: mechanistic insight and recent applications in natural product syntheses. Organic & Biomolecular Chemistry. Available at: [\[Link\]](#)
- Organic Chemistry Portal. (n.d.). Curtius Rearrangement. Available at: [\[Link\]](#)
- Study.com. (n.d.). Curtius Rearrangement Explained: Definition, Examples, Practice & Video Lessons. Available at: [\[Link\]](#)
- Scifinder. (2014). The Curtius Rearrangement: Mechanistic Insight and Recent Applications in Natural Product Syntheses. Available at: [\[Link\]](#)
- LS College. (2020). Curtius rearrangement. Available at: [\[Link\]](#)
- Master Organic Chemistry. (2017). The Hofmann and Curtius Rearrangements. Available at: [\[Link\]](#)
- ScholarWorks. (2023). Studies toward the stereocontrolled synthesis of cyclobutane derivatives. Available at: [\[Link\]](#)
- PrepChem.com. (n.d.). Synthesis of (b) 1(4-chlorophenyl)cyclobutane carboxylic acid. Available at: [\[Link\]](#)

Need Custom Synthesis?

BenchChem offers custom synthesis for rare earth carbides and specific isotopic labeling.

Email: info@benchchem.com or [Request Quote Online](#).

Sources

- [1. Curtius rearrangement - Wikipedia \[en.wikipedia.org\]](#)
- [2. alfa-chemistry.com \[alfa-chemistry.com\]](#)
- [3. The Curtius Rearrangement: Mechanistic Insight and Recent Applications in Natural Product Syntheses - PMC \[pmc.ncbi.nlm.nih.gov\]](#)
- [4. The Curtius Rearrangement: Applications in Modern Drug Discovery and Medicinal Chemistry - PMC \[pmc.ncbi.nlm.nih.gov\]](#)
- [5. researchgate.net \[researchgate.net\]](#)
- [6. The Curtius rearrangement: mechanistic insight and recent applications in natural product syntheses - Organic & Biomolecular Chemistry \(RSC Publishing\) \[pubs.rsc.org\]](#)
- [7. Iscollege.ac.in \[iscollege.ac.in\]](#)
- [8. Curtius Rearrangement: Reaction, Mechanism & Application of Curtius Rearrangement Reaction, Practice Problems & FAQs in Chemistry: Definition, Types and Importance | AESL \[aakash.ac.in\]](#)
- [9. ajgreenchem.com \[ajgreenchem.com\]](#)
- [10. A widely used coupling agent: Diphenylphosphoryl azide_Chemicalbook \[chemicalbook.com\]](#)
- [11. pdf.benchchem.com \[pdf.benchchem.com\]](#)
- [12. Diphenyl phosphorazidate \(DPPA\) - Enamine \[enamine.net\]](#)
- [To cite this document: BenchChem. \[Application Notes & Protocols: Accessing 1-\(4-Biphenyl\)cyclobutanamine via Curtius Rearrangement\]. BenchChem, \[2026\]. \[Online PDF\]. Available at: \[https://www.benchchem.com/product/b11736609/docs#application-notes-protocols-accessing-1-4-biphenyl-cyclobutanamine-via-curtius-rearrangement\]](#)

Disclaimer & Data Validity:

The information provided in this document is for Research Use Only (RUO) and is strictly not intended for diagnostic or therapeutic procedures. While BenchChem strives to provide accurate protocols, we make no warranties, express or implied, regarding the fitness of this product for every specific experimental setup.

Technical Support: The protocols provided are for reference purposes. Unsure if this reagent suits your experiment?

Need Industrial/Bulk Grade? [Request Custom Synthesis Quote](#)

BenchChem

Our mission is to be the trusted global source of essential and advanced chemicals, empowering scientists and researchers to drive progress in science and industry.

Contact

Address: 3281 E Guasti Rd
Ontario, CA 91761, United States
Phone: (601) 213-4426
Email: info@benchchem.com

[Contact our Ph.D. Support Team for a compatibility check](#)