

Comparative Reactivity Guide: Allylic vs. Homoallylic Architectures

Author: BenchChem Technical Support Team. **Date:** May 2026

Compound of Interest

Compound Name: 3-Buten-1-ol, 4-phenyl-

CAS No.: 770-36-5

Cat. No.: B11718524

[Get Quote](#)

Executive Summary & Structural Divergence

This guide provides a technical analysis of the reactivity differences between Cinnamyl Alcohol (Allylic) and 4-Phenyl-3-buten-1-ol (Homoallylic). While both molecules share a styrenyl core (), the insertion of a single methylene spacer () in 4-phenyl-3-buten-1-ol fundamentally alters their electronic profile, oxidation potential, and cyclization modes.

- Cinnamyl Alcohol:

(Allylic System)

- 4-Phenyl-3-buten-1-ol:

(Homoallylic System)

Key Takeaway: The "Methylene Spacer Effect" acts as an electronic insulator. Cinnamyl alcohol is defined by orbital overlap (hyperconjugation) facilitating facile oxidation and directed

epoxidation. 4-Phenyl-3-buten-1-ol is defined by chain flexibility, facilitating intramolecular cyclization (5-exo-trig) while resisting mild oxidants.

Reactivity Domain A: Chemoselective Oxidation

The most immediate operational difference is the susceptibility to Manganese Dioxide (). This reagent is the industry standard for distinguishing allylic/benzylic alcohols from saturated/homoallylic counterparts.

Mechanism & Performance

- Cinnamyl Alcohol: The hydroxyl group is allylic.[1] The forming radical/carbocation intermediate during oxidation is stabilized by resonance with the adjacent -system. rapidly converts this to Cinnamaldehyde.
- 4-Phenyl-3-buten-1-ol: The hydroxyl group is isolated. The -system cannot stabilize the transition state at the C1 position. Consequently, it is inert to standard activated conditions.

Comparative Data: Oxidation[2][3]

Feature	Cinnamyl Alcohol	4-Phenyl-3-buten-1-ol
Reagent	Activated (10-20 eq)	Activated (10-20 eq)
Solvent	or	or
Time	1 - 4 Hours	> 24 Hours (No Reaction)
Product	Cinnamaldehyde (>90% Yield)	Recovered Starting Material
Kinetics	Fast (min)	Negligible

Experimental Protocol: Selective Oxidation

Objective: Selective oxidation of allylic alcohol in the presence of homoallylic impurities.

- Preparation: Suspend activated
(1.74 g, 20 mmol) in dry
(20 mL).
- Addition: Add Cinnamyl Alcohol (134 mg, 1.0 mmol) in one portion.
- Monitoring: Stir vigorously at room temperature. Monitor by TLC (Hexane/EtOAc 4:1).
Cinnamyl alcohol (
) disappears; Cinnamaldehyde (
) appears.
- Workup: Filter through a pad of Celite to remove manganese oxides. Rinse with
.
- Isolation: Concentrate filtrate in vacuo.

- Note: If applied to 4-phenyl-3-buten-1-ol, the TLC will show no change after 24 hours.

Reactivity Domain B: Electrophilic Cyclization (Iodoetherification)

Here, the reactivity profile inverts. The homoallylic architecture of 4-phenyl-3-buten-1-ol is geometrically privileged for intramolecular cyclization, specifically 5-exo-trig ring closure, obeying Baldwin's Rules.

Mechanism & Performance

- 4-Phenyl-3-buten-1-ol: Upon activation of the alkene with Iodine (), the pendant hydroxyl group attacks the iodonium intermediate. The 2-carbon spacer allows a low-strain 5-membered ring (tetrahydrofuran) to form.
- Cinnamyl Alcohol: Attempted iodoetherification typically fails or yields complex mixtures. A 4-endo-trig closure (to form an oxetane) is disfavored energetically and sterically.

Visualization: Pathway Divergence

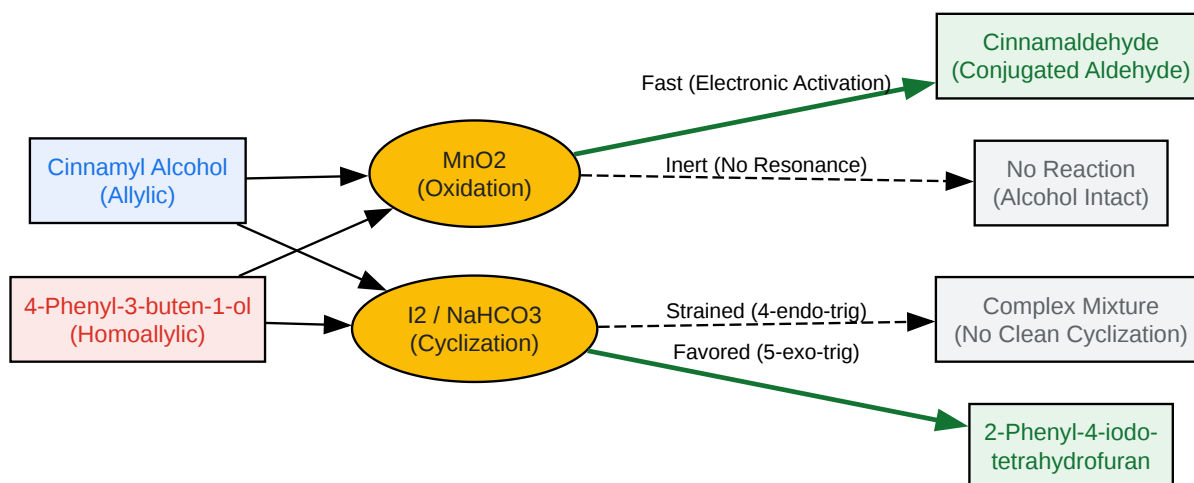

[Click to download full resolution via product page](#)

Caption: Divergent reactivity pathways. Cinnamyl alcohol dominates in oxidation; 4-phenyl-3-buten-1-ol dominates in cyclization.

Experimental Protocol: Iodoetherification

Objective: Synthesis of 2-phenyl-4-iodotetrahydrofuran from 4-phenyl-3-buten-1-ol.

- Setup: Dissolve 4-phenyl-3-buten-1-ol (148 mg, 1.0 mmol) in dry Acetonitrile (, 10 mL).
- Base: Add Sodium Bicarbonate (, 252 mg, 3.0 mmol) to buffer the generated HI.
- Cyclization: Cool to 0°C. Add Iodine (, 508 mg, 2.0 mmol) portion-wise.
- Reaction: Allow to warm to room temperature and stir for 3 hours in the dark.
- Quench: Add saturated aqueous (thiosulfate) until the iodine color disappears.
- Extraction: Extract with Diethyl Ether (3 x 15 mL). Dry over .
- Result: Evaporation yields the tetrahydrofuran derivative (typically >85% yield, mixture of cis/trans diastereomers).

Reactivity Domain C: Asymmetric Epoxidation[4][5]

The "Spacer Effect" critically impacts stereocontrol in Sharpless Asymmetric Epoxidation (SAE).

- Cinnamyl Alcohol: The ideal substrate. The allylic OH coordinates Titanium (), rigidly directing the tartrate ligand to the alkene face. Enantiomeric Excess (ee) typically >95%.
- 4-Phenyl-3-buten-1-ol: The extra carbon allows too much conformational freedom in the transition state. The coordination to Ti is weaker/floppier.

- Result: Much slower reaction rates (often 10-20x slower) and significantly lower ee (<50-60%) using standard SAE conditions.
- Alternative: Homoallylic alcohols often require Vanadium-catalyzed epoxidation (e.g., / TBHP) to achieve acceptable reactivity, though enantioselectivity remains challenging without specialized ligands.

References

- Manganese Dioxide Oxidation Selectivity
 - Gritter, R. J., & Wallace, T. J. (1959). The Manganese Dioxide Oxidation of Allylic Alcohols. [2] The Journal of Organic Chemistry.
- Iodoetherification of Homoallylic Alcohols
 - Bartlett, P. A., & Myerson, J. (1978). Stereoselective epoxidation of acyclic homoallylic alcohols. Journal of the American Chemical Society.
- Sharpless Epoxidation Kinetics
 - Katsuki, T., & Sharpless, K. B. (1980). The first practical method for asymmetric epoxidation. Journal of the American Chemical Society.
- Baldwin's Rules for Ring Closure
 - Baldwin, J. E. (1976). Rules for ring closure.

Need Custom Synthesis?

BenchChem offers custom synthesis for rare earth carbides and specific isotopic labeling.

Email: info@benchchem.com or [Request Quote Online](#).

Sources

- 1. [mdpi.com](https://www.mdpi.com) [mdpi.com]

- [2. youtube.com \[youtube.com\]](https://www.youtube.com)
- To cite this document: BenchChem. [Comparative Reactivity Guide: Allylic vs. Homoallylic Architectures]. BenchChem, [2026]. [Online PDF]. Available at: [<https://www.benchchem.com/product/b11718524/docs#comparative-reactivity-guide-allylic-vs-homoallylic-architectures>]

Disclaimer & Data Validity:

The information provided in this document is for Research Use Only (RUO) and is strictly not intended for diagnostic or therapeutic procedures. While BenchChem strives to provide accurate protocols, we make no warranties, express or implied, regarding the fitness of this product for every specific experimental setup.

Technical Support: The protocols provided are for reference purposes. Unsure if this reagent suits your experiment?

Need Industrial/Bulk Grade? [Request Custom Synthesis Quote](#)

BenchChem

Our mission is to be the trusted global source of essential and advanced chemicals, empowering scientists and researchers to drive progress in science and industry.

Contact

Address: 3281 E Guasti Rd
Ontario, CA 91761, United States
Phone: (601) 213-4426
Email: info@benchchem.com

[Contact our Ph.D. Support Team for a compatibility check](#)