

Advanced Methodologies in 2H-Indazole Synthesis: A Comprehensive Technical Guide

Author: BenchChem Technical Support Team. **Date:** April 2026

Compound of Interest

Compound Name:	<i>methyl 2,3-dimethyl-2H-indazole-6-carboxylate</i>
CAS No.:	1638764-86-9
Cat. No.:	B11717422

[Get Quote](#)

The 2H-indazole scaffold is a privileged pharmacophore embedded in numerous bioactive molecules, including modulators of poly(ADP-ribose) polymerase (PARP), vascular endothelial growth factor (VEGF), and glucokinase (GK)[1]. Historically, accessing 2H-indazoles via direct alkylation or arylation of commercially available 1H-indazoles has been plagued by poor regioselectivity. This typically yields intractable mixtures of N1- and N2-substituted isomers due to the thermodynamic preference for the 1H-tautomer[2]. Consequently, modern synthetic efforts have pivoted toward de novo cyclization strategies and highly controlled catalytic cross-couplings.

Designed for drug development professionals and application scientists, this guide dissects the mechanistic causality and operational protocols of the most robust, field-proven methodologies for 2H-indazole synthesis.

Reductive Cyclization: The Evolution of the Cadogan Reaction

The classical Cadogan reaction synthesizes 2H-indazoles from ortho-nitroaromatic compounds via exhaustive deoxygenation, traditionally requiring harsh conditions (e.g., refluxing trialkyl phosphites at $>150\text{ }^{\circ}\text{C}$)[1]. Recent advancements have transformed this into a mild, operationally simple one-pot condensation-reductive cyclization cascade[2].

Mechanistic Causality

By utilizing tri-n-butylphosphine (PBU₃) in a protic solvent (isopropanol), the reaction temperature is drastically lowered to $80\text{ }^{\circ}\text{C}$ [2]. The causality of this improvement lies in the high nucleophilicity of PBU₃, which efficiently attacks the nitro group. While exhaustive deoxygenation to a nitrene intermediate is the classical model, recent isolation of 2H-indazole N-oxides via interrupted Cadogan/Davis-Beirut reactions provides direct evidence that oxygenated species (nitroso imines) are highly competent intermediates prior to final cyclization[1].

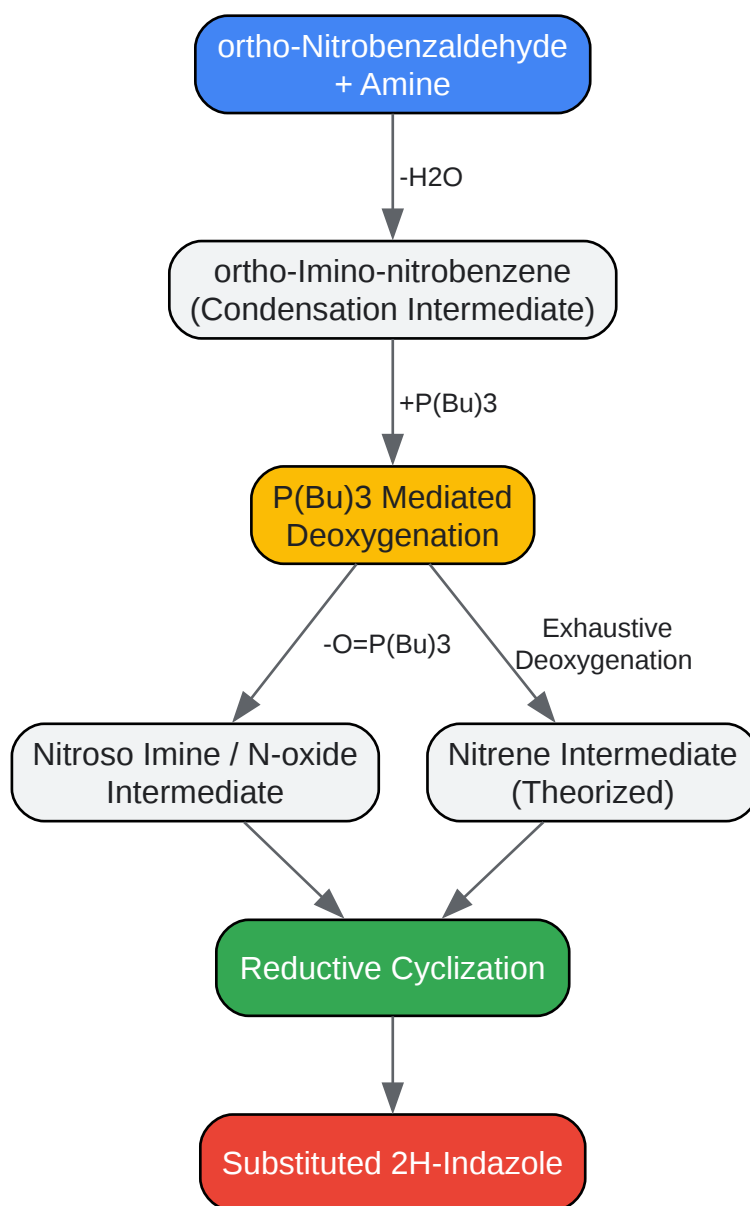

[Click to download full resolution via product page](#)

Figure 1: Mechanistic workflow of the one-pot condensation-Cadogan reductive cyclization.

Self-Validating Experimental Protocol: One-Pot Condensation-Cadogan Cyclization

- **Imine Formation:** To an oven-dried flask, add ortho-nitrobenzaldehyde (1.0 equiv) and the primary amine (1.1 equiv) in isopropanol (0.5 M). Stir at room temperature for 2 hours. **Validation:** The absence of the aldehyde proton (~10 ppm) via crude ¹H NMR confirms complete conversion to the ortho-imino-nitrobenzene intermediate.

- Reductive Cyclization: Add tri-n-butylphosphine (P Bu₃, 2.5 equiv) dropwise to the reaction mixture.
- Heating: Elevate the temperature to 80 °C and stir for 12 hours.
- Isolation: Cool to room temperature, concentrate under reduced pressure, and purify via silica gel chromatography. Expert Note: Exogenous hydrochloride salts are deleterious; free bases of amines must be used. Interestingly, using optically pure α -methyl benzylamine in this cascade provides the indazole product with complete retention of stereochemistry, validating that detrimental isomerization of the imine intermediate does not occur under these specific conditions[2].

Transition Metal-Catalyzed Multicomponent Assemblies

Multicomponent reactions (MCRs) offer a highly convergent approach to molecular complexity. A landmark methodology utilizes a copper-catalyzed one-pot, three-component reaction of 2-bromobenzaldehydes, primary amines, and sodium azide.

Mechanistic Causality

The reaction is driven by a sequential bond-formation strategy. Initial condensation yields an imine. The copper catalyst (e.g., CuI) then facilitates a crucial ligand exchange and cross-coupling with NaN₃ to form an aryl azide intermediate. Control experiments reveal that while other metals (Pd, Ni, Co) only yield the intermediate imine, copper uniquely facilitates the subsequent N-N bond formation. The thermodynamic driving force is the intramolecular cyclization accompanied by the irreversible extrusion of nitrogen gas (N₂), rendering the overall process highly exergonic[3].

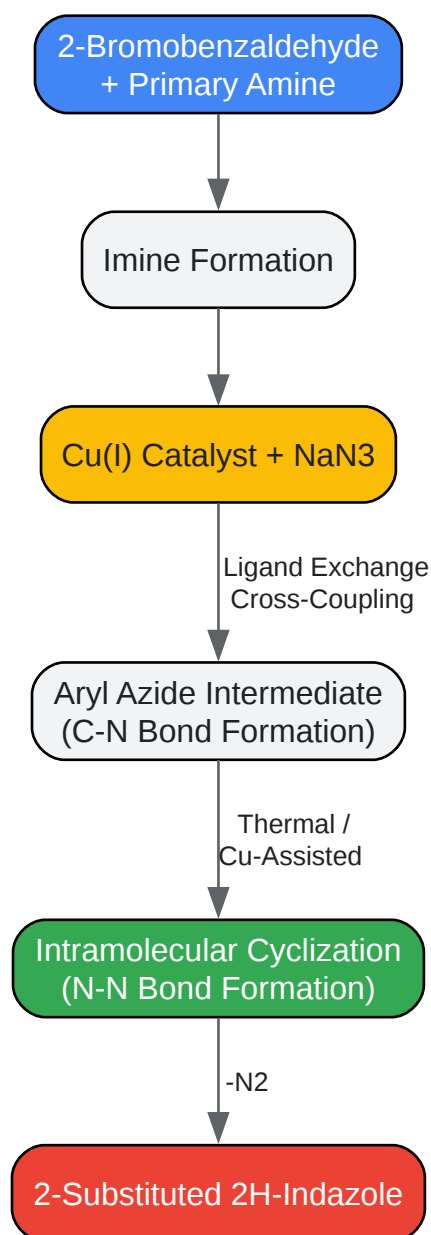

[Click to download full resolution via product page](#)

Figure 2: Sequential C-N and N-N bond formation in Cu-catalyzed multicomponent synthesis.

Self-Validating Experimental Protocol: Cu-Catalyzed Three-Component Reaction

- Reaction Setup: In an oven-dried reaction tube, combine 2-bromobenzaldehyde (1.0 mmol), primary amine (1.2 mmol), NaN₃(1.5 mmol), and CuI (10 mol%)[3].

- Solvent Addition: Add DMSO (3 mL) as the solvent. The high dielectric constant of DMSO stabilizes the ionic intermediates during the azide cross-coupling[3].
- Cyclization: Seal the tube and heat to 110 °C for 12-24 hours. Validation: The evolution of N₂ gas (bubbling) indicates the successful activation and decomposition of the aryl azide intermediate[3].
- Workup: Quench with water, extract with ethyl acetate, dry over MgSO₄, and purify via flash column chromatography to isolate the 2H-indazole[3].

Rhodium(III)-Catalyzed C-H Functionalization and Annulation

For advanced late-stage functionalization, Rh(III)-catalyzed formal [4+1] annulation of azobenzenes with aldehydes provides an elegant, one-step synthesis of N-aryl-2H-indazoles[4].

Mechanistic Causality

The azo functional group acts as an intrinsic directing group, coordinating to the Rh(III) center to facilitate regioselective ortho-C-H bond activation, forming a stable rhodacycle. Insertion of the aldehyde yields an alcohol intermediate. The azo moiety then serves a dual purpose, acting as an internal nucleophile for cyclative capture. Rapid aromatization expels the catalyst and yields the 2-aryl-2H-indazole[4].

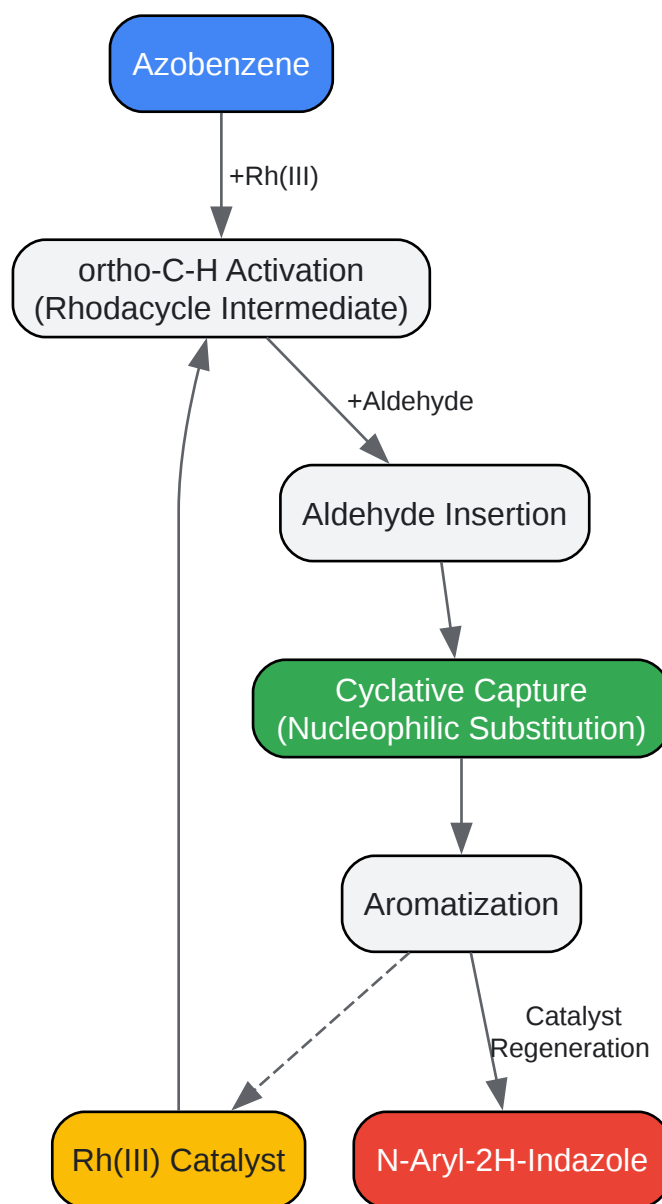

[Click to download full resolution via product page](#)

Figure 3: Catalytic cycle of Rh(III)-mediated [4+1] annulation of azobenzenes.

Regioselective Direct N-Alkylation/Arylation

While de novo synthesis avoids regioselectivity issues, direct functionalization of commercially available 1H-indazoles remains highly desirable. Recent breakthroughs have achieved complete N(2)-regiocontrol using a CuCl-catalyzed C-N cross-coupling with diaryliodonium salts[5].

Mechanistic Causality

Density functional theory (DFT) calculations reveal that the weak basicity of the triflate (TfO⁻) counterion in the system prevents the premature deprotonation of the indazole. This kinetic control ensures that the catalyst oxidation process is the rate-determining step, exclusively driving the coupling to the N(2) position[5].

Quantitative Data Summary

To facilitate experimental design, the following table summarizes the quantitative metrics and operational parameters of the discussed methodologies:

Synthetic Methodology	Key Reagents & Catalysts	Regioselectivity	Typical Yield Range	Primary Advantage
Condensation-Cadogan	PBu ₃ (2.5 eq), i-PrOH, 80 °C	Complete (De Novo)	65% - 95%	Mild conditions; stereoretention in chiral amines.
Cu-Catalyzed 3-CR	CuI (10 mol%), NaN ₃ , DMSO, 110 °C	Complete (De Novo)	50% - 85%	Utilizes readily available starting materials.
Rh(III) [4+1] Annulation	Rh(III) cat., MgSO ₄ , THF/Dioxane	Complete (De Novo)	60% - 90%	High functional group tolerance; late-stage utility.
Cu-Catalyzed Cross-Coupling	CuCl (cat.), Diaryliodonium salts	Complete N(2)-control	70% - 98%	Direct use of 1H-indazoles without pre-functionalization.

Conclusion

The synthesis of 2H-indazoles has transitioned from brute-force thermodynamic cyclizations to highly orchestrated, mechanistically driven catalytic cascades. By understanding the causality of these reactions—whether it be the nucleophilic trapping in the Cadogan reaction, the exergonic nitrogen extrusion in MCRs, or the directing-group capabilities in C-H activation—researchers can predictably design and scale complex indazole-based therapeutics.

References

- Regioselective Synthesis of 2H-Indazoles Using a Mild, One-Pot Condensation–Cadogan Reductive Cyclization Organic Letters - ACS Publications[[Link](#)][2]
- Rhodium(III)-Catalyzed Indazole Synthesis by C–H Bond Functionalization and Cyclative Capture PMC - National Institutes of Health (NIH)[[Link](#)][4]
- Access to 2-substituted-2H-indazoles via a copper-catalyzed regioselective cross-coupling reaction Organic & Biomolecular Chemistry (RSC Publishing)[[Link](#)][5]
- Consecutive Condensation, C–N and N–N Bond Formations: A Copper-Catalyzed One-Pot Three-Component Synthesis of 2H-Indazole Organic Letters - ACS Publications[[Link](#)]
- Accessing Multiple Classes of 2H-Indazoles: Mechanistic Implications for the Cadogan and Davis-Beirut Reactions PMC - National Institutes of Health (NIH)[[Link](#)][1]

Need Custom Synthesis?

BenchChem offers custom synthesis for rare earth carbides and specific isotopic labeling.

Email: info@benchchem.com or [Request Quote Online](#).

Sources

- 1. Accessing Multiple Classes of 2H-Indazoles: Mechanistic Implications for the Cadogan and Davis-Beirut Reactions - PMC [[pmc.ncbi.nlm.nih.gov](https://pubmed.ncbi.nlm.nih.gov/)]
- 2. pubs.acs.org [pubs.acs.org]
- 3. pdf.benchchem.com [pdf.benchchem.com]
- 4. Rhodium(III)-Catalyzed Indazole Synthesis by C–H Bond Functionalization and Cyclative Capture - PMC [[pmc.ncbi.nlm.nih.gov](https://pubmed.ncbi.nlm.nih.gov/)]
- 5. Access to 2-substituted-2H-indazoles via a copper-catalyzed regioselective cross-coupling reaction - Organic & Biomolecular Chemistry (RSC Publishing) [pubs.rsc.org]
- To cite this document: BenchChem. [Advanced Methodologies in 2H-Indazole Synthesis: A Comprehensive Technical Guide]. BenchChem, [2026]. [Online PDF]. Available at: [<https://www.benchchem.com/product/b11717422/docs#advanced-methodologies-in-2h-indazole-synthesis-a-comprehensive-technical-guide>]

Disclaimer & Data Validity:

The information provided in this document is for Research Use Only (RUO) and is strictly not intended for diagnostic or therapeutic procedures. While BenchChem strives to provide accurate protocols, we make no warranties, express or implied, regarding the fitness of this product for every specific experimental setup.

Technical Support: The protocols provided are for reference purposes. Unsure if this reagent suits your experiment?

Need Industrial/Bulk Grade? [Request Custom Synthesis Quote](#)

BenchChem

Our mission is to be the trusted global source of essential and advanced chemicals, empowering scientists and researchers to drive progress in science and industry.

Contact

Address: 3281 E Guasti Rd
Ontario, CA 91761, United States
Phone: (601) 213-4426
Email: info@benchchem.com

[Contact our Ph.D. Support Team for a compatibility check](#)