

Technical Support Center: Troubleshooting Side Reactions in the Bromination of Chalcones

Author: BenchChem Technical Support Team. **Date:** April 2026

Compound of Interest

Compound Name: *1,3-Dibromo-1,3-diphenyl-2-propanone*

CAS No.: 958-79-2

Cat. No.: B11715415

[Get Quote](#)

Welcome to the technical support center for the bromination of chalcones. This guide is designed for researchers, scientists, and professionals in drug development who are encountering challenges with this common but nuanced reaction. Here, we will delve into the complexities of chalcone bromination, with a specific focus on troubleshooting and preventing unwanted nucleophilic substitution side reactions. Our approach is rooted in a deep understanding of the underlying reaction mechanisms to empower you to make informed decisions in your experimental design.

Frequently Asked Questions (FAQs)

Q1: What is the primary, desired reaction when brominating a chalcone?

The principal reaction is the electrophilic addition of bromine across the α,β -unsaturated double bond of the chalcone scaffold.^[1] This reaction proceeds via a cyclic bromonium ion intermediate, which is subsequently attacked by a bromide ion in an anti-addition fashion to

yield the α,β -dibromo derivative.[1] This dibrominated product is often a key intermediate in the synthesis of various heterocyclic compounds.[1]

Q2: I've observed the formation of multiple products in my reaction. What is the most common side reaction?

The most prevalent side reaction during the bromination of chalcones is electrophilic aromatic substitution, also known as nuclear bromination.[2] This occurs when the bromine reacts with one or both of the aromatic rings of the chalcone, in addition to or instead of the desired addition to the double bond.

Q3: Why does nuclear bromination occur, and what factors promote it?

Nuclear bromination is a competing electrophilic reaction. Its occurrence is highly dependent on the electronic properties of the chalcone's aromatic rings and the reaction conditions. The key factors include:

- **Electron-Donating Groups (EDGs):** Substituents such as hydroxyl (-OH), methoxy (-OCH₃), or alkyl groups on the aromatic rings increase the electron density of the rings, making them more nucleophilic and thus more susceptible to electrophilic attack by bromine.[3][4] These groups are known as "activating groups" and direct bromination to the ortho and para positions.[3][4]
- **Harsh Brominating Agents:** Stronger brominating agents or conditions that generate a more potent electrophilic bromine species can favor nuclear substitution.
- **Presence of Lewis or Brønsted Acids:** While Lewis acids can sometimes be used to promote specific reactions, they can also activate the brominating agent and the aromatic ring, potentially leading to increased nuclear substitution.[5] Conversely, Brønsted acids can also promote ring bromination.[5]
- **Reaction Temperature:** Higher reaction temperatures can provide the necessary activation energy for the typically less favored nuclear substitution to occur.

Troubleshooting Guide: Suppressing Nuclear Bromination

This section provides a structured approach to diagnosing and resolving issues with unwanted nuclear substitution.

Issue 1: My chalcone has electron-donating groups, and I'm observing significant nuclear bromination.

Causality: The electron-rich aromatic rings are competing with the double bond for the electrophilic bromine.

Solutions:

- Choice of Brominating Agent:
 - Avoid Molecular Bromine (Br_2): While a classic reagent, Br_2 can be harsh and lead to a mixture of products, especially with activated systems.[6]
 - Utilize N-Bromosuccinimide (NBS): NBS is generally a milder and more selective source of electrophilic bromine for addition reactions.[2][6] However, under certain conditions (e.g., acid catalysis), it can also lead to nuclear bromination.[7]
 - Employ Tetrabutylammonium Tribromide (TBATB): TBATB is a stable, solid reagent that often provides high yields of the desired dibromo adduct with good selectivity, even in solvent-free conditions.[8][9]
- Solvent and Temperature Control:
 - Non-polar Solvents: Using less polar solvents can sometimes temper the reactivity of the brominating agent.
 - Low Temperature: Perform the reaction at 0°C or below to minimize the rate of the competing nuclear substitution reaction.
- Protecting Groups:

- For highly activated systems, particularly those with phenol or aniline moieties, consider protecting the activating group (e.g., as an acetate or a tosylate) before bromination. The protecting group can be removed in a subsequent step.

Issue 2: My reaction is sluggish, and upon forcing conditions (e.g., heating), I get a complex mixture of products.

Causality: The chalcone may be deactivated, or the reaction conditions are not optimal, leading to side reactions upon heating.

Solutions:

- Catalyst Selection:
 - Lewis Acid Catalysis: For some substrates, a Lewis acid catalyst can selectively activate the α,β -unsaturated system for addition. However, care must be taken as Lewis acids can also promote nuclear substitution.^[5] A screening of different Lewis acids (e.g., ZnCl_2 , InCl_3) at catalytic amounts may be necessary.
 - Avoid Brønsted Acids: Brønsted acids are more likely to promote electrophilic aromatic substitution.^[5]
- Alternative Bromination Methods:
 - In situ Generation of Bromine: Using systems like $\text{H}_2\text{O}_2/\text{HBr}$ can provide a controlled, low concentration of bromine, which can improve selectivity.

Mechanistic Insights: Addition vs. Substitution

To effectively troubleshoot, it's crucial to understand the competing reaction pathways.

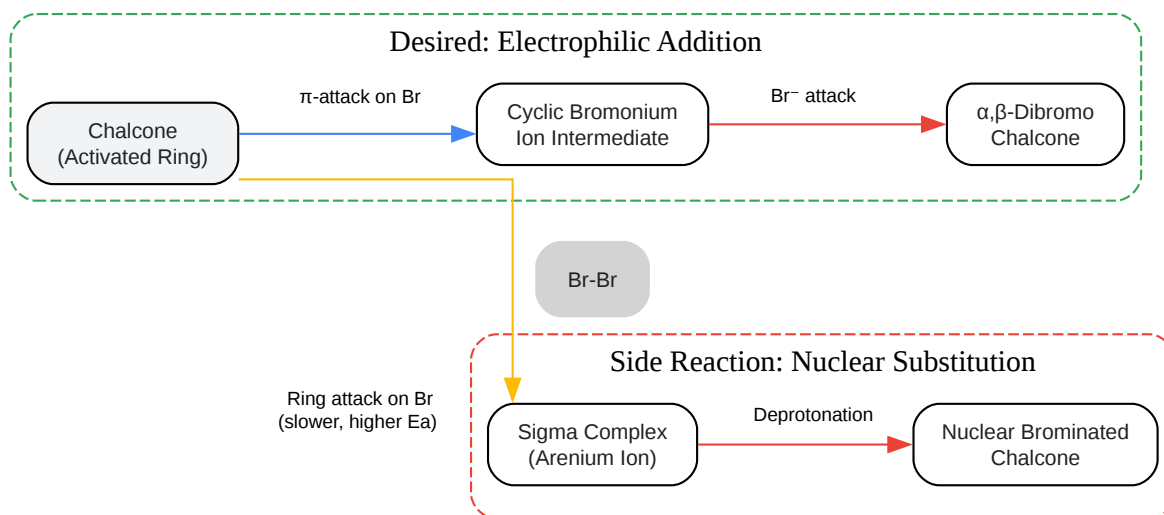

[Click to download full resolution via product page](#)

Caption: Competing pathways in chalcone bromination.

The desired electrophilic addition to the double bond is generally faster and has a lower activation energy than electrophilic aromatic substitution.^[10] However, when the aromatic ring is highly activated by electron-donating groups, the energy barrier for the formation of the sigma complex (arenium ion) is lowered, making it a more competitive pathway.

Experimental Protocols

Protocol 1: Selective Bromination using Tetrabutylammonium Tribromide (TBATB) under Solvent-Free Conditions

This method is often highly selective for the double bond and is environmentally friendly.

Procedure:

- In a mortar, combine the chalcone (1 mmol) and TBATB (1 mmol).

- Grind the mixture with a pestle at room temperature for 10-15 minutes. The progress of the reaction can be monitored by Thin Layer Chromatography (TLC).
- Upon completion, add 20 mL of water to the reaction mixture and stir for 10 minutes to dissolve the tetrabutylammonium bromide byproduct.
- Filter the solid product, wash thoroughly with water, and air-dry to obtain the α,β -dibromochalcone.[8]
- The product can be further purified by recrystallization from a suitable solvent like ethanol.

Protocol 2: Bromination with N-Bromosuccinimide (NBS) in Acetic Acid

A common method that requires careful control of conditions to avoid side reactions.

Procedure:

- Dissolve the chalcone (1 mmol) in glacial acetic acid (5-10 mL) in a round-bottom flask equipped with a magnetic stirrer.
- Cool the solution to 0°C in an ice bath.
- Add NBS (1.05 mmol) portion-wise over 10-15 minutes, ensuring the temperature remains low.
- Stir the reaction at 0°C for 1-2 hours, monitoring by TLC.
- Once the starting material is consumed, pour the reaction mixture into cold water.
- Collect the precipitated product by filtration, wash with water until neutral, and dry.
- Recrystallize from a suitable solvent if necessary.

Data Summary: Influence of Reaction Conditions

The following table summarizes the expected outcomes based on different experimental parameters.

Brominating Agent	Chalcone Substituents	Conditions	Expected Major Product	Potential Side Products
Br ₂ in CHCl ₃	Unsubstituted	0°C to RT	α,β-Dibromo chalcone	Minor nuclear bromination
Br ₂ in Acetic Acid	Electron-donating (e.g., -OCH ₃)	RT to 70°C	Mixture	Significant nuclear bromination
NBS in Acetonitrile	Electron-donating	RT	α,β-Dibromo chalcone	Nuclear bromination
TBATB	Electron-donating	Solvent-free, RT	α,β-Dibromo chalcone	Minimal to no nuclear bromination

Characterization of Byproducts

Identifying the presence of nuclear brominated byproducts is crucial for reaction optimization.

- ¹H NMR Spectroscopy: Look for changes in the aromatic region. The introduction of a bromine atom will alter the splitting patterns and chemical shifts of the aromatic protons. The characteristic doublets for the α and β protons of the chalcone double bond will be absent in the dibromo adduct, replaced by signals at a different chemical shift.
- Mass Spectrometry: The mass spectrum will show a characteristic isotopic pattern for bromine-containing compounds (¹⁹Br and ⁸¹Br are in an approximate 1:1 ratio). Multiple bromine atoms will result in a more complex isotopic pattern.

Concluding Remarks

The successful bromination of chalcones hinges on a careful consideration of the substrate's electronic properties and the selection of appropriate reaction conditions. By understanding the mechanistic competition between electrophilic addition and aromatic substitution, researchers can effectively troubleshoot and optimize their synthetic protocols to achieve high yields of the desired dibrominated products while minimizing unwanted side reactions.

References

- Zhang, S., et al. (2017). A new brominated chalcone derivative suppresses the growth of gastric cancer cells in vitro and in vivo involving ROS mediated up-regulation of DR5 and 4 expression and apoptosis. PMC. [[Link](#)]
- Adokar, M. R. (2013). synthesis and green bromination of some chalcones and their antimicrobial screening. ResearchGate. [[Link](#)]
- Abreu, A. S., et al. (2022). Macroalgae-Inspired Brominated Chalcones as Cosmetic Ingredients with the Potential to Target Skin Inflammaging. PMC. [[Link](#)]
- Chemistry LibreTexts. (2022). 16.1: Electrophilic Aromatic Substitution Reactions - Bromination. [[Link](#)]
- Jardine, A., et al. (2021). BDDE-Inspired Chalcone Derivatives to Fight Bacterial and Fungal Infections. PMC. [[Link](#)]
- Ahamad, J., Khatua, R. R., & Khan, F. A. (2025). Lewis acid-promoted intramolecular cyclization of ortho-prenylated chalcones: application to first total synthesis of (\pm) involucrasin C and its novel analogues. RSC Publishing. [[Link](#)]
- Reddit. (2019). Trouble with NBS bromination. [[Link](#)]
- Wikipedia. (n.d.). N-Bromosuccinimide. [[Link](#)]
- Wei, Y., Lin, S., Liang, F., & Zhang, J. (2013). N-Bromosuccinimide/1,8-Diazabicyclo[5.4.1]undec-7-ene Combination: β -Amination of Chalcones via a Tandem Bromoamination/Debromination Sequence. Organic Letters, 15(4), 848–851. [[Link](#)]
- Haji, D. G., & Omer, K. M. (2024). Bromination of Chalcone: A Study on Synthesis, Characterization, and Optoelectronic Properties. Koya University Eprints. [[Link](#)]
- Cera, G., et al. (2025). Chalcone Synthesis by Green Claisen–Schmidt Reaction in Cationic and Nonionic Micellar Media. The Journal of Organic Chemistry. [[Link](#)]
- de Oliveira, A. C. S., et al. (2022). Synthesis, Molecular Structure, Thermal and Spectroscopic Analysis of a Novel Bromochalcone Derivative with Larvicidal Activity. MDPI.

[\[Link\]](#)

- Morsch, L., et al. (n.d.). 10.10. Regioselectivity and Substituent Effects. In Introduction to Organic Chemistry. [\[Link\]](#)
- Ashenhurst, J. (2017). Electrophilic Aromatic Substitution Mechanism. Master Organic Chemistry. [\[Link\]](#)
- Abdel-Wahab, B. F., et al. (2024). Variation of the bromination site on the reaction of (E)-1-[5-methyl-1-(aryl)-1H-1,2,3-triazol-4-yl]-3-arylprop-2-en-1-ones with N-bromosuccinimide. ResearchGate. [\[Link\]](#)
- Haji, D. G., & Omer, K. M. (2024). Bromination of Chalcone: A Study on Synthesis, Characterization, and Optoelectronic Properties. ResearchGate. [\[Link\]](#)
- Pereira, C., et al. (2022). The green chemistry of chalcones: Valuable sources of privileged core structures for drug discovery. Frontiers. [\[Link\]](#)
- Organic Chemistry Portal. (n.d.). N-Bromosuccinimide (NBS). [\[Link\]](#)
- Al-Hadiya, B., et al. (2016). The Role of Chalcones in Suppression of NF-κB-Mediated Inflammation and Cancer. PMC. [\[Link\]](#)
- Chiba, S., & Narasaka, K. (2012). Lewis Acid Catalyzed Benzylic Bromination. PMC. [\[Link\]](#)
- ARO-THE SCIENTIFIC JOURNAL OF KOYA UNIVERSITY. (2024). Bromination of Chalcone: A Study on Synthesis, Characterization, and Optoelectronic Properties. [\[Link\]](#)
- ScholarWorks at WMU. (n.d.). Synthesis of Biologically Active Substituted Chalcones. [\[Link\]](#)
- Google Patents. (n.d.).
- Wang, Y., et al. (2015). Regioselective Electrophilic Aromatic Bromination: Theoretical Analysis and Experimental Verification. PMC. [\[Link\]](#)
- ResearchGate. (2025). (PDF) Reaction of Chalcones with Cellular Thiols. The Effect of the 4-Substitution of Chalcones and Protonation State of the Thiols on the Addition Process. Diastereoselective Thiol Addition. [\[Link\]](#)

- Aswini, R., & Kothai, S. (2021). A Study on the Synthesis, Characterisation of Chalcone moiety. Jetir.Org. [[Link](#)]

Need Custom Synthesis?

BenchChem offers custom synthesis for rare earth carbides and specific isotopic labeling.

Email: info@benchchem.com or [Request Quote Online](#).

Sources

- 1. [benchchem.com](https://www.benchchem.com) [[benchchem.com](https://www.benchchem.com)]
- 2. A new brominated chalcone derivative suppresses the growth of gastric cancer cells in vitro and in vivo involving ROS mediated up-regulation of DR5 and 4 expression and apoptosis - PMC [[pmc.ncbi.nlm.nih.gov](https://pubmed.ncbi.nlm.nih.gov/)]
- 3. 10.10. Regioselectivity and Substituent Effects – Introduction to Organic Chemistry [[saskoer.ca](https://www.saskoer.ca)]
- 4. Regioselective Electrophilic Aromatic Bromination: Theoretical Analysis and Experimental Verification - PMC [[pmc.ncbi.nlm.nih.gov](https://pubmed.ncbi.nlm.nih.gov/)]
- 5. Lewis Acid Catalyzed Benzylic Bromination - PMC [[pmc.ncbi.nlm.nih.gov](https://pubmed.ncbi.nlm.nih.gov/)]
- 6. BDDE-Inspired Chalcone Derivatives to Fight Bacterial and Fungal Infections - PMC [[pmc.ncbi.nlm.nih.gov](https://pubmed.ncbi.nlm.nih.gov/)]
- 7. N-Bromosuccinimide - Wikipedia [en.wikipedia.org]
- 8. [researchgate.net](https://www.researchgate.net) [[researchgate.net](https://www.researchgate.net)]
- 9. eprints.koyauniversity.org [eprints.koyauniversity.org]
- 10. chem.libretexts.org [chem.libretexts.org]
- To cite this document: BenchChem. [Technical Support Center: Troubleshooting Side Reactions in the Bromination of Chalcones]. BenchChem, [2026]. [Online PDF]. Available at: [<https://www.benchchem.com/product/b11715415/docs#technical-support-center-troubleshooting-side-reactions-in-the-bromination-of-chalcones>]

Disclaimer & Data Validity:

The information provided in this document is for Research Use Only (RUO) and is strictly not intended for diagnostic or therapeutic procedures. While BenchChem strives to provide accurate protocols, we make no warranties, express or implied, regarding the fitness of this product for every specific experimental setup.

Technical Support: The protocols provided are for reference purposes. Unsure if this reagent suits your experiment?

Need Industrial/Bulk Grade? [Request Custom Synthesis Quote](#)

BenchChem

Our mission is to be the trusted global source of essential and advanced chemicals, empowering scientists and researchers to drive progress in science and industry.

Contact

Address: 3281 E Guasti Rd
Ontario, CA 91761, United States
Phone: (601) 213-4426
Email: info@benchchem.com

[Contact our Ph.D. Support Team for a compatibility check](#)