

# Application Note: Advanced Synthesis of Pyrazole Derivatives for Drug Discovery[1][2]

**Author:** BenchChem Technical Support Team. **Date:** April 2026

## Compound of Interest

Compound Name: *(E)-N'-hydroxy-3-(1H-pyrazol-1-yl)butanimidamide*

Cat. No.: B11714221

[Get Quote](#)

## Introduction: The Pyrazole Pharmacophore

The pyrazole ring is a "privileged structure" in medicinal chemistry, serving as the core scaffold for blockbuster drugs like Celecoxib (COX-2 inhibitor), Ruxolitinib (JAK inhibitor), and Sildenafil (PDE5 inhibitor).[1][2] Its planar, electron-rich architecture allows for diverse non-covalent interactions—hydrogen bonding via the unsubstituted nitrogen (

-H) and

-stacking interactions.

However, the synthesis of pyrazoles presents a classic challenge in organic chemistry: Regioselectivity.[3] Traditional condensation methods often yield mixtures of regioisomers (1,3- vs. 1,5-substituted), which are difficult to separate and possess vastly different biological activities.

This Application Note moves beyond basic textbook definitions to provide three field-proven protocols:

- Classical Knorr Synthesis (optimized for scale).

- Regioselective [3+2] Cycloaddition (for precision library generation).
- Late-Stage C-H Functionalization (for rapid SAR exploration).

## Strategic Synthesis Planning

Before selecting a protocol, the chemist must analyze the target substitution pattern. The choice of method is dictated by the availability of starting materials and the tolerance for isomeric mixtures.

### Diagram 1: Pyrazole Retrosynthetic Decision Tree

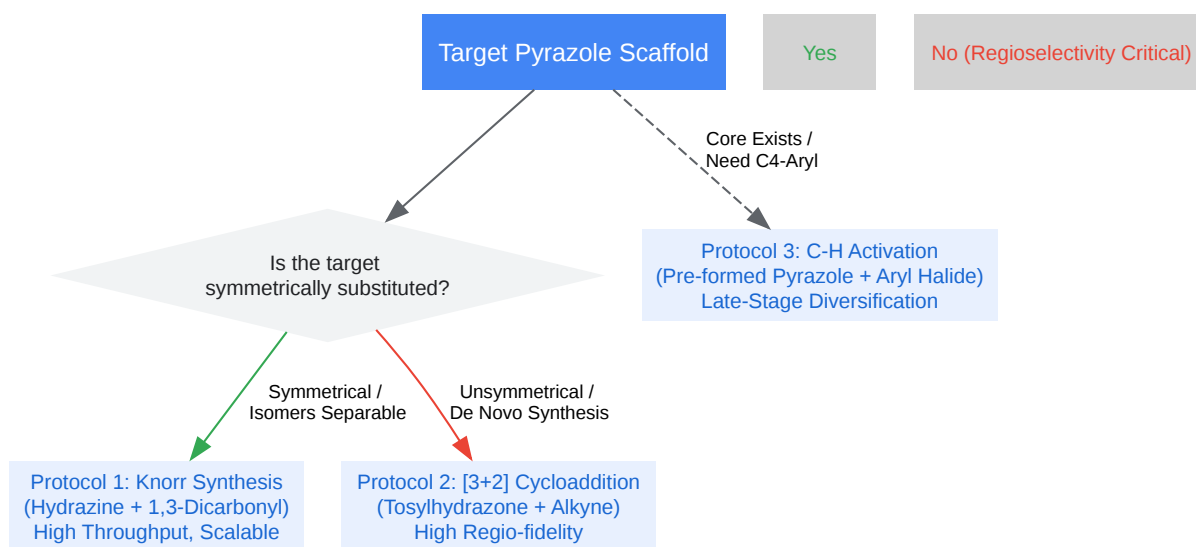

[Click to download full resolution via product page](#)

Caption: Strategic decision tree for selecting the optimal pyrazole synthesis pathway based on substrate symmetry and stage of discovery.

## Protocol 1: Classical Knorr Condensation (Optimized)

Application: Large-scale synthesis of simple pyrazoles or when regioisomers are easily separable by crystallization.

Principle: The condensation of hydrazine derivatives with 1,3-dicarbonyl compounds.[4][5][6][7][8][9][10] Critical Insight: The reaction proceeds via a hydrazone intermediate.[8] The regioselectivity is governed by the relative electrophilicity of the carbonyl carbons and the nucleophilicity of the hydrazine nitrogens.

## Materials

- Substrate: 1-Phenylbutane-1,3-dione (1.0 equiv)
- Reagent: Methylhydrazine (1.1 equiv)
- Solvent: Ethanol (Absolute) or Methanol
- Catalyst: Glacial Acetic Acid (cat. 5 mol%)

## Step-by-Step Methodology

- Setup: Charge a round-bottom flask with 1-phenylbutane-1,3-dione (10 mmol) and Ethanol (20 mL).
- Addition: Cool the solution to 0°C. Add Methylhydrazine (11 mmol) dropwise over 10 minutes.
  - Note: Exothermic reaction. Control temp to prevent immediate uncontrolled cyclization.
- Catalysis: Add Glacial Acetic Acid (0.5 mmol).
- Reflux: Heat the mixture to reflux (78°C) for 2–4 hours. Monitor by TLC (EtOAc/Hexane 3:7). [8]
- Workup:
  - Cool to room temperature.
  - Concentrate under reduced pressure to remove ethanol.
  - Dissolve residue in EtOAc, wash with water and brine.
  - Dry over

and concentrate.

- Purification (The Isomer Challenge):
  - The crude will contain a mixture of 1,3-dimethyl-5-phenylpyrazole and 1,5-dimethyl-3-phenylpyrazole.
  - Separation: Use flash column chromatography.<sup>[7][11]</sup> The 1,5-isomer is typically less polar due to steric shielding of the lone pair by the phenyl ring.

Table 1: Troubleshooting Knorr Regioselectivity

| Observation            | Root Cause                            | Corrective Action                                       |
|------------------------|---------------------------------------|---|
| 1:1 Mixture of Isomers | Similar electrophilicity of carbonyls | Switch to Protocol 2 (Cycloaddition) for control.       |
| Low Yield              | Retro-Claisen condensation            | Avoid strong bases; use mild acid catalysis (AcOH).     |
| Oiling out             | Product aggregation                   | Induce crystallization by adding cold pentane or ether. |

## Protocol 2: Regioselective Synthesis via [3+2] Cycloaddition

Application: Synthesis of 1,3,5-trisubstituted pyrazoles with complete regiocontrol.<sup>[10][12]</sup> Ideal for SAR library generation.

Principle: This protocol utilizes in situ generation of diazo compounds from

-tosylhydrazones, followed by a copper-catalyzed [3+2] cycloaddition with terminal alkynes. This avoids handling potentially explosive isolated diazo species.

### Diagram 2: Regioselective Mechanism

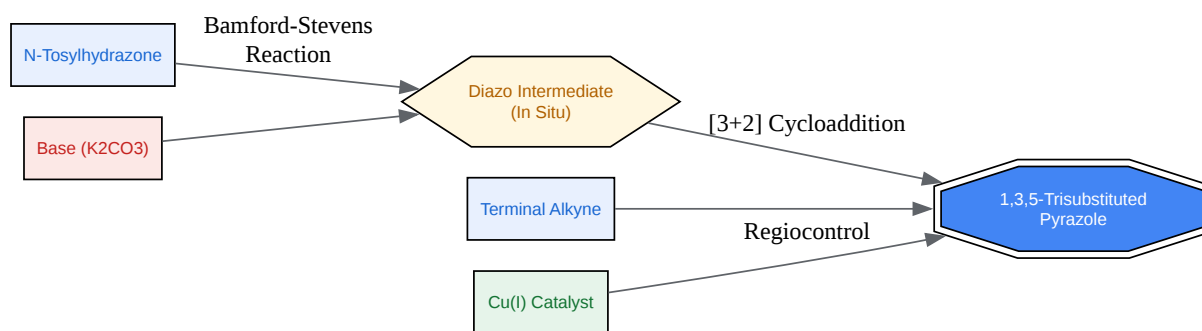

[Click to download full resolution via product page](#)

Caption: Pathway for the copper-catalyzed regioselective synthesis of pyrazoles from tosylhydrazones.

## Materials

- Substrate A: Aryl aldehyde  
-tosylhydrazone (1.0 equiv)
- Substrate B: Phenylacetylene (1.2 equiv)
- Catalyst: CuI (10 mol%)
- Base:  
(2.0 equiv)
- Solvent: 1,4-Dioxane (0.2 M)

## Step-by-Step Methodology

- Preparation: In a dry screw-cap vial, combine the  
-tosylhydrazone (0.5 mmol), phenylacetylene (0.6 mmol), CuI (0.05 mmol), and  
(1.0 mmol).

- Solvation: Add anhydrous 1,4-Dioxane (2.5 mL). Flush with Argon.
- Reaction: Heat the sealed vial to 110°C for 12 hours.
  - Mechanism:<sup>[5][9][10][12]</sup> The base decomposes the hydrazone to a diazo species. The Cu catalyst coordinates the alkyne, directing the diazo attack to the terminal carbon, ensuring 1,3,5-substitution.
- Workup: Filter the hot mixture through a Celite pad to remove inorganic salts. Wash the pad with EtOAc.
- Purification: Concentrate the filtrate. Purify via silica gel chromatography (Hexane/EtOAc gradient).
  - Result: Typically >95:5 regioselectivity favoring the 1,3,5-isomer.

## Protocol 3: Late-Stage C-H Functionalization

Application: Rapidly diversifying the C-4 position of an existing pyrazole core (e.g., "Scaffold Hopping").

Principle: Palladium-catalyzed direct C-H arylation. The C-4 position of the pyrazole ring is nucleophilic (similar to the C-3 of indole) and susceptible to electrophilic palladation.

## Materials

- Substrate: 1-Methyl-1H-pyrazole (1.0 equiv)
- Coupling Partner: Aryl Bromide (1.5 equiv)
- Catalyst:  
(5 mol%)
- Ligand:  
(10 mol%)
- Base:

(2.0 equiv)

- Acid Additive: Pivalic acid (30 mol%) - Crucial for C-H activation step (CMD mechanism).
- Solvent: Toluene

## Step-by-Step Methodology

- Charge: In a glovebox or under strict flow, combine  
  
, Phosphine ligand,  
  
, and Pivalic acid in a pressure tube.
- Add Reactants: Add the pyrazole substrate and Aryl Bromide. Add Toluene (degassed).
- Heat: Seal the tube and heat to 110°C for 16–24 hours.
  - Note: Pivalic acid acts as a proton shuttle, lowering the energy barrier for the C-H bond cleavage.
- Workup: Dilute with EtOAc, wash with  
  
(aq) to remove the acid.
- Analysis: The product will be the C-4 arylated pyrazole. If C-5 arylation is observed, it indicates a switch in mechanism (often due to acidity of C-5 proton), but under these conditions, C-4 is kinetically favored for electron-rich pyrazoles.

## Characterization & Data Reporting

Proper characterization is mandatory for publication and patent filing.

Table 2: Key NMR Signatures for Regioisomer Identification

| Position       | 1,3-Disubstituted (Isomer A)              | 1,5-Disubstituted (Isomer B)                        |
|----------------|---|---|
| C-4 Proton ( ) | Typically 6.6 – 6.8 ppm                   | Typically 6.3 – 6.5 ppm (Shielded by N-substituent) |
| NOESY Signal   | Strong NOE between -Methyl and C-5 Proton | Strong NOE between -Methyl and C-5 Substituent      |
| C-13 NMR ( )   | C-3 is generally downfield                | C-5 is generally upfield due to N-lone pair overlap |

## References

- Knorr, L. (1883).[1][9] Einwirkung von Acetessigester auf Phenylhydrazin.[9] Berichte der deutschen chemischen Gesellschaft, 16(2), 2597–2599.[9]
- Kong, Y., Tang, M., & Wang, Y. (2014).[10][12] Regioselective Synthesis of 1,3,5-Trisubstituted Pyrazoles from N-Alkylated Tosylhydrazones and Terminal Alkynes. Organic Letters, 16(2), 576–579.[12]
- Joerger, A. C., et al. (2020). Transition-metal-catalyzed C–H functionalization of pyrazoles. Organic & Biomolecular Chemistry, 18, 6192-6210.
- BenchChem Technical Guides. (2025). Identifying and removing byproducts in pyrazole synthesis.
- Fustero, S., et al. (2010). Recent Advances in the Synthesis of Pyrazoles. A Review. Organic Preparations and Procedures International, 42(5), 419-473.

### Need Custom Synthesis?

BenchChem offers custom synthesis for rare earth carbides and specific isotopic labeling.

Email: [info@benchchem.com](mailto:info@benchchem.com) or [Request Quote Online](#).

## Sources

- [1. chemrevlett.com](https://chemrevlett.com) [chemrevlett.com]
- [2. researchgate.net](https://researchgate.net) [researchgate.net]
- [3. orgsyn.org](https://orgsyn.org) [orgsyn.org]
- [4. Knorr Pyrazole Synthesis \(Chapter 32\) - Name Reactions in Organic Synthesis](#) [cambridge.org]
- [5. mdpi.com](https://mdpi.com) [mdpi.com]
- [6. pdf.benchchem.com](https://pdf.benchchem.com) [pdf.benchchem.com]
- [7. pdf.benchchem.com](https://pdf.benchchem.com) [pdf.benchchem.com]
- [8. chemhelpasap.com](https://chemhelpasap.com) [chemhelpasap.com]
- [9. jk-sci.com](https://jk-sci.com) [jk-sci.com]
- [10. Pyrazole synthesis](https://organic-chemistry.org) [organic-chemistry.org]
- [11. researchgate.net](https://researchgate.net) [researchgate.net]
- [12. Regioselective Synthesis of 1,3,5-Trisubstituted Pyrazoles from N-Alkylated Tosylhydrazones and Terminal Alkynes](https://organic-chemistry.org) [organic-chemistry.org]
- To cite this document: BenchChem. [Application Note: Advanced Synthesis of Pyrazole Derivatives for Drug Discovery[1][2]]. BenchChem, [2026]. [Online PDF]. Available at: [https://www.benchchem.com/product/b11714221/docs#application-note-advanced-synthesis-of-pyrazole-derivatives-for-drug-discovery-1-2]

---

### Disclaimer & Data Validity:

The information provided in this document is for Research Use Only (RUO) and is strictly not intended for diagnostic or therapeutic procedures. While BenchChem strives to provide accurate protocols, we make no warranties, express or implied, regarding the fitness of this product for every specific experimental setup.

**Technical Support:** The protocols provided are for reference purposes. Unsure if this reagent suits your experiment?

**Need Industrial/Bulk Grade?** [Request Custom Synthesis Quote](#)

# BenchChem

Our mission is to be the trusted global source of essential and advanced chemicals, empowering scientists and researchers to drive progress in science and industry.

## Contact

Address: 3281 E Guasti Rd

Ontario, CA 91761, United States

Phone: (601) 213-4426

Email: [info@benchchem.com](mailto:info@benchchem.com)

[Contact our Ph.D. Support Team for a compatibility check](#)