

# Application Note: Functionalization of the 2-Position in 1,3-Dithiepins

**Author:** BenchChem Technical Support Team. **Date:** May 2026

## Compound of Interest

Compound Name:	<i>Dibenzod,f1,3dithiepin, 4,8-dimethyl-</i>
CAS No.:	190841-59-9
Cat. No.:	B1170836

[Get Quote](#)

## Executive Summary & Strategic Rationale

While 1,3-dithianes (6-membered rings) are the ubiquitous workhorses of acyl anion chemistry (Umpolung), 1,3-dithiepins (7-membered rings) and their 4,7-dihydro derivatives offer unique steric and electronic advantages in complex synthesis.<sup>[1][2]</sup> The 2-position of the 1,3-dithiepin ring is flanked by two sulfur atoms, rendering the C2-proton acidic (pKa ~31-32).<sup>[1][2]</sup> However, unlike the rigid chair conformation of dithianes, the 1,3-dithiepin ring adopts a flexible twist-boat conformation.<sup>[2]</sup>

Why use 1,3-dithiepins?

- **Modulated Reactivity:** The 7-membered ring exhibits different hydrolytic stability profiles compared to dithianes, often requiring specific oxidative conditions for deprotection, which allows for orthogonal protection strategies.<sup>[2]</sup>
- **Masked cis-Butenedial:** The 4,7-dihydro-1,3-dithiepin framework serves as a stable equivalent for cis-2-butene-1,4-dial, a reactive intermediate in furan and natural product

synthesis.[1]

- Steric Differentiation: The larger bite angle of the S-C-S linkage in the 7-membered ring creates a distinct steric pocket, influencing the stereoselectivity of electrophilic attack at C2. [2]

This guide details the protocols for direct C2-lithiation and electrophilic trapping, addressing the specific stability challenges posed by the 7-membered ring system.

## Mechanistic Principles & Conformational Analysis

### The Challenge of Ring Flexibility

Unlike 1,3-dithianes, which lock into a chair conformation placing the C2-lithium species in a defined equatorial or axial orientation, 1,3-dithiepins exist in a dynamic equilibrium.[1][2]

- Conformation: The twist-boat is the ground state.[2][3]
- Anion Stability: The C2-lithio species is less thermodynamically stable than its dithiane counterpart due to transannular interactions and ring strain.[2][3]
- Implication: Lithiation requires strictly controlled cryogenic conditions (-78 °C) and often the use of polar additives (TMEDA, HMPA) to stabilize the monomeric organolithium species and prevent decomposition (e.g., via -elimination or fragmentation).[1][2]

## Pathway Logic

The functionalization follows the Corey-Seebach Umpolung logic:

- Deprotonation: Removal of the C2 proton by a strong base (n-BuLi).[2][3]
- Stabilization: The resulting carbanion is stabilized by the empty d-orbitals (or orbitals) of the two adjacent sulfur atoms.[2][3]
- Trapping: Reaction with an electrophile ( ) generates the 2-substituted derivative.

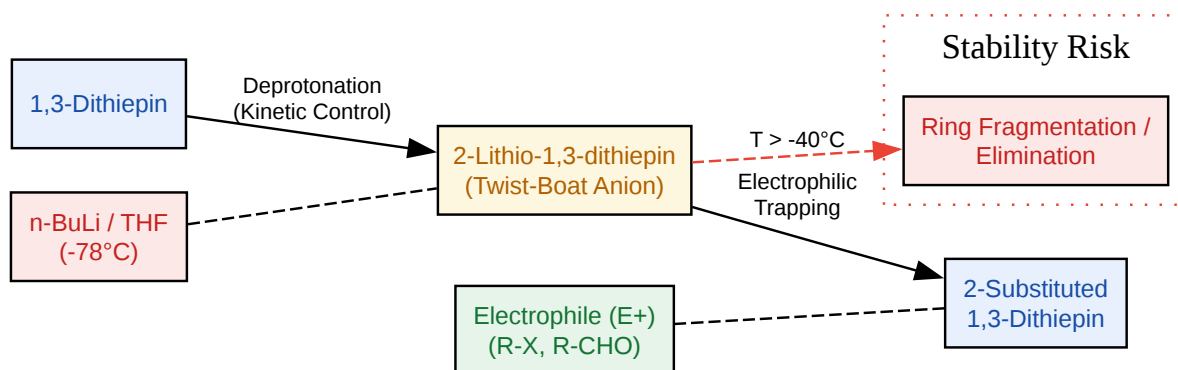

[Click to download full resolution via product page](#)

Figure 1: Reaction pathway for C2 functionalization. Note the critical temperature threshold to avoid ring fragmentation.[2][3]

## Experimental Protocols

### Protocol A: Direct Lithiation and Alkylation of 4,7-Dihydro-1,3-dithiepin

Best for: Introducing alkyl groups or reacting with carbonyls when the dithiepin ring is already formed.[1]

Reagents:

- Substrate: 4,7-Dihydro-1,3-dithiepin (1.0 equiv)[1]
- Base: n-Butyllithium (1.1 equiv, 2.5 M in hexanes)[1][2]
- Additive: TMEDA (N,N,N',N'-tetramethylethylenediamine) (1.1 equiv) – Crucial for breaking Li-aggregates and stabilizing the anion.[1][2]
- Solvent: Anhydrous THF (0.2 M concentration wrt substrate)
- Electrophile: Alkyl halide or Aldehyde (1.2 equiv)[1][2]

Step-by-Step Procedure:

- Setup: Flame-dry a 2-neck round-bottom flask equipped with a magnetic stir bar, nitrogen inlet, and rubber septum. Flush with  
  
for 15 minutes.
- Solvation: Add anhydrous THF and the 4,7-dihydro-1,3-dithiepin substrate via syringe.
- Cooling: Cool the solution to -78 °C using a dry ice/acetone bath. Allow 15 minutes for thermal equilibration.
- Base Addition: Add TMEDA followed by the dropwise addition of n-BuLi over 10 minutes.
  - Note: The solution typically turns a pale yellow/orange color, indicating anion formation.<sup>[2]</sup>  
<sup>[3]</sup>
- Anion Maturation: Stir at -78 °C for 1 hour.
  - Critical: Do NOT allow the temperature to rise above -40 °C, as the 7-membered ring anion is prone to decomposition.<sup>[1]</sup><sup>[2]</sup>
- Electrophile Trapping: Add the electrophile (neat or dissolved in minimal THF) dropwise.<sup>[2]</sup><sup>[3]</sup>
  - For Aldehydes: The color usually fades immediately.<sup>[2]</sup><sup>[3]</sup>
  - For Alkyl Halides: Stirring for 2–4 hours at -78 °C may be required.<sup>[1]</sup><sup>[2]</sup><sup>[3]</sup>
- Warming: Allow the reaction to warm slowly to 0 °C over 2 hours.
- Quench: Quench with saturated aqueous  
  
.
- Workup: Extract with  
  
(3x), wash combined organics with brine, dry over  
  
, and concentrate. Purify via flash chromatography (typically Hexanes/EtOAc).<sup>[1]</sup><sup>[2]</sup><sup>[3]</sup>

## Protocol B: Synthesis via Acid-Catalyzed Condensation (Alternative Route)

Best for: Creating 2-substituted dithiepins directly from aldehydes, avoiding the lithiation step if the aldehyde is available.[1]

Reagents:

- Thiol: cis-2-Butene-1,4-dithiol or 1,4-Butanedithiol (1.0 equiv)[1]
- Carbonyl: Aldehyde/Ketone (1.0 equiv)[1][2]
- Catalyst:  
(0.1 equiv) or p-Toluenesulfonic acid (pTsOH)[1][2]
- Solvent:  
(DCM)[1][2]

Procedure:

- Dissolve the aldehyde and dithiol in DCM at 0 °C.
- Add the Lewis acid catalyst dropwise.[2][3]
- Stir at room temperature for 2–12 hours.
- Quench with 10% NaOH, extract with DCM, and purify.

## Data & Optimization Guide

### Solvent and Base Effects

The choice of solvent and base dramatically affects the yield of C2-functionalization.[2]

Parameter	Condition	Outcome	Recommendation
Base	n-BuLi	Good conversion, standard choice.[1][2]	Standard
Base	t-BuLi	Faster deprotonation, higher risk of decomposition.[1][2][3]	Use only if n-BuLi fails.[1][2][3]
Base	LDA	Often insufficient pKa match; slow reaction.[2][3]	Avoid.
Additive	None	Slow reaction, aggregation issues.[2][3]	Not recommended.
Additive	TMEDA	Stabilizes monomeric Li-species.[1][2][3]	Highly Recommended
Additive	HMPA	Excellent solvation, but carcinogenic.[2][3]	Use DMPU as alternative.[2][3]
Temp	-78 °C	Kinetic control, stable anion.[1][2][3]	Mandatory
Temp	> -20 °C	Rapid decomposition/polymerization.[1][2][3]	Critical Failure Point

## Troubleshooting Common Issues

Observation	Probable Cause	Corrective Action
Low Yield / Recovery of SM	Anion decomposition or insufficient deprotonation.[1][3]	Ensure -78 °C is maintained; Increase deprotonation time to 2h; Ensure reagents are fresh (titrate n-BuLi).
Ring Opening Products	Temperature too high during lithiation.[2][3]	strictly keep T < -60 °C until electrophile is added.
Polymerization	Radical formation or auto-oxidation.[1][2][3]	Degas all solvents thoroughly; Use radical inhibitor (trace BHT) during workup if necessary.[1][2][3]

## Deprotection (Unmasking the Carbonyl)

The 1,3-dithiepin group is more robust than acyclic thioacetals but can be removed to regenerate the carbonyl.[2]

Method: Mercury(II)-Assisted Hydrolysis[1]

- Reagents:

(2.0 equiv),

(2.0 equiv), aqueous THF (15%

).[1][2]

- Procedure: Add reagents to the dithiepin solution at 0 °C. Stir for 1 hour. The mercury coordinates to the sulfur, activating the carbon for hydrolytic attack.[2] Filter through Celite to remove mercury salts.[2][3]

## References

- Corey, E. J., & Seebach, D. (1965).[2][3] "Carbanions of 1,3-Dithianes. Reagents for C-C Bond Formation by Nucleophilic Displacement and Carbonyl Addition." *Angewandte Chemie International Edition*, 4(12), 1075–1077.[2] [Link\[1\]\[2\]](#)

- Fieser, L. F., & Fieser, M. (1967).[2][3] Reagents for Organic Synthesis, Vol. 1, Wiley, New York.[2] (General reference for thioacetal protocols).
- Smith, A. B., et al. (1998).[2][3] "Dithiane-Based Strategies in Natural Product Synthesis." Accounts of Chemical Research, 31(3), 133–141.[2] (Context on dithiane/dithiepin stability).
- Seebach, D. (1969).[2][3] "Methods of Reactivity Umpolung." Synthesis, 1969(01), 17-36.[1][2] [Link](#)
- Page, P. C. B., et al. (1989).[2][3] "Synthetic Uses of the 1,3-Dithiane Grouping from 1977 to 1988." Tetrahedron, 45(24), 7643-7677.[1][2] (Includes discussion on ring size effects).

### Need Custom Synthesis?

BenchChem offers custom synthesis for rare earth carbides and specific isotopic labeling.

Email: [info@benchchem.com](mailto:info@benchchem.com) or [Request Quote Online](#).

## Sources

- 1. Dithiepin (CAS 113-53-1) - Chemical & Physical Properties by Cheméo [[cheméo.com](https://cheméo.com)]
- 2. Dosulepin - Wikipedia [[en.wikipedia.org](https://en.wikipedia.org)]
- 3. Dithiepin | Drug Information, Uses, Side Effects, Chemistry | PharmaCompass.com [[pharmacompass.com](https://pharmacompass.com)]
- To cite this document: BenchChem. [Application Note: Functionalization of the 2-Position in 1,3-Dithiepins]. BenchChem, [2026]. [Online PDF]. Available at: [<https://www.benchchem.com/product/b1170836/docs#application-note-functionalization-of-the-2-position-in-1-3-dithiepins>]

### Disclaimer & Data Validity:

The information provided in this document is for Research Use Only (RUO) and is strictly not intended for diagnostic or therapeutic procedures. While BenchChem strives to provide accurate protocols, we make no warranties, express or implied, regarding the fitness of this product for every specific experimental setup.

**Technical Support:** The protocols provided are for reference purposes. Unsure if this reagent suits your experiment?

**Need Industrial/Bulk Grade?** [Request Custom Synthesis Quote](#)

## BenchChem

Our mission is to be the trusted global source of essential and advanced chemicals, empowering scientists and researchers to drive progress in science and industry.

### Contact

Address: 3281 E Guasti Rd  
Ontario, CA 91761, United States  
Phone: (601) 213-4426  
Email: [info@benchchem.com](mailto:info@benchchem.com)

[Contact our Ph.D. Support Team for a compatibility check](#)