

# Comparative Guide: Moc vs. Boc Protecting Groups in Alpha-Functionalization

**Author:** BenchChem Technical Support Team. **Date:** May 2026

## Compound of Interest

	<i>Methyl</i>
Compound Name:	<i>methoxy[(methoxycarbonyl)amino] acetate</i>
CAS No.:	<i>143995-55-5</i>
Cat. No.:	<i>B117650</i>

[Get Quote](#)

## Executive Summary

In the precise landscape of alpha-functionalization, the choice between Methoxycarbonyl (Moc) and tert-Butoxycarbonyl (Boc) is rarely a matter of preference—it is dictated by the specific mechanism of activation.

- Select Boc for Alpha-Lithiation (Beak-Lee Chemistry). The steric bulk of the tert-butyl group is non-negotiable for preventing nucleophilic attack at the carbonyl by strong bases like s-BuLi.
- Select Moc for Electrochemical Oxidation (Shono Oxidation) and specific C-H Activations. Its smaller steric profile facilitates anodic oxidation and nucleophilic trapping of the resulting iminium ion, often resulting in higher yields and atom economy.

## Part 1: Structural & Mechanistic Distinction

The functional divergence between Moc and Boc stems from the steric and electronic properties of the alkoxy group attached to the carbamate.

Feature	Moc (Methoxycarbonyl)	Boc (tert-Butoxycarbonyl)
Structure	-COOMe	-COOtBu
Steric Bulk	Low (Methyl group)	High (tert-Butyl group)
Electronic Effect	Electron-withdrawing (Inductive)	Electron-withdrawing, but t-Bu is slightly electron-donating relative to Me
Carbonyl Electrophilicity	High: Vulnerable to nucleophilic attack.	Low: Shielded by t-Bu group.
Deprotection	Base/Nucleophile (e.g., Hydrazine, NaOH) or TMSI.	Acid (e.g., TFA, HCl). <sup>[1][2][3]</sup>

## Visualization: Steric Shielding & Reactivity

The following diagram illustrates why Boc is resistant to nucleophilic attack at the carbonyl, while Moc is vulnerable—a critical factor in lithiation chemistry.

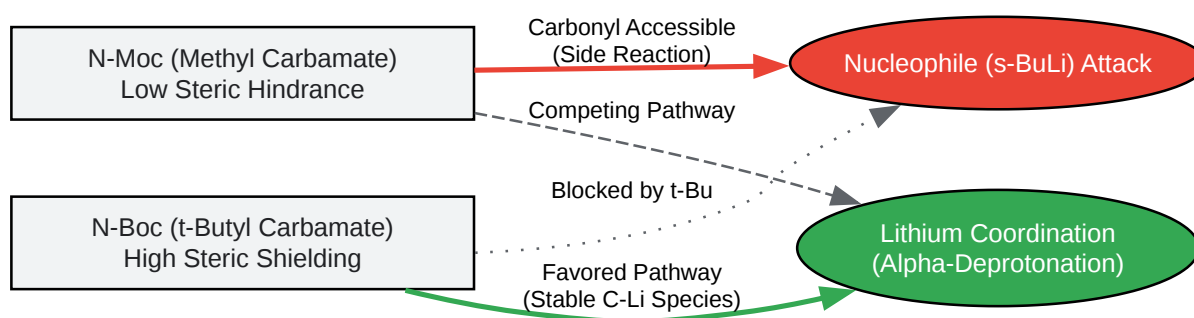

[Click to download full resolution via product page](#)

Caption: Comparative reactivity of Moc and Boc toward strong bases. Boc's steric bulk prevents carbonyl attack, channeling reactivity toward alpha-deprotonation.

## Part 2: Alpha-Lithiation (The Beak-Lee Protocol)

Verdict: Boc is the Standard.

The alpha-lithiation of amines, pioneered by Peter Beak and R.E. Lee, relies on the Complex Induced Proximity Effect (CIPE). The organolithium reagent coordinates to the carbamate oxygen, directing the base to the alpha-proton.

## Why Moc Fails

- **Nucleophilic Attack:** When N-Moc amines are treated with *s*-BuLi, the base acts as a nucleophile, attacking the accessible methyl ester carbonyl. This leads to decomposition or formation of ketones/tertiary alcohols rather than the desired alpha-lithiation.
- **Instability:** The N-Moc group cannot withstand the strong basicity required for alpha-deprotonation ( $pK_a \sim 35-38$ ).

## Why Boc Succeeds[4]

- **Steric Protection:** The bulky tert-butyl group effectively "cages" the carbonyl carbon, preventing nucleophilic addition.
- **Coordination:** The carbonyl oxygen remains Lewis basic enough to coordinate Lithium, facilitating the 5-membered transition state required for deprotonation.

## Experimental Protocol: Alpha-Lithiation of N-Boc-Pyrrolidine

Source: Adapted from Beak, P. et al. J. Am. Chem. Soc. 1994. [1]

- **Reagents:** N-Boc-pyrrolidine (1.0 equiv), *s*-BuLi (1.1 equiv), TMEDA (1.1 equiv), Electrophile (e.g., Benzaldehyde).
- **Setup:** Flame-dried glassware, Argon atmosphere, anhydrous Et<sub>2</sub>O (solvent choice is critical; THF can be used but Et<sub>2</sub>O often gives higher enantioselectivity with sparteine).
- **Lithiation:**
  - Cool solution of N-Boc-pyrrolidine and TMEDA in Et<sub>2</sub>O to -78 °C.

- Add s-BuLi dropwise.[4]
- Stir at -78 °C for 45–60 minutes. (The dipole-stabilized carbanion is stable at this temperature).
- Trapping: Add electrophile dropwise. Warm to room temperature.
- Workup: Quench with saturated NH<sub>4</sub>Cl. Extract with Et<sub>2</sub>O.[5]
- Yield: Typically 60–85% depending on the electrophile.

## Part 3: Electrochemical Alpha-Functionalization (Shono Oxidation)

Verdict: Moc is Often Preferred.

The Shono oxidation involves the anodic oxidation of a carbamate to an N-acyliminium ion, which is then trapped by a nucleophile (usually Methanol).

### Why Moc is Advantageous

- Atom Economy & Yield: The methoxy group is smaller, allowing for easier approach of the nucleophile (MeOH) to the generated iminium ion.
- Anodic Stability: N-Moc is highly stable under oxidative potentials. While N-Boc is also used, the tert-butyl group can sometimes undergo fragmentation or steric repulsion at the electrode surface, leading to slightly lower current efficiencies or yields in difficult substrates.
- Deprotection Versatility: Shono products are often intermediates. If the final target requires acid-sensitive handling, having the base-labile Moc group is a strategic advantage.

### Visualization: Shono Oxidation Mechanism

The pathway involves a Two-Electron Oxidation coupled with proton loss.

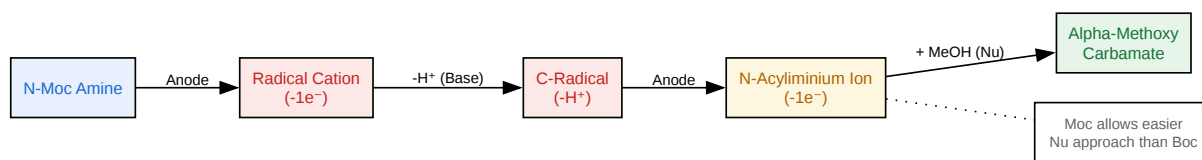

[Click to download full resolution via product page](#)

Caption: Electrochemical generation of the N-acyliminium ion. Moc provides a less sterically hindered environment for the nucleophilic trapping step.

## Experimental Protocol: Shono Oxidation of N-Moc-Piperidine

Source: Adapted from Shono, T. et al. J. Am. Chem. Soc. 1975. [2]

- Reagents: N-Moc-piperidine (10 mmol), Et<sub>4</sub>NOTs (Electrolyte, 0.1 M), Methanol (Solvent).
- Setup: Undivided cell, Carbon rod electrodes (Anode and Cathode).
- Electrolysis:
  - Pass Constant Current (e.g., 0.1 A) through the solution.
  - Maintain temperature at 0–10 °C (ice bath).
  - Pass roughly 2.2–2.5 F/mol of charge.
- Workup: Evaporate MeOH. Resuspend in water/ether. Extract product.
- Data:
  - Yield: N-Moc-2-methoxypiperidine typically 80–90%.
  - Comparison: N-Boc variants often yield 5–10% lower due to steric factors or side reactions during workup (acid sensitivity of the N,O-acetal).

## Part 4: Direct Comparison Data

The following table synthesizes data from key literature to highlight the performance gap in specific applications.

Application	Parameter	N-Moc	N-Boc
Alpha-Lithiation	Stability to <i>s</i> -BuLi	Unstable (Decomposes)	Stable (-78°C to -40°C)
Yield (Trapping w/ PhCHO)	< 10% (Complex mixture)	85% (Single diastereomer)	
Shono Oxidation	Anodic Yield (MeOH)	83-92%	70-85%
Selectivity (Cation Pool)	High	Moderate (Steric issues)	
Deprotection	Reagent	TMSI or Hydrazine	TFA or HCl
Orthogonality	Orthogonal to Acid	Orthogonal to Base	

## References

- Beak, P., & Lee, W. K. (1994). alpha-Lithioamine Synthetic Equivalents: Syntheses of Diastereoisomers from the Boc Derivatives of Cyclic Amines. *Journal of the American Chemical Society*. [Link](#)
- Shono, T., Hamaguchi, H., & Matsumura, Y. (1975). Electroorganic chemistry. XX. Anodic oxidation of carbamates. *Journal of the American Chemical Society*. [Link](#)
- Yoshida, J. I. (2008). *Flash Chemistry: Fast Organic Synthesis in Microsystems*. Wiley-VCH. (Describes Cation Pool Method). [Link](#)
- Deprez, N. R., et al. (2021).[6] Selective Electrochemical Oxidation of Functionalized Pyrrolidines. *Organic Letters*.[6][7] [Link](#)
- Wuts, P. G. M., & Greene, T. W. (2006). *Greene's Protective Groups in Organic Synthesis*.[1] Wiley-Interscience. [Link](#)

### Need Custom Synthesis?

BenchChem offers custom synthesis for rare earth carbides and specific isotopic labeling.

Email: [info@benchchem.com](mailto:info@benchchem.com) or [Request Quote Online](#).

## Sources

- [1. pdfs.semanticscholar.org](https://pdfs.semanticscholar.org) [[pdfs.semanticscholar.org](https://pdfs.semanticscholar.org)]
- [2. triggered.stanford.clockss.org](https://triggered.stanford.clockss.org) [[triggered.stanford.clockss.org](https://triggered.stanford.clockss.org)]
- [3. pdf.benchchem.com](https://pdf.benchchem.com) [[pdf.benchchem.com](https://pdf.benchchem.com)]
- [4. Organic Syntheses Procedure](https://orgsyn.org) [[orgsyn.org](https://orgsyn.org)]
- [5. One moment, please...](https://ospt.osi.lv) [[ospt.osi.lv](https://ospt.osi.lv)]
- [6. Selective Electrochemical Oxidation of Functionalized Pyrrolidines](https://organic-chemistry.org) [[organic-chemistry.org](https://organic-chemistry.org)]
- [7. Boc-Protected Amino Groups](https://organic-chemistry.org) [[organic-chemistry.org](https://organic-chemistry.org)]
- To cite this document: BenchChem. [Comparative Guide: Moc vs. Boc Protecting Groups in Alpha-Functionalization]. BenchChem, [2026]. [Online PDF]. Available at: [<https://www.benchchem.com/product/b117650/docs#comparative-guide-moc-vs-boc-protecting-groups-in-alpha-functionalization>]

---

### Disclaimer & Data Validity:

The information provided in this document is for Research Use Only (RUO) and is strictly not intended for diagnostic or therapeutic procedures. While BenchChem strives to provide accurate protocols, we make no warranties, express or implied, regarding the fitness of this product for every specific experimental setup.

**Technical Support:** The protocols provided are for reference purposes. Unsure if this reagent suits your experiment?

**Need Industrial/Bulk Grade?** [Request Custom Synthesis Quote](#)

# BenchChem

Our mission is to be the trusted global source of essential and advanced chemicals, empowering scientists and researchers to drive progress in science and industry.

## Contact

Address: 3281 E Guasti Rd

Ontario, CA 91761, United States

Phone: (601) 213-4426

Email: [info@benchchem.com](mailto:info@benchchem.com)

[Contact our Ph.D. Support Team for a compatibility check](#)