

Characterization of Poly(γ -benzyl-L-glutamate): Application Notes and Protocols

Author: BenchChem Technical Support Team. **Date:** May 2026

Compound of Interest

Compound Name: (S)-Benzyl 3-(2,5-dioxooxazolidin-4-yl)propanoate

CAS No.: 3190-71-4

Cat. No.: B117589

[Get Quote](#)

For Researchers, Scientists, and Drug Development Professionals

These application notes provide a comprehensive overview of the key techniques used to characterize poly(γ -benzyl-L-glutamate) (PBLG), a synthetic polypeptide with significant applications in drug delivery, tissue engineering, and materials science. Detailed protocols for essential experiments are included to facilitate reproducible and accurate analysis of this versatile polymer.

Molecular Weight and Purity Determination

Accurate determination of molecular weight and purity is fundamental to understanding the physicochemical properties and performance of PBLG in various applications. Techniques such as Size Exclusion Chromatography coupled with Multi-Angle Laser Light Scattering (SEC-MALLS) and Nuclear Magnetic Resonance (NMR) spectroscopy are critical for these assessments.

Size Exclusion Chromatography with Multi-Angle Laser Light Scattering (SEC-MALLS)

SEC-MALLS is a powerful technique for determining the absolute molar mass and size distribution of polymers without the need for column calibration with polymer standards.

Application Note: This method is particularly useful for assessing the number average molecular weight (M_n), weight average molecular weight (M_w), and polydispersity index (PDI) of PBLG samples.[1][2] A narrow PDI is often desirable for controlled drug release applications. PBLG can be synthesized with molecular weights ranging from approximately 7,000 to 100,000 g/mol with PDI values typically between 1.13 and 1.55.[1]

Experimental Protocol:

- **Sample Preparation:** Dissolve PBLG in a suitable solvent, such as N,N-dimethylformamide (DMF) containing 0.1 M lithium bromide (LiBr), at a concentration of 1-10 mg/mL.[1] Filter the solution through a 0.2 μm filter before injection.
- **Instrumentation:**
 - SEC system equipped with two PSS GRAM columns.[1]
 - Shodex RI-101 differential refractive index detector.[1]
 - TriStar MiniDawn light scattering detector.[1]
- **Chromatographic Conditions:**
 - Mobile Phase: DMF with 0.1 M LiBr (membrane filtered and degassed).[1][3]
 - Flow Rate: 0.5 mL/min.[1]
 - Column Temperature: 60 °C.[1]
 - Detector Temperature: 45 °C.[1]
- **Data Analysis:** Determine the refractive index increment (dn/dc) for PBLG in the mobile phase (a typical value is 0.122 mL/g).[1] Use the data from the light scattering and refractive

index detectors to calculate Mn, Mw, and PDI.

Nuclear Magnetic Resonance (NMR) Spectroscopy

^1H NMR spectroscopy is used to confirm the chemical structure of the PBLG repeating unit and can also be used to determine the degree of polymerization.[3][4][5]

Application Note: ^1H NMR provides a qualitative confirmation of the polymer structure by identifying the characteristic proton signals of the benzyl and glutamate moieties. For quantitative analysis, the integral ratios of specific peaks can be used to estimate the molecular weight.[3]

Experimental Protocol:

- Sample Preparation: Dissolve approximately 30 mg of PBLG in 0.7 mL of a deuterated solvent such as trifluoroacetic acid (CF_3COOD) or a mixture of $\text{CF}_3\text{COOD}/\text{CDCl}_3$. [1][3][4]
- Instrumentation: 400 MHz NMR spectrometer. [1][4]
- Data Acquisition: Record the ^1H NMR spectrum.
- Data Analysis: Identify the characteristic resonances: ~ 7.0 ppm (phenyl group), ~ 4.9 ppm (benzyl CH_2), and ~ 4.4 ppm (amide CH). [4]

Table 1: Summary of Molecular Weight Characterization Data for PBLG

Technique	Parameter	Typical Values	Reference
SEC-MALLS	Mn (g/mol)	6,500 - 97,000	[1]
Mw/Mn (PDI)	1.13 - 1.55	[1]	
^1H NMR	Mn (g/mol)	$\sim 5,000$ - 14,400	[3][4]

Secondary Structure Analysis

The biological activity and material properties of PBLG are highly dependent on its secondary structure, which is typically an α -helix but can also include β -sheets. [4][6]

Fourier-Transform Infrared (FTIR) Spectroscopy

FTIR is a rapid and accessible method to probe the secondary structure of polypeptides by analyzing the positions of the amide I and amide II bands.[4]

Application Note: The amide I band (C=O stretch) and amide II band (N-H bend and C-N stretch) are sensitive to the polymer's conformation. For an α -helical structure, these bands typically appear around 1650 cm^{-1} and 1546 cm^{-1} , respectively.[1] The presence of β -sheets is indicated by bands around 1630 cm^{-1} and 1530 cm^{-1} .[1]

Experimental Protocol:

- Sample Preparation: Prepare a thin film of PBLG by casting a solution onto a KBr pellet or directly analyze the solid sample using an attenuated total reflectance (ATR) accessory.
- Instrumentation: A standard FTIR spectrometer.[4]
- Data Acquisition: Collect the spectrum in the range of $4000\text{-}400\text{ cm}^{-1}$.
- Data Analysis: Analyze the positions of the amide I and amide II bands to determine the predominant secondary structure. Deconvolution of the amide I region can be used to estimate the percentage of different conformations.[4]

Circular Dichroism (CD) Spectroscopy

CD spectroscopy is a highly sensitive technique for analyzing the secondary structure of chiral molecules like polypeptides in solution.[7][8]

Application Note: The α -helical conformation of PBLG in solution gives rise to a characteristic CD spectrum with negative bands around 222 nm and 208 nm, and a positive band around 195 nm. This technique is invaluable for studying conformational changes induced by solvent, temperature, or the binding of drug molecules.

Experimental Protocol:

- Sample Preparation: Dissolve PBLG in a suitable solvent (e.g., dichloromethane) to a concentration that gives an absorbance of ~ 1.0 at 190 nm.

- Instrumentation: A CD spectrometer.
- Data Acquisition: Record the CD spectrum from 260 nm to 190 nm in a quartz cuvette with a 1 mm path length.
- Data Analysis: The resulting spectrum can be analyzed using various deconvolution algorithms to estimate the percentage of α -helix, β -sheet, and random coil structures.[7][8]

Table 2: Spectroscopic Data for PBLG Secondary Structure

Technique	Conformation	Amide I Band (cm^{-1})	Amide II Band (cm^{-1})	CD Bands (nm)	Reference
FTIR	α -helix	~1653	~1548	N/A	[1]
	β -sheet	~1630	~1530	N/A	[1]
CD	α -helix	N/A	N/A	-222, -208, +195	[8][9]

Thermal Properties

The thermal stability and transitions of PBLG are crucial for processing and for applications where it may be subjected to temperature changes.

Thermogravimetric Analysis (TGA)

TGA measures the change in mass of a sample as a function of temperature, providing information about its thermal stability and decomposition profile.

Application Note: TGA is used to determine the onset of thermal degradation of PBLG. Typically, PBLG shows good thermal stability, with decomposition starting above 280 °C.[4]

Experimental Protocol:

- Sample Preparation: Place 5-10 mg of the PBLG sample in a TGA pan.
- Instrumentation: A thermogravimetric analyzer.[4]

- Analysis Conditions:
 - Atmosphere: Nitrogen.[3][4]
 - Heating Rate: 10 °C/min.[3][4]
 - Temperature Range: 50 °C to 600 °C.[4]
- Data Analysis: Determine the onset of decomposition from the TGA curve.

Differential Scanning Calorimetry (DSC)

DSC measures the heat flow into or out of a sample as it is heated or cooled, allowing for the determination of thermal transitions such as the glass transition temperature (T_g) and melting temperature (T_m).

Application Note: DSC can reveal information about the amorphous and crystalline nature of PBLG. An endothermic peak around 100 °C may be observed, which can be attributed to an α -helical transition.[4] The glass transition temperature (T_g) is also an important parameter, with reported values around 14-26 °C for some PBLG copolymers.[4][10]

Experimental Protocol:

- Sample Preparation: Seal 5-10 mg of PBLG in an aluminum DSC pan.
- Instrumentation: A differential scanning calorimeter.[4]
- Analysis Conditions:
 - Atmosphere: Nitrogen.[3][4]
 - Heating/Cooling Rate: 20 °C/min.[4]
 - Temperature Range: -30 °C to 200 °C.[4]
- Data Analysis: Identify the T_g from the step change in the heat flow curve and the T_m from the endothermic peak.

Table 3: Thermal Properties of PBLG

Technique	Parameter	Typical Value	Reference
TGA	Decomposition Onset	> 280 °C	[4]
DSC	Glass Transition (T _g)	14 - 26 °C	[4][10]
Melting Transition (T _m)	~100 °C	[4]	

Morphological Characterization

The morphology of PBLG, whether in the form of films, nanofibers, or nanoparticles, is critical for its function in drug delivery systems and as a scaffold material.

Transmission Electron Microscopy (TEM)

TEM provides high-resolution images of the internal structure of materials, making it ideal for visualizing PBLG nanofibers and aggregates.[1][2]

Application Note: TEM can be used to observe the self-assembled structures of PBLG, such as nanofibers and spherical aggregates, in dilute solutions.[1] This is crucial for understanding the mechanisms of gel formation and for designing nanostructured materials.

Experimental Protocol:

- Sample Preparation:
 - For nanofibers, a dilute solution of PBLG (e.g., 0.05 wt% in toluene) is prepared.[1]
 - A drop of the solution is placed on a carbon-coated copper grid.
 - The solvent is allowed to evaporate at room temperature.
- Instrumentation: A transmission electron microscope.
- Imaging: The sample is imaged at an appropriate accelerating voltage.

Atomic Force Microscopy (AFM)

AFM is a powerful technique for imaging the surface topography of materials at the nanoscale.

[1][2]

Application Note: AFM can be used to visualize the three-dimensional structure of PBLG nanofibers and films, providing information on their dimensions (height and width).[1] This is complementary to TEM and provides quantitative data on the surface features.

Experimental Protocol:

- Sample Preparation:
 - A dilute solution of PBLG is deposited onto a freshly cleaved mica surface.[1]
 - The solvent is allowed to evaporate.
- Instrumentation: An atomic force microscope.
- Imaging: The surface is scanned in tapping mode to obtain topographic images.

Visualizing Characterization Workflows

The following diagrams illustrate the logical flow of characterizing PBLG, from synthesis to detailed property analysis.

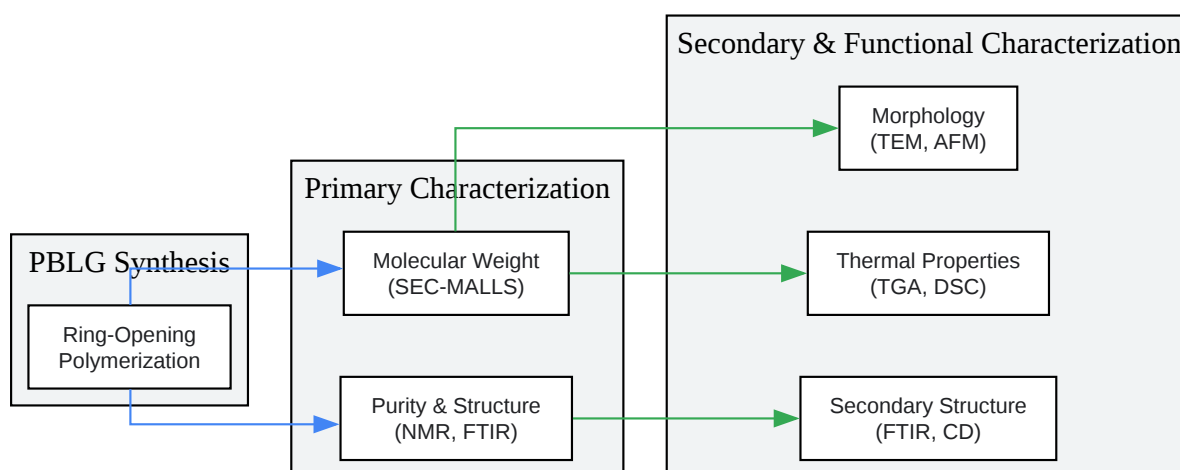

[Click to download full resolution via product page](#)

Caption: Overall workflow for PBLG characterization.

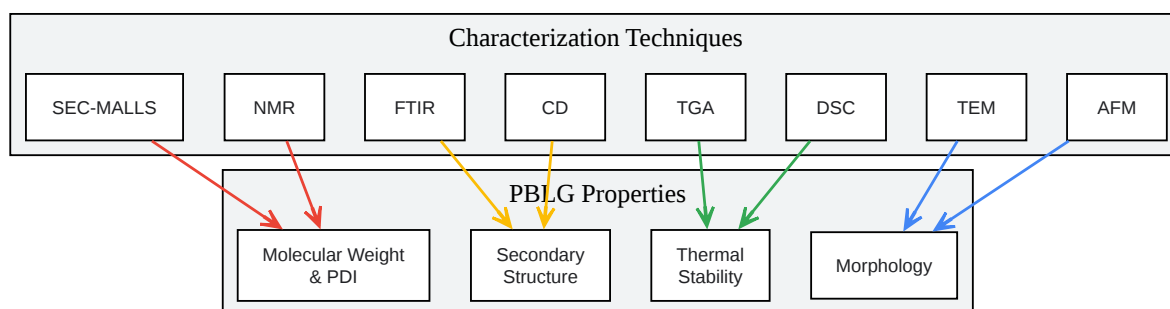

[Click to download full resolution via product page](#)

Caption: Relationship between properties and techniques.

Need Custom Synthesis?

BenchChem offers custom synthesis for rare earth carbides and specific isotopic labeling.

Email: info@benchchem.com or [Request Quote Online](#).

References

- [1. Elucidation of the structure of poly\(\$\gamma\$ -benzyl-L-glutamate\) nanofibers and gel networks in a helicogenic solvent - PMC \[pmc.ncbi.nlm.nih.gov\]](#)
- [2. researchgate.net \[researchgate.net\]](#)
- [3. bio-materials.com.cn \[bio-materials.com.cn\]](#)
- [4. mdpi.com \[mdpi.com\]](#)
- [5. rsc.org \[rsc.org\]](#)
- [6. pubs.acs.org \[pubs.acs.org\]](#)

- [7. Protein secondary structure analyses from circular dichroism spectroscopy: methods and reference databases - PubMed \[pubmed.ncbi.nlm.nih.gov\]](#)
- [8. Using circular dichroism spectra to estimate protein secondary structure - PMC \[pmc.ncbi.nlm.nih.gov\]](#)
- [9. scilit.com \[scilit.com\]](#)
- [10. Frontiers | Development of Light-Responsive Poly\(\$\gamma\$ -Benzyl-L-Glutamate\) as Photo Switches by a One-Step NCA Method \[frontiersin.org\]](#)
- To cite this document: BenchChem. [Characterization of Poly(γ -benzyl-L-glutamate): Application Notes and Protocols]. BenchChem, [2026]. [Online PDF]. Available at: [\[https://www.benchchem.com/product/b117589/docs#characterization-of-poly-benzyl-l-glutamate-application-notes-and-protocols\]](https://www.benchchem.com/product/b117589/docs#characterization-of-poly-benzyl-l-glutamate-application-notes-and-protocols)

Disclaimer & Data Validity:

The information provided in this document is for Research Use Only (RUO) and is strictly not intended for diagnostic or therapeutic procedures. While BenchChem strives to provide accurate protocols, we make no warranties, express or implied, regarding the fitness of this product for every specific experimental setup.

Technical Support: The protocols provided are for reference purposes. Unsure if this reagent suits your experiment?

Need Industrial/Bulk Grade? [Request Custom Synthesis Quote](#)

BenchChem

Our mission is to be the trusted global source of essential and advanced chemicals, empowering scientists and researchers to drive progress in science and industry.

Contact

Address: 3281 E Guasti Rd
Ontario, CA 91761, United States
Phone: (601) 213-4426
Email: info@benchchem.com

Contact our Ph.D. Support Team for a compatibility check