

An In-depth Technical Guide to d(pT)10 as a DNA Primer

Author: BenchChem Technical Support Team. **Date:** April 2026

Compound of Interest

Compound Name:	d(pT)10
CAS No.:	115760-57-1
Cat. No.:	B1168224

[Get Quote](#)

For Researchers, Scientists, and Drug Development Professionals

This guide provides a comprehensive overview of **d(pT)10**, a single-stranded DNA oligonucleotide composed of ten deoxythymidine monophosphate units. It serves as a crucial tool in a variety of molecular biology applications, primarily due to its ability to anneal to polyadenylated [poly(A)] tails of messenger RNA (mRNA) molecules.

Core Concepts and Structure

d(pT)10, also known as oligo(dT)10, is a synthetic oligonucleotide with the sequence 5'-TTTTTTTTTT-3'. Its fundamental principle of action lies in its specific hybridization to the poly(A) tail, a stretch of adenosine monophosphates found at the 3' end of most eukaryotic mRNAs. This specific binding event provides a starting point for enzymatic synthesis of a complementary DNA (cDNA) strand.

Structural Representation

The basic structure of a **d(pT)10** primer is a linear chain of ten deoxythymidine nucleotides linked by phosphodiester bonds.

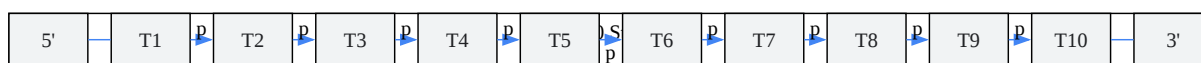

[Click to download full resolution via product page](#)

Caption: Linear structure of a **d(pT)10** oligonucleotide.

Key Applications and Experimental Protocols

The primary application of **d(pT)10** is in the reverse transcription of mRNA to synthesize cDNA. This is a foundational step for numerous downstream applications, including gene expression analysis and molecular cloning.

Reverse Transcription (RT)

Principle: **d(pT)10** primers anneal to the poly(A) tails of mRNA molecules, providing a 3'-hydroxyl group that is essential for the initiation of cDNA synthesis by a reverse transcriptase enzyme.^{[1][2]}

Experimental Workflow:

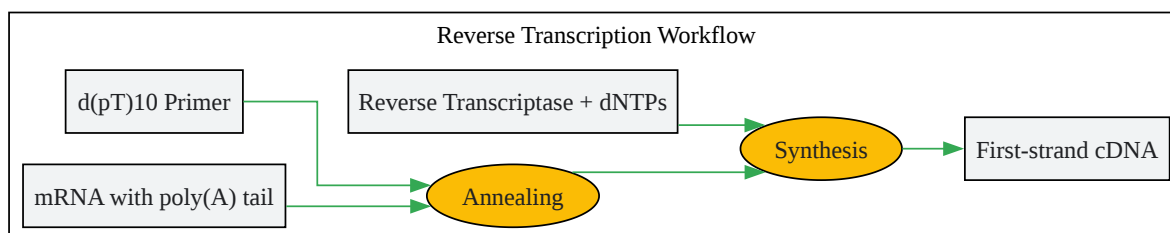

[Click to download full resolution via product page](#)

Caption: Workflow for first-strand cDNA synthesis using **d(pT)10**.

Detailed Protocol for First-Strand cDNA Synthesis:

This protocol is a generalized procedure and may require optimization based on the specific reverse transcriptase and RNA sample.

Materials:

- Total RNA or mRNA sample
- **d(pT)10** primer (10 μ M)
- Reverse Transcriptase (e.g., M-MuLV or engineered variants)
- dNTP mix (10 mM each)
- 5X Reverse Transcriptase Buffer
- RNase Inhibitor
- Nuclease-free water

Procedure:

- RNA-Primer Mix Preparation:
 - In a sterile, nuclease-free tube, combine:
 - Total RNA (1 μ g) or mRNA (100 ng)
 - **d(pT)10** primer (1 μ l)
 - dNTP mix (1 μ l)
 - Nuclease-free water to a final volume of 13 μ l.
- Denaturation and Annealing:
 - Gently mix the components.
 - Incubate at 65°C for 5 minutes to denature RNA secondary structures.

- Immediately place on ice for at least 1 minute to allow for primer annealing.
- Reverse Transcription Reaction Setup:
 - To the RNA-primer mix, add:
 - 5X Reverse Transcriptase Buffer (4 μ l)
 - RNase Inhibitor (1 μ l)
 - Reverse Transcriptase (1 μ l)
- Incubation:
 - Incubate the reaction at 42°C for 50-60 minutes. For reverse transcriptases with higher thermostability, this temperature can be increased to 50-55°C to overcome complex RNA secondary structures.[\[1\]](#)
- Enzyme Inactivation:
 - Terminate the reaction by heating at 70-85°C for 5-15 minutes.[\[1\]](#)
- Storage:
 - The resulting first-strand cDNA can be stored at -20°C for immediate use or at -80°C for long-term storage.

Component	Volume	Final Concentration
Total RNA	X μ l	1 μ g
d(pT)10 Primer (10 μ M)	1 μ l	0.5 μ M
dNTP Mix (10 mM)	1 μ l	0.5 mM
5X RT Buffer	4 μ l	1X
RNase Inhibitor	1 μ l	20 units
Reverse Transcriptase	1 μ l	200 units
Nuclease-free Water	to 20 μ l	-

Table 1: Typical Reaction Setup for First-Strand cDNA Synthesis.

Quantitative PCR (qPCR)

Principle: The cDNA synthesized using **d(pT)10** primers serves as a template for qPCR, allowing for the quantification of specific mRNA transcripts. This is a common method for gene expression analysis.

Logical Relationship:

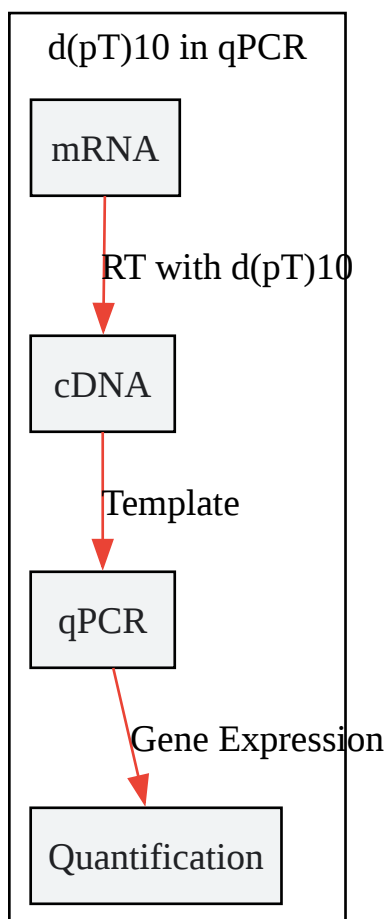

[Click to download full resolution via product page](#)

Caption: Role of **d(pT)10**-primed cDNA in qPCR.

Digital PCR (dPCR)

Principle: dPCR provides absolute quantification of nucleic acids by partitioning the sample into thousands of individual reactions.[3][4] The cDNA generated with **d(pT)10** can be used as the input for dPCR to obtain precise measurements of gene expression levels without the need for a standard curve.[3]

Experimental Considerations for dPCR with **d(pT)10**-primed cDNA:

Parameter	Recommendation	Rationale
cDNA Input	Dilute cDNA sample	To ensure that not all partitions contain the target, allowing for accurate Poisson statistical analysis.
Primer/Probe Design	Target a region within the transcript	The d(pT)10 primer initiates synthesis at the 3' end. Ensure the qPCR/dPCR assay targets a region upstream of the poly(A) tail.
Data Analysis	Poisson statistics	The number of positive partitions is used to calculate the absolute number of target molecules.

Table 2: Key Considerations for dPCR using **d(pT)10**-derived cDNA.

Comparison with Other Priming Strategies

The choice of primer for reverse transcription is critical and depends on the specific research goals.

Primer Type	Sequence	Priming Site	Advantages	Disadvantages
d(pT)10 (Oligo(dT))	TTTTTTTTTT	Poly(A) tail of mRNA	Enriches for full-length mRNA transcripts.	Does not prime non-polyadenylated RNAs (e.g., bacterial mRNA, some non-coding RNAs). May have a 3' bias for long transcripts.
Random Hexamers	NNNNNN	Randomly throughout the RNA	Primes all types of RNA, including degraded RNA and non-polyadenylated RNA.[1]	Can result in fragmented cDNA and an overrepresentation of ribosomal RNA.
Gene-Specific Primers	Sequence-specific	A specific target RNA sequence	Provides the highest specificity for a single target RNA.[1]	Requires prior knowledge of the target sequence. A different primer is needed for each target.

Table 3: Comparison of Common Reverse Transcription Priming Strategies.

Conclusion

d(pT)10 is an indispensable tool for researchers in molecular biology, genomics, and drug development. Its ability to specifically prime the reverse transcription of polyadenylated mRNA makes it a cornerstone of techniques for gene expression analysis and cDNA library construction. Understanding the principles of its application and the nuances of experimental design is crucial for obtaining reliable and reproducible results. This guide provides the foundational knowledge and practical protocols to effectively utilize **d(pT)10** in a research setting.

Need Custom Synthesis?

BenchChem offers custom synthesis for rare earth carbides and specific isotopic labeling.

Email: info@benchchem.com or [Request Quote Online](#).

References

- [1. Reverse Transcription Reaction Setup | Thermo Fisher Scientific - HK \[thermofisher.com\]](#)
- [2. Reverse Transcription \[sigmaaldrich.com\]](#)
- [3. Digital PCR provides sensitive and absolute calibration for high throughput sequencing - PMC \[pmc.ncbi.nlm.nih.gov\]](#)
- [4. Digital PCR \[sigmaaldrich.com\]](#)
- To cite this document: BenchChem. [An In-depth Technical Guide to d(pT)10 as a DNA Primer]. BenchChem, [2026]. [Online PDF]. Available at: [\[https://www.benchchem.com/product/b1168224/docs#an-in-depth-technical-guide-to-d-pt-10-as-a-dna-primer\]](https://www.benchchem.com/product/b1168224/docs#an-in-depth-technical-guide-to-d-pt-10-as-a-dna-primer)

Disclaimer & Data Validity:

The information provided in this document is for Research Use Only (RUO) and is strictly not intended for diagnostic or therapeutic procedures. While BenchChem strives to provide accurate protocols, we make no warranties, express or implied, regarding the fitness of this product for every specific experimental setup.

Technical Support: The protocols provided are for reference purposes. Unsure if this reagent suits your experiment?

Need Industrial/Bulk Grade? [Request Custom Synthesis Quote](#)

BenchChem

Our mission is to be the trusted global source of essential and advanced chemicals, empowering scientists and researchers to drive progress in science and industry.

Contact

Address: 3281 E Guasti Rd

Ontario, CA 91761, United States

Phone: (601) 213-4426

Email: info@benchchem.com

[Contact our Ph.D. Support Team for a compatibility check](#)