

Technical Support Center: Strategies to Minimize Red Blood Cell Storage Lesions

Author: BenchChem Technical Support Team. **Date:** April 2026

Compound of Interest

Compound Name: hemoce
CAS No.: 110120-01-9
Cat. No.: B1167965

[Get Quote](#)

This technical support center provides researchers, scientists, and drug development professionals with troubleshooting guides, frequently asked questions (FAQs), and detailed protocols to address common issues encountered during red blood cell (RBC) storage and experimentation.

Frequently Asked Questions (FAQs)

Q1: What is the "red blood cell storage lesion"?

A1: The red blood cell storage lesion refers to the collective series of biochemical and biomechanical changes that occur when RBCs are stored.^{[1][2]} These changes impair the function and viability of the cells.^[1] Key changes include the depletion of adenosine triphosphate (ATP) and 2,3-diphosphoglycerate (2,3-DPG), oxidative damage to proteins and lipids, potassium leakage, and alterations in cell shape and membrane flexibility.^{[3][4][5]} Ultimately, these lesions can reduce the efficacy of transfusions and the quality of cells for research purposes.^[1]

Q2: What are the primary causes of the storage lesion?

A2: The primary causes can be broadly categorized into metabolic impairments and oxidative damage.[4][5]

- **Metabolic Impairment:** Removed from the body's circulation, RBCs are stored in an artificial, acidic solution with a limited volume and nutrient supply at low temperatures (1-6°C).[4][6] This environment slows enzymatic activity, leading to an accumulation of metabolic byproducts like lactate, a drop in pH, and the depletion of crucial energy and oxygen-delivery molecules like ATP and 2,3-DPG.[3][5][6]
- **Oxidative Damage:** Stored RBCs are susceptible to oxidative stress from reactive oxygen species (ROS).[5] This leads to the oxidation of hemoglobin, damage to membrane proteins and lipids, and a reduction in the cells' antioxidant capacity, further degrading cell function.[6]

Q3: What are the main strategies to minimize RBC storage lesions?

A3: The main strategies focus on improving the storage environment and restoring cellular components post-storage. These include:

- **Advanced Additive Solutions (AS):** These are nutrient-rich solutions designed to better preserve RBCs.[7] Newer formulations are often alkaline and chloride-free, which helps maintain a higher intracellular pH, thereby preserving ATP and 2,3-DPG levels for longer periods.[8][9]
- **Post-Storage Rejuvenation:** This process involves incubating stored RBCs with a solution containing components like pyruvate, inosine, phosphate, and adenine.[10][11] This treatment is designed to replenish depleted levels of ATP and 2,3-DPG, which can restore the cells' oxygen-releasing capacity and improve other metabolic functions.[12][13]
- **Interim Washing:** Washing packed RBCs during the storage period can remove accumulated microvesicles and cell-free hemoglobin, which are components of the storage lesion.[14] This has been shown to decrease osmotic fragility and reduce markers of cell damage.[14]

Q4: How does a decrease in 2,3-DPG affect RBC function?

A4: 2,3-diphosphoglycerate (2,3-DPG) is a crucial molecule that regulates hemoglobin's affinity for oxygen. Depletion of 2,3-DPG during storage increases hemoglobin's oxygen affinity.[12] This means the RBCs are less efficient at releasing oxygen to the tissues after transfusion,

potentially compromising the primary goal of the therapy.[12] Rejuvenation treatments are effective at restoring 2,3-DPG levels.[10][12]

Q5: Can the storage lesion be fully reversed?

A5: Not entirely. While some aspects of the storage lesion, particularly metabolic changes like depleted ATP and 2,3-DPG, can be partially or significantly reversed by rejuvenation or upon transfusion, other changes are irreversible.[15][16] For example, damage to the cytoskeleton, membrane protein degradation, and the loss of membrane via microvesiculation are generally not reversible.[15][16] The extent of reversal often depends on the duration of storage and the severity of the accumulated damage.[15]

Troubleshooting Guide

Problem / Observation	Potential Cause(s)	Recommended Solution(s)
Higher-than-expected hemolysis (>0.8%) early in storage (Week 1-2).	<ol style="list-style-type: none"> Improper processing or handling (e.g., excessive centrifugation speed, temperature fluctuations). Suboptimal additive solution or incorrect RBC-to-AS ratio. Donor-specific variability (RBCs from some donors are more fragile).[4] 	<ol style="list-style-type: none"> Review and standardize your cell processing protocol. Ensure storage refrigerators maintain a stable temperature between 1-6°C.[17] Use a calibrated thermometer for monitoring.[17] Verify the composition and pH of your additive solution. Ensure the correct volume is used for the packed RBC volume. If possible, screen units from multiple donors. Note any donor-dependent differences in your experimental records.
Rapid decline in ATP and/or 2,3-DPG levels.	<ol style="list-style-type: none"> Acidic storage environment (low pH inhibits glycolysis).[4] Inadequate glucose or adenine in the additive solution. Oxidative stress damaging glycolytic enzymes.[4] 	<ol style="list-style-type: none"> Use a buffered, alkaline additive solution (e.g., AS-7, PAG3M) to maintain a higher intracellular pH.[8] Ensure your additive solution is properly formulated with sufficient glucose and adenine to support metabolism.[7] Consider anaerobic or hypoxic storage conditions to reduce oxidative damage.[4]
Inconsistent results between experimental batches.	<ol style="list-style-type: none"> Variability in donor blood. Inconsistent overnight hold time or temperature before processing. Differences in processing methods (e.g., buffy coat removal vs. whole blood filtration).[4] 	<ol style="list-style-type: none"> For mechanistic studies, use a "pool-and-split" design where blood from multiple donors is pooled before being split into control and experimental groups.[8] Standardize the pre-processing hold conditions (e.g., 18-24 hours at room temperature). Use a

		<p>consistent and clearly documented method for preparing your packed RBC units.</p>
<p>Rejuvenation treatment fails to restore ATP/2,3-DPG levels adequately.</p>	<p>1. Rejuvenation solution is expired or improperly prepared.2. Incubation time or temperature is incorrect.3. The stored RBCs are too old or severely damaged for effective rejuvenation.[15]</p>	<p>1. Prepare rejuvenation solution fresh or verify the quality of commercial solutions. A typical solution contains pyruvate, inosine, phosphate, and adenine.[10]2. Ensure incubation is performed at 37°C for 1 hour. [10]3. Perform rejuvenation on units stored for shorter durations to establish a baseline. The effectiveness of rejuvenation decreases as storage time increases.[15]</p>
<p>Observed morphological changes (e.g., echinocytes, spherocytes) appear earlier than expected.</p>	<p>1. ATP depletion, leading to cytoskeleton disorganization. [4]2. Oxidative damage to the cell membrane.[6]3. Suboptimal composition of additive solution (e.g., lack of membrane stabilizers like mannitol).[7]</p>	<p>1. Implement strategies to maintain higher ATP levels (see above).2. Incorporate antioxidants into the additive solution or consider hypoxic storage.[4]3. Use an additive solution containing mannitol, such as SAGM or PAGGSM, which helps reduce osmotic lysis and may act as an antioxidant.[7][9]</p>

Data Presentation: Additive Solution Comparison

The choice of additive solution is critical for mitigating storage lesions. Newer generation solutions are designed to better control pH and support RBC metabolism.

Table 1: Composition of Common Red Blood Cell Additive Solutions

Component	SAGM	PAGGSM	PAG3M	E-Sol 5	AS-7
Sodium Chloride (mmol/L)	150	113	-	-	-
Adenine (mmol/L)	1.25	1.25	2.5	2.0	2.0
Glucose (mmol/L)	50.5	111	111	111	55.5
Mannitol (mmol/L)	29	29	42	-	-
Phosphate (mmol/L)	-	12.5	25	25	12.5
Guanosine (mmol/L)	-	0.7	0.7	-	-
Sodium Gluconate (mmol/L)	-	-	113	113	87.5
Sodium Bicarbonate (mmol/L)	-	-	-	-	12.5
Reference(s)	[8]	[8]	[8]	[8]	[8][18]

Note: This table summarizes key components; formulations may have minor variations.

Table 2: Impact of Additive Solutions on Key RBC Quality Metrics During Storage

Parameter	SAGM & PAGGSM	PAG3M, E-Sol 5, AS-7
Intracellular ATP Levels	Gradual decline over storage.	Significantly higher levels maintained throughout storage.[8]
2,3-DPG Levels	Rapidly depleted within the first two weeks of storage.[8]	Depletion is inhibited or delayed; PAG3M can even increase levels initially.[8]
Lactate Production	Standard rate of production.	Significantly higher lactate production, indicating more active glycolysis.[8]
Hemolysis	Comparable to other solutions until day 35, after which it increases more significantly.[8]	Lower hemolysis rates, especially during prolonged storage beyond 35 days.[8]
Cell Morphology	Progressive degradation of cell shape.	Better maintenance of normal morphological properties over time.[8]

Key Experimental Protocols

Protocol 1: Evaluation of Hemolysis in Stored RBCs

This protocol measures the percentage of free hemoglobin in the supernatant, a key indicator of RBC damage.

Materials:

- Packed Red Blood Cell (pRBC) unit in a storage bag.
- 1.5 mL microcentrifuge tubes.
- Phosphate-buffered saline (PBS).
- Spectrophotometer.
- Drabkin's reagent (or similar hemoglobin quantification kit).

Methodology:

- Gently mix the pRBC storage bag for 5 minutes to ensure a homogenous sample.[19]
- Aseptically remove a 1 mL aliquot of the pRBC suspension.
- Transfer the sample to a 1.5 mL microcentrifuge tube.
- Centrifuge at 1,500 x g for 10 minutes to pellet the intact red cells.
- Carefully collect the supernatant without disturbing the cell pellet. This contains the cell-free hemoglobin.
- To measure total hemoglobin, lyse a separate 20 µL aliquot of the original pRBC suspension in 980 µL of deionized water.
- Measure the hemoglobin concentration in both the supernatant and the total lysate sample using a spectrophotometer and Drabkin's reagent, following the manufacturer's instructions.
- Calculation:
 - $\text{Percent Hemolysis} = (\text{Hemoglobin in Supernatant} / \text{Total Hemoglobin}) \times 100$
- The acceptable upper limit for hemolysis at the end of storage is typically 0.8% in the US and 1% in Europe.[20]

Protocol 2: Post-Storage Rejuvenation of RBCs

This protocol describes the process of metabolically rejuvenating stored erythrocytes to restore ATP and 2,3-DPG levels.

Materials:

- Stored pRBC unit.
- Rejuvenation solution (e.g., Rejuvesol™ or a lab-prepared solution containing sodium pyruvate, inosine, adenine, and sodium phosphate).[10]

- Sterile saline wash solution.
- Water bath at 37°C.
- Sterile centrifuge tubes.
- Refrigerated centrifuge.

Methodology:

- Isolate erythrocytes from the stored blood unit by centrifugation and removal of the supernatant.
- Prepare the rejuvenation solution according to the manufacturer's protocol or published formulations (e.g., 100 mM sodium pyruvate, 99.9 mM inosine, 5 mM adenine, and phosphate buffers).[10]
- Add the rejuvenation solution to the packed red cells at a specified ratio (e.g., 50 mL of solution per unit of pRBCs).
- Incubate the mixture in a sterile container in a 37°C water bath for 1 hour, with gentle agitation.[10]
- After incubation, wash the rejuvenated RBCs to remove the components of the rejuvenation solution. This is typically done by adding sterile saline, centrifuging the cells, and decanting the supernatant. Repeat this wash step at least twice.[10]
- After the final wash, resuspend the RBCs in an appropriate storage or transfusion solution (e.g., saline-adenine-glucose).
- The rejuvenated cells are now ready for quality assessment (e.g., ATP/2,3-DPG measurement) or experimental use. Rejuvenation has been shown to restore ATP to near-normal levels and significantly decrease markers of cell damage like phosphatidylserine (PS) exposure.[13]

Visualizations: Pathways and Workflows

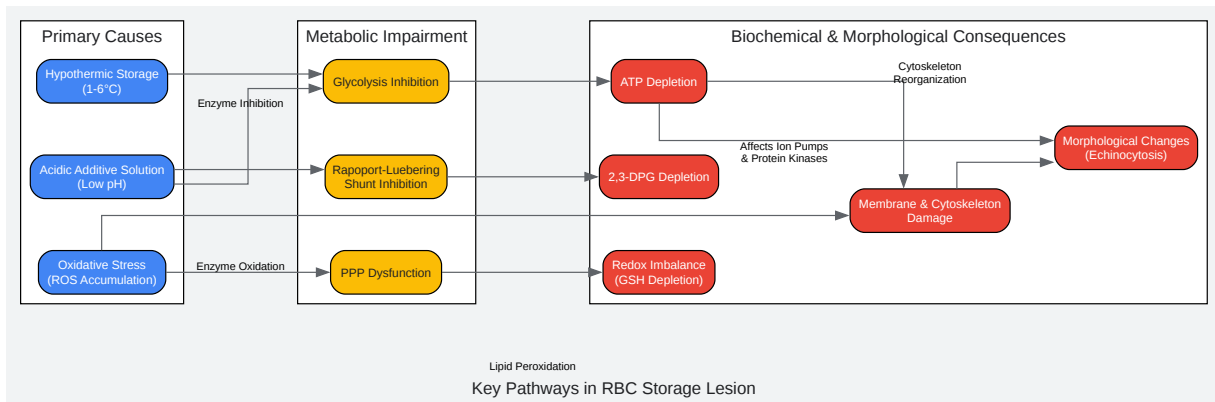

[Click to download full resolution via product page](#)

Caption: Key pathways involved in the RBC storage lesion.

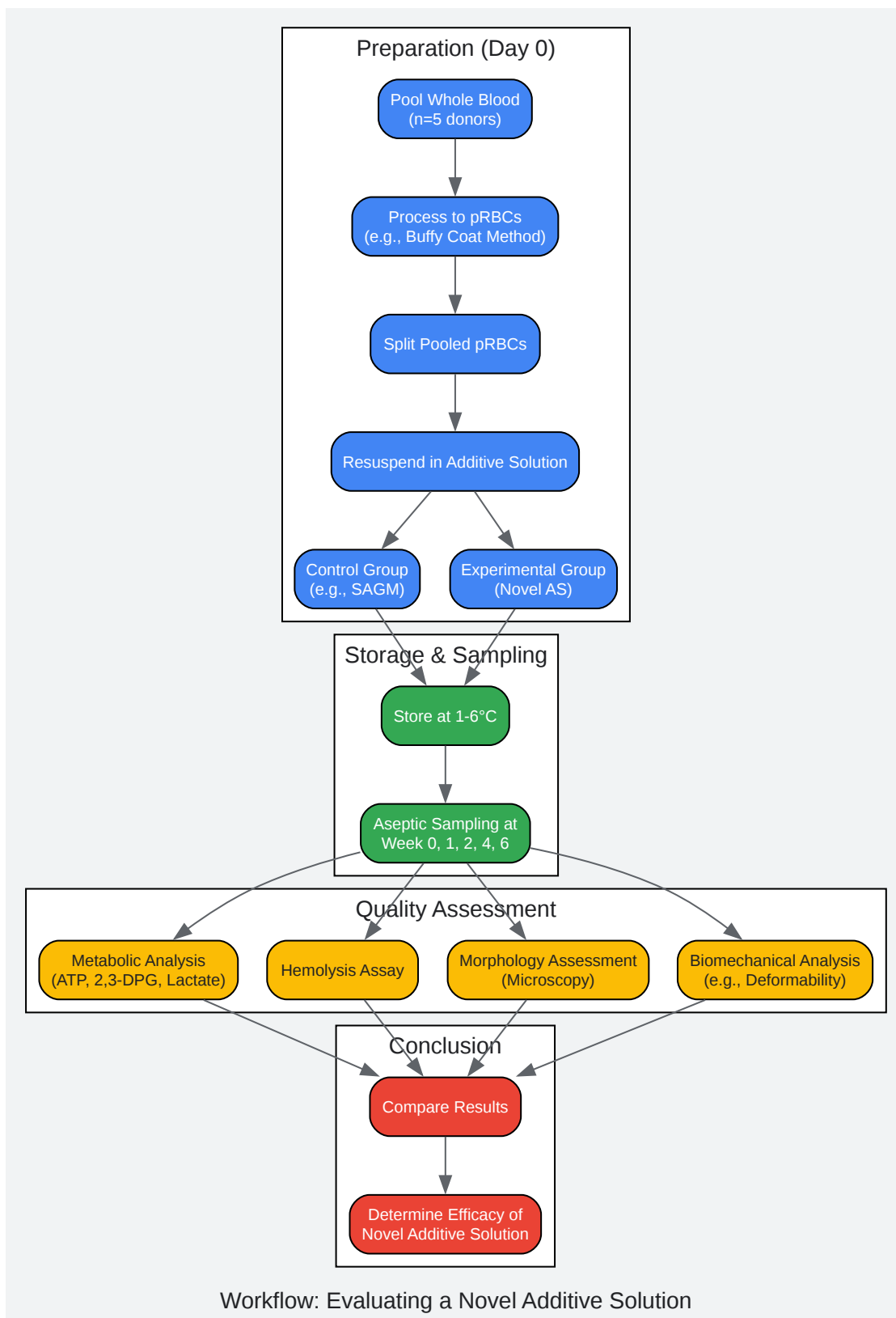

[Click to download full resolution via product page](#)

Caption: Experimental workflow for evaluating a new additive solution.

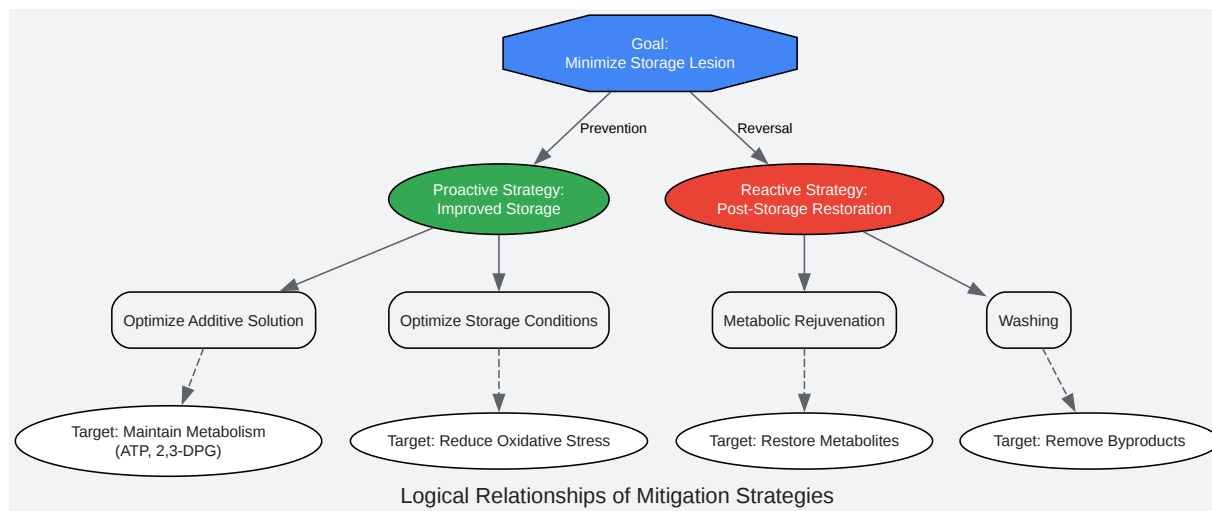

[Click to download full resolution via product page](#)

Caption: Logical relationships between different mitigation strategies.

Need Custom Synthesis?

BenchChem offers custom synthesis for rare earth carbides and specific isotopic labeling.

Email: info@benchchem.com or [Request Quote Online](#).

References

- 1. [slideshare.net](https://www.slideshare.net) [slideshare.net]
- 2. [ashpublications.org](https://www.ashpublications.org) [ashpublications.org]
- 3. Biochemical changes in stored donor units: implications on the efficacy of blood transfusion - PMC [pmc.ncbi.nlm.nih.gov]

- 4. Red blood cell storage lesion: causes and potential clinical consequences - PMC [[pmc.ncbi.nlm.nih.gov](https://pubmed.ncbi.nlm.nih.gov)]
- 5. Red Blood Cell (RBC) Storage Lesions and Their Clinical Consequences [[vitasang.com](https://www.vitasang.com)]
- 6. [wjgnet.com](https://www.wjgnet.com) [[wjgnet.com](https://www.wjgnet.com)]
- 7. [tandfonline.com](https://www.tandfonline.com) [[tandfonline.com](https://www.tandfonline.com)]
- 8. Prevention of red cell storage lesion: a comparison of five different additive solutions - PMC [[pmc.ncbi.nlm.nih.gov](https://pubmed.ncbi.nlm.nih.gov)]
- 9. Time to revisit red blood cell additive solutions and storage conditions: a role for “omics” analyses - PMC [[pmc.ncbi.nlm.nih.gov](https://pubmed.ncbi.nlm.nih.gov)]
- 10. Effects of rejuvenation on young and old erythrocytes of banked blood towards the end of storage period - PMC [[pmc.ncbi.nlm.nih.gov](https://pubmed.ncbi.nlm.nih.gov)]
- 11. Therapeutic effectiveness and safety of outdated human red blood cells rejuvenated to improve oxygen transport function, frozen for about 1.5 years at 80 C, washed, and stored at 4 C for 24 hours prior to rapid infusion - PubMed [pubmed.ncbi.nlm.nih.gov]
- 12. [ashpublications.org](https://www.ashpublications.org) [[ashpublications.org](https://www.ashpublications.org)]
- 13. Metabolic rejuvenation upgrades circulatory functions of red blood cells stored under blood bank conditions - PubMed [pubmed.ncbi.nlm.nih.gov]
- 14. Washing packed red blood cells decreases red blood cell storage lesion formation - PubMed [pubmed.ncbi.nlm.nih.gov]
- 15. [karger.com](https://www.karger.com) [[karger.com](https://www.karger.com)]
- 16. Frontiers | Is It Possible to Reverse the Storage-Induced Lesion of Red Blood Cells? [[frontiersin.org](https://www.frontiersin.org)]
- 17. [medicblood.org](https://www.medicblood.org) [[medicblood.org](https://www.medicblood.org)]
- 18. Red blood cell storage in additive solution-7 preserves energy and redox metabolism: a metabolomics approach - PubMed [pubmed.ncbi.nlm.nih.gov]
- 19. Label-free testing strategy to evaluate packed red blood cell quality before transfusion to leukemia patients - PMC [[pmc.ncbi.nlm.nih.gov](https://pubmed.ncbi.nlm.nih.gov)]
- 20. [lifesciencehistory.com](https://www.lifesciencehistory.com) [[lifesciencehistory.com](https://www.lifesciencehistory.com)]
- To cite this document: BenchChem. [Technical Support Center: Strategies to Minimize Red Blood Cell Storage Lesions]. BenchChem, [2026]. [Online PDF]. Available at: [<https://www.benchchem.com/product/b1167965/docs#technical-support-center-strategies-to-minimize-red-blood-cell-storage-lesions>]

Disclaimer & Data Validity:

The information provided in this document is for Research Use Only (RUO) and is strictly not intended for diagnostic or therapeutic procedures. While BenchChem strives to provide accurate protocols, we make no warranties, express or implied, regarding the fitness of this product for every specific experimental setup.

Technical Support: The protocols provided are for reference purposes. Unsure if this reagent suits your experiment?

Need Industrial/Bulk Grade? [Request Custom Synthesis Quote](#)

BenchChem

Our mission is to be the trusted global source of essential and advanced chemicals, empowering scientists and researchers to drive progress in science and industry.

Contact

Address: 3281 E Guasti Rd
Ontario, CA 91761, United States
Phone: (601) 213-4426
Email: info@benchchem.com

[Contact our Ph.D. Support Team for a compatibility check](#)