

Technical Support Center: Cross-matching for Multi-transfused Patients

Author: BenchChem Technical Support Team. **Date:** April 2026

Compound of Interest

Compound Name: hemoce
CAS No.: 110120-01-9
Cat. No.: B1167965

[Get Quote](#)

This technical support center provides troubleshooting guides and frequently asked questions (FAQs) to assist researchers, scientists, and drug development professionals in addressing the challenges associated with cross-matching for multi-transfused patients.

Troubleshooting Guides

This section offers step-by-step guidance for resolving common issues encountered during cross-matching procedures for patients with a history of multiple transfusions.

Issue 1: Incompatible Cross-match in a Multi-transfused Patient

Question: I am getting an incompatible cross-match for a patient who has received multiple transfusions. What are the initial steps to resolve this?

Answer:

An incompatible cross-match in a multi-transfused patient is often due to the presence of alloantibodies, which are antibodies developed against foreign red blood cell (RBC) antigens

from previous transfusions. The presence of autoantibodies can also lead to panreactive results, complicating the picture. Here is a systematic approach to troubleshooting:

Initial Steps:

- Repeat the Cross-match: To rule out technical or clerical errors, repeat the cross-match with the same donor unit and also with two additional group-specific donor units.^[1] If the incompatibility persists, proceed with further investigation.
- Perform a Direct Antiglobulin Test (DAT): A DAT will determine if the patient's RBCs are coated with antibodies in vivo.^[2] A positive DAT may indicate the presence of autoantibodies or alloantibodies attached to transfused red cells.
- Conduct an Antibody Screen: The patient's plasma or serum should be screened for unexpected antibodies using a panel of commercially available O-type RBCs with known antigen profiles.^{[3][4]}
- Perform an Autocontrol: Testing the patient's serum against their own red cells (autocontrol) helps to differentiate between alloantibodies and autoantibodies. A negative autocontrol with a positive antibody screen suggests the presence of alloantibodies.^[5] A positive autocontrol suggests the presence of autoantibodies.

Logical Workflow for an Incompatible Cross-match:

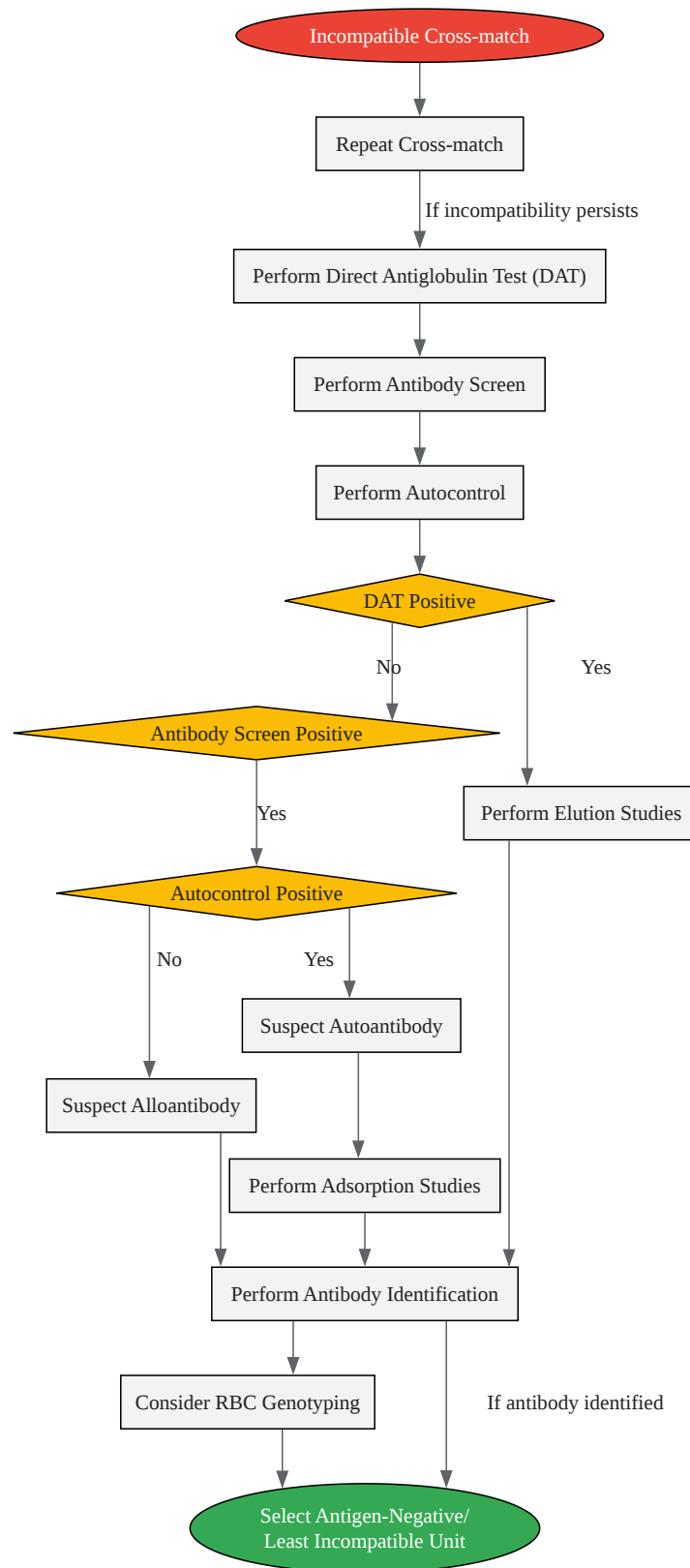

[Click to download full resolution via product page](#)

Figure 1: Troubleshooting workflow for an incompatible cross-match.

Issue 2: Panreactive Antibody Screen

Question: The antibody screen is positive with all panel cells, and the autocontrol is also positive. What is the next step?

Answer:

A panreactive antibody screen with a positive autocontrol is highly suggestive of the presence of autoantibodies, which may or may not be masking clinically significant alloantibodies.

Troubleshooting Steps:

- Perform Adsorption Studies: Adsorption techniques are used to remove the autoantibodies from the patient's serum, allowing for the detection of any underlying alloantibodies.[6]
 - Autoadsorption: The patient's own red cells are used to adsorb the autoantibodies. This is the preferred method but cannot be used if the patient has been recently transfused (within the last 3 months).
 - Allogeneic Adsorption: If autoadsorption is not feasible, red cells from a donor with a known phenotype can be used to adsorb the autoantibodies.
- Test the Adsorbed Serum: The adsorbed serum is then re-tested against an antibody identification panel to identify any alloantibodies that may have been masked by the autoantibodies.
- Perform Elution Studies: An elution is performed on the patient's DAT-positive red cells to remove the coating antibodies.[7] The eluate is then tested against an antibody panel to identify the specificity of the antibody coating the red cells.

Frequently Asked Questions (FAQs)

Q1: What is alloimmunization and why is it a concern in multi-transfused patients?

A1: Alloimmunization is an immune response to foreign antigens on transfused red blood cells. [8] In multi-transfused patients, repeated exposure to different donor RBCs increases the risk of developing antibodies against various blood group antigens. These alloantibodies can lead to

delayed hemolytic transfusion reactions, difficulties in finding compatible blood for future transfusions, and, in rare cases, acute hemolytic reactions.[9][10]

Q2: How common is alloimmunization in multi-transfused patients?

A2: The rate of alloimmunization varies depending on the patient population, the number of units transfused, and the degree of antigenic differences between donors and recipients. Studies have reported alloimmunization rates ranging from 5% to over 30% in chronically transfused patients, such as those with thalassemia or sickle cell disease.[11][12]

Q3: What are the most common alloantibodies found in multi-transfused patients?

A3: The most frequently identified alloantibodies are directed against antigens in the Rh (e.g., anti-E, anti-c) and Kell (e.g., anti-K) blood group systems.[2][11][13][14] Antibodies to antigens in the Duffy, Kidd, and MNS systems are also commonly observed.

Q4: What is the role of molecular genotyping in cross-matching for multi-transfused patients?

A4: Molecular genotyping is a powerful tool that can predict a patient's red blood cell antigen profile from their DNA.[15] This is particularly useful for multi-transfused patients where recent transfusions can lead to a mixed population of red cells, making traditional serological phenotyping unreliable.[16][17] Genotyping can help in identifying the patient's true antigen profile, allowing for the provision of more accurately matched blood and reducing the risk of further alloimmunization.[18][19]

Q5: What should I do if a patient with a known alloantibody requires an urgent transfusion and antigen-negative blood is not immediately available?

A5: In a life-threatening emergency, if antigen-negative blood is unavailable, the decision to transfuse "least incompatible" blood may be made in consultation with the transfusion medicine physician.[20] This involves selecting donor units that show the weakest reaction with the patient's plasma. The transfusion should be administered slowly with close monitoring of the patient for any signs of a transfusion reaction.

Data Presentation

Table 1: Prevalence of Alloimmunization in Multi-transfused Patients

Patient Population	Number of Patients Studied	Alloimmunization Rate (%)	Most Common Alloantibodies	Reference(s)
Thalassemia	96	5.21	Anti-K, Rh system	
Thalassemia	100	6.0	-	[21]
Thalassemia & Solid Malignancies	100	7.0	Anti-K, Anti-E, Anti-c, Anti-M	[2]
Oncology	162	6.0	Anti-E, Anti-K, Anti-C, Anti-D	
Various (including Thalassemia)	14,387	0.69 (incompatible cross-match rate)	Rh system (Anti-E, Anti-c)	[13][22]
Thalassemia	Not Specified	33.9	Anti-E, Anti-Mia	[12]

Experimental Protocols

Protocol 1: Indirect Antiglobulin Test (IAT) for Antibody Screening

Objective: To detect clinically significant "unexpected" antibodies in the patient's serum or plasma.

Materials:

- Patient's serum or plasma
- Commercially prepared screening cells (a set of 2 or 3 vials of group O red cells with known antigen profiles)[3][23]
- Anti-Human Globulin (AHG) reagent

- Low-Ionic-Strength Saline (LISS)
- Test tubes, centrifuge, incubator (37°C)

Procedure:

- Label test tubes appropriately for each screening cell.
- Add 2 drops of patient's serum or plasma to each tube.
- Add 1 drop of the corresponding screening cells to each tube.
- Add 2 drops of LISS to enhance antibody uptake.
- Mix gently and incubate at 37°C for 15-30 minutes.[\[24\]](#)
- After incubation, wash the cells three to four times with saline to remove unbound antibodies.
[\[24\]](#)
- Decant the supernatant completely after the final wash.
- Add 2 drops of AHG reagent to the dry cell button in each tube.
- Mix gently and centrifuge according to the manufacturer's instructions (e.g., 1500 rpm for 1 minute).[\[18\]](#)
- Gently resuspend the cell button and examine for agglutination macroscopically and microscopically.
- Grade and record the reactions. Agglutination or hemolysis indicates a positive result.

Protocol 2: Acid Elution

Objective: To remove antibodies that are coating red blood cells for identification.

Materials:

- Patient's washed, packed red blood cells (DAT positive)

- Acid Eluting Solution (e.g., Glycine acid solution, pH 3.0)
- Buffering Solution (e.g., Tris base solution)
- Test tubes, centrifuge

Procedure:

- Wash the patient's DAT-positive red cells thoroughly (at least 4 times) with saline to remove all unbound immunoglobulins.
- After the final wash, add a volume of Acid Eluting Solution equal to the volume of packed red cells.[\[20\]](#)
- Mix immediately and incubate at room temperature for 1-2 minutes.
- Centrifuge immediately at high speed (e.g., 3400 rpm for 60 seconds) to separate the supernatant (the eluate) from the red cell stroma.
- Immediately transfer the eluate to a clean test tube.
- Add a volume of Buffering Solution to the eluate to neutralize the pH. The eluate is now ready for antibody identification testing.[\[20\]](#)

Mandatory Visualization

Signaling Pathway of Alloimmunization

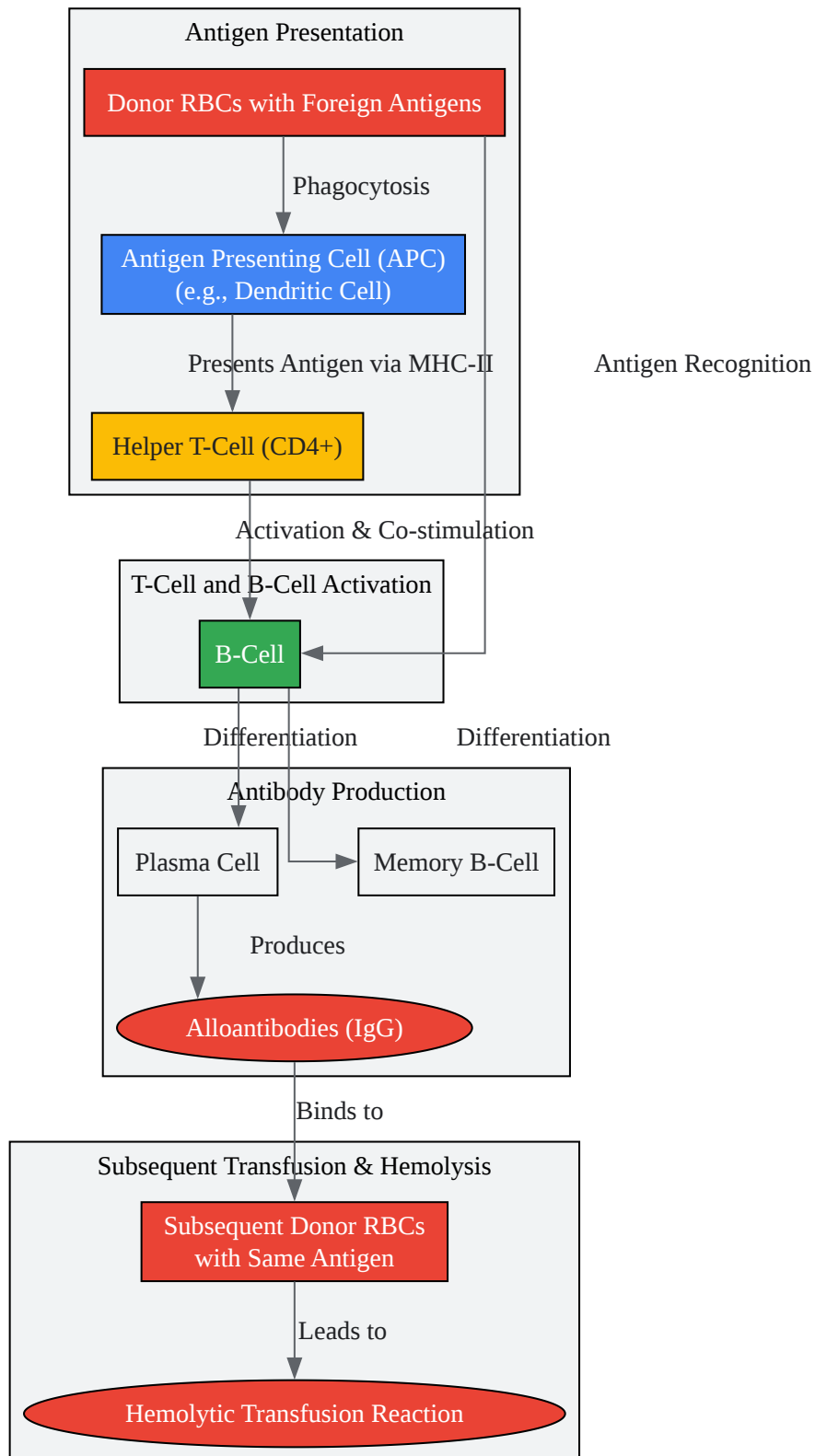

[Click to download full resolution via product page](#)

Figure 2: Simplified signaling pathway of red blood cell alloimmunization.

Need Custom Synthesis?

BenchChem offers custom synthesis for rare earth carbides and specific isotopic labeling.

Email: info@benchchem.com or [Request Quote Online](#).

References

- [1. An approach to incompatible cross-matched red cells: Our experience in a major regional blood transfusion center at Kolkata, Eastern India - PMC \[pmc.ncbi.nlm.nih.gov\]](#)
- [2. Practical Solutions for Problems in Blood Grouping and Crossmatching - PMC \[pmc.ncbi.nlm.nih.gov\]](#)
- [3. Antibody Screening: Overview, Clinical Indications/Applications, Test Performance \[emedicine.medscape.com\]](#)
- [4. Alloantibody Identification: The Importance of Temperature, Strength Reaction and Enzymes—A Practical Approach - PMC \[pmc.ncbi.nlm.nih.gov\]](#)
- [5. Learn Serology: Introduction \[learnserology.ca\]](#)
- [6. irp.cdn-website.com \[irp.cdn-website.com\]](#)
- [7. Glossary: Elution - Blood Bank Guy Glossary \[bbguy.org\]](#)
- [8. Alloimmunisation | Australian Red Cross Lifeblood \[lifeblood.com.au\]](#)
- [9. Alloimmunization From Transfusions: Background, Pathophysiology, Epidemiology \[emedicine.medscape.com\]](#)
- [10. academic.oup.com \[academic.oup.com\]](#)
- [11. thebloodproject.com \[thebloodproject.com\]](#)
- [12. tandfonline.com \[tandfonline.com\]](#)
- [13. Algorithm encompassing systematic approach in resolving incompatible crossmatches in a tertiary care center - PMC \[pmc.ncbi.nlm.nih.gov\]](#)
- [14. researchgate.net \[researchgate.net\]](#)
- [15. scribd.com \[scribd.com\]](#)
- [16. Serological Cross-Matching: Definition, Principle & Procedure | Study.com \[study.com\]](#)
- [17. labcarediagnostics.com \[labcarediagnostics.com\]](#)
- [18. laboratorytests.org \[laboratorytests.org\]](#)

- [19. scribd.com \[scribd.com\]](https://www.scribd.com)
- [20. redcross.org \[redcross.org\]](https://www.redcross.org)
- [21. Detection of alloimmunization to ensure safer transfusion practice - PMC \[pmc.ncbi.nlm.nih.gov\]](https://pubmed.ncbi.nlm.nih.gov/31111111/)
- [22. alivedx.com \[alivedx.com\]](https://www.alivedx.com)
- [23. tulipgroup.com \[tulipgroup.com\]](https://www.tulipgroup.com)
- [24. labpedia.net \[labpedia.net\]](https://www.labpedia.net)
- To cite this document: BenchChem. [Technical Support Center: Cross-matching for Multi-transfused Patients]. BenchChem, [2026]. [Online PDF]. Available at: [\[https://www.benchchem.com/product/b1167965/docs#technical-support-center-cross-matching-for-multi-transfused-patients\]](https://www.benchchem.com/product/b1167965/docs#technical-support-center-cross-matching-for-multi-transfused-patients)

Disclaimer & Data Validity:

The information provided in this document is for Research Use Only (RUO) and is strictly not intended for diagnostic or therapeutic procedures. While BenchChem strives to provide accurate protocols, we make no warranties, express or implied, regarding the fitness of this product for every specific experimental setup.

Technical Support: The protocols provided are for reference purposes. Unsure if this reagent suits your experiment?

Need Industrial/Bulk Grade? [Request Custom Synthesis Quote](#)

BenchChem

Our mission is to be the trusted global source of essential and advanced chemicals, empowering scientists and researchers to drive progress in science and industry.

Contact

Address: 3281 E Guasti Rd

Ontario, CA 91761, United States

Phone: (601) 213-4426

Email: info@benchchem.com

Contact our Ph.D. Support Team for a compatibility check