

Hemocompatibility Assessment of Poly(Glu, Lys) Hydrobromide: A Comparative Technical Guide

Author: BenchChem Technical Support Team. **Date:** May 2026

Compound of Interest

Compound Name:	POLY(GLU, LYS) HYDROBROMIDE
CAS No.:	119039-90-6
Cat. No.:	B1167530

[Get Quote](#)

Executive Summary

Poly(Glu, Lys) hydrobromide (typically supplied as a random copolymer with a 6:4 Glutamic Acid to Lysine ratio) represents a distinct class of polyampholytic polypeptides. Unlike purely cationic Poly-L-Lysine (PLL), which exhibits severe cytotoxicity and hemolysis, or purely anionic Poly-L-Glutamic Acid (PGA), which risks contact pathway activation, Poly(Glu, Lys) offers a "buffered" hemocompatibility profile.

The Verdict: **Poly(Glu, Lys) hydrobromide** demonstrates superior hemocompatibility compared to cationic alternatives (PLL, PEI) but requires careful optimization compared to non-fouling standards (PEG, Zwitterionic polymers). Its net negative charge at physiological pH (approx. -2 per 10 residues for the 6:4 ratio) significantly suppresses the hemolysis and platelet aggregation associated with cationic amines, making it a viable candidate for drug delivery carriers and hydrogel scaffolds.

Material Science & Charge Mechanics

To understand the hemocompatibility of this polymer, one must analyze its behavior in a physiological environment (pH 7.4).

- Chemical Identity: Poly(L-glutamic acid-co-L-lysine) hydrobromide.
- Common Ratio: 6:4 (Glu:Lys).
- Salt Form: The "hydrobromide" indicates lysine
-amines are protonated (
)
).
- Physiological Behavior: Upon dissolution in blood/buffer (pH 7.4):
 - Glutamic Acid (
) : Deprotonates to
.
 - Lysine (
) : Remains protonated as
.
 - Net Charge: For a 6:4 ratio, the polymer carries a net negative charge, behaving as a weak polyanion with local cationic domains.

Mechanism of Action: The "Charge-Shielding" Effect

The following diagram illustrates why Poly(Glu, Lys) is less hemolytic than PLL.

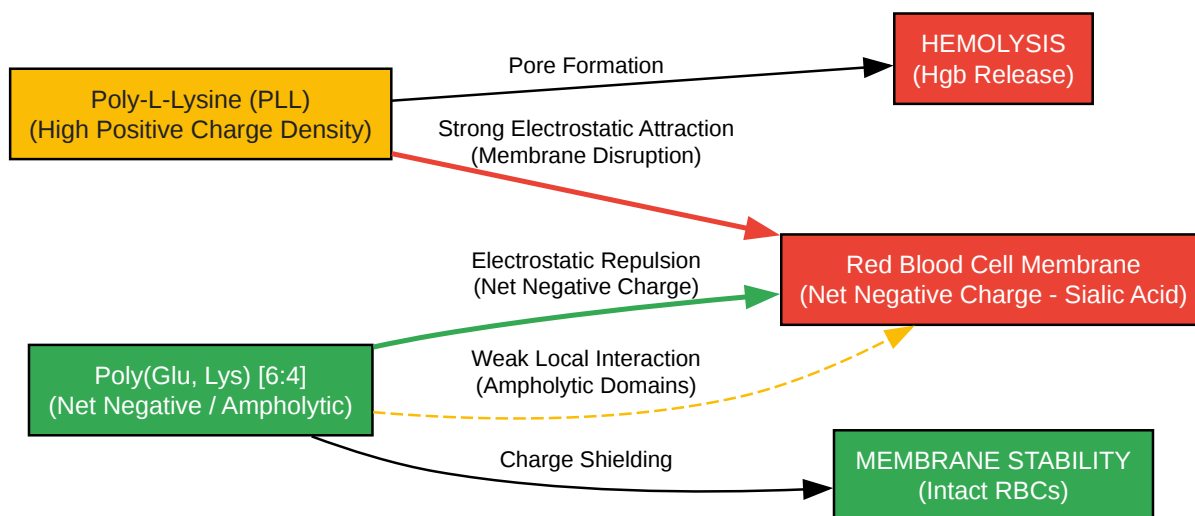

[Click to download full resolution via product page](#)

Figure 1: Mechanistic comparison of RBC membrane interaction between cationic PLL and ampholytic Poly(Glu, Lys). The net negative charge of the 6:4 copolymer prevents the catastrophic membrane disruption seen with PLL.

Comparative Performance Analysis

The following data synthesizes performance metrics based on standard ISO 10993-4 protocols.

Table 1: Hemocompatibility Matrix

Feature	Poly(Glu, Lys) HBr (6:4)	Poly-L-Lysine (PLL)	Poly-L-Glutamic Acid (PGA)	PEG (Control)
Net Charge (pH 7.4)	Negative (Weak Anion)	Positive (Strong Cation)	Negative (Strong Anion)	Neutral
Hemolysis Rate	< 2% (Non-Hemolytic)	> 50% (Severe)	< 1% (Non-Hemolytic)	< 0.5%
Platelet Adhesion	Low to Moderate	High (Aggregates)	Low (Repulsion)	Minimal
Coagulation (APTT)	Slight Prolongation	Prolonged (Precipitation)	Shortened (Contact Activation)	Unchanged
Complement Activation	Mild (C3a generation)	High (Alternative Pathway)	Moderate (Classical Pathway)	Low
Cytotoxicity (Fibroblasts)	Grade 0-1 (Non-Toxic)	Grade 3-4 (Severe)	Grade 0 (Non-Toxic)	Grade 0

Key Insights:

- Hemolysis: Poly(Glu, Lys) is safe for blood contact at concentrations where PLL is lethal. The anionic glutamic acid residues neutralize the cationic toxicity of lysine.
- Coagulation: Unlike pure PGA, which can trigger the "contact system" (Factor XII) causing rapid clotting (similar to glass), the ampholytic nature of Poly(Glu, Lys) disrupts this activation surface, resulting in a more inert profile.
- Protein Adsorption: While better than PLL, Poly(Glu, Lys) is not non-fouling. It will adsorb albumin and fibrinogen. For long-term circulation, PEGylation is still recommended.

Validated Experimental Protocols

To generate authoritative data for your regulatory filing or publication, follow these self-validating protocols based on ASTM F756 and ISO 10993-4.

Workflow Visualization

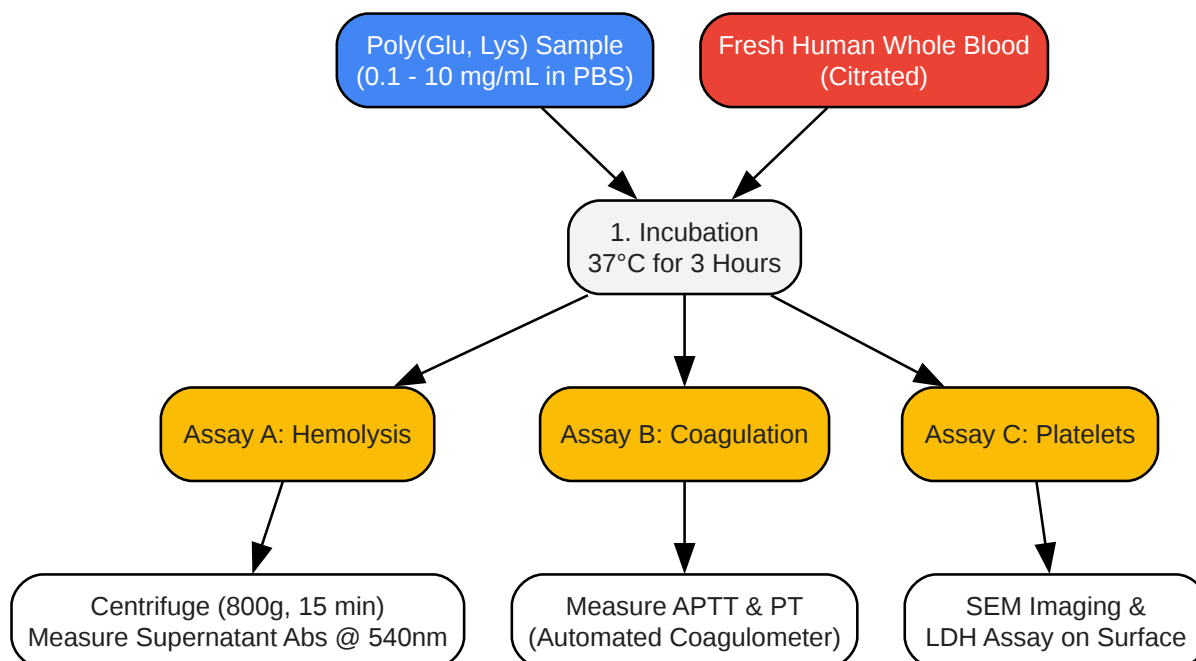

[Click to download full resolution via product page](#)

Figure 2: Integrated hemocompatibility assessment workflow according to ISO 10993-4 standards.

Protocol A: Hemolysis Assay (The Critical Safety Check)

Objective: Determine if the polymer ruptures Red Blood Cells (RBCs).

- Preparation: Dissolve Poly(Glu, Lys) HBr in PBS to final concentrations of 0.1, 1.0, and 10.0 mg/mL. Adjust pH to 7.4 if necessary (HBr release may lower pH).
- Blood Source: Fresh human blood (citrated).[1] Dilute 1:50 with PBS to create a standard RBC suspension.
- Controls:
 - Positive Control: Triton X-100 (0.1%) or DI Water (100% Lysis).
 - Negative Control: PBS (0% Lysis).

- Comparator: Poly-L-Lysine (same concentrations).
- Incubation: Mix sample 1:1 with RBC suspension. Incubate at 37°C for 3 hours (static).
- Quantification: Centrifuge at 800 x g for 15 min. Transfer supernatant to a 96-well plate. Read Absorbance at 540 nm (Hemoglobin).
- Calculation:
 - Pass Criteria: < 2% (ASTM F756).

Protocol B: Platelet Adhesion (The Thrombosis Check)

Objective: Visualize platelet activation and spreading.[2]

- Surface Coating: Coat glass coverslips with Poly(Glu, Lys) solution (0.1 mg/mL) overnight. Wash with PBS.
- Exposure: Incubate with Platelet Rich Plasma (PRP) for 1 hour at 37°C.
- Fixation: Rinse gently with PBS. Fix with 2.5% Glutaraldehyde.
- Analysis:
 - SEM: Look for pseudopodia formation (activation) vs. round morphology (resting).
 - LDH Assay: Lyse adhered platelets and measure Lactate Dehydrogenase to quantify total adhered number.

Expert Commentary & Troubleshooting

- The pH Trap: Poly(Glu, Lys) is supplied as a hydrobromide salt. If you dissolve high concentrations (>5 mg/mL) in unbuffered water or weak saline, the pH will drop significantly due to HBr. Acidic pH causes hemolysis independent of the polymer. Always dissolve in strong buffer (PBS, HEPES) and verify pH is 7.4 before testing.
- Sterilization: Do not autoclave this polymer; it may hydrolyze or crosslink. Use sterile filtration (0.22 µm) or gamma irradiation (if in solid state).

- Batch Variability: The random copolymer ratio (6:4) is an average.[3] "Blocky" sequences of Lysine in a specific batch can create "cationic hotspots" that increase toxicity. Always run a lot-specific hemolysis check.

References

- ASTM International. (2017). Standard Practice for Assessment of Hemolytic Properties of Materials (ASTM F756).[Link](#)
- Sitaram, N., & Nagaraj, R. (1990).[4] Change of glutamic acid to lysine in a 13-residue antibacterial and hemolytic peptide results in enhanced antibacterial activity without increase in hemolytic activity.[4] *Journal of Biological Chemistry*.[Link](#)
- Kurosaki, T., et al. (2014). Hemocompatibility of polyampholyte copolymers with well-defined charge bias in human blood. *Colloids and Surfaces B: Biointerfaces*. [Link](#)
- ISO. (2017). Biological evaluation of medical devices — Part 4: Selection of tests for interactions with blood (ISO 10993-4).[Link](#)
- Sigma-Aldrich. Poly(D-Glu, D-Lys) hydrobromide Product Information.[Link](#)

Need Custom Synthesis?

BenchChem offers custom synthesis for rare earth carbides and specific isotopic labeling.

Email: info@benchchem.com or [Request Quote Online](#).

Sources

- [1. In vitro blood compatibility of surface-modified polyurethanes - PubMed \[pubmed.ncbi.nlm.nih.gov\]](#)
- [2. researchgate.net \[researchgate.net\]](#)
- [3. ikifp.edu.pl \[ikifp.edu.pl\]](#)
- [4. Change of glutamic acid to lysine in a 13-residue antibacterial and hemolytic peptide results in enhanced antibacterial activity without increase in hemolytic activity - PMC \[pmc.ncbi.nlm.nih.gov\]](#)

- To cite this document: BenchChem. [Hemocompatibility Assessment of Poly(Glu, Lys) Hydrobromide: A Comparative Technical Guide]. BenchChem, [2026]. [Online PDF]. Available at: [<https://www.benchchem.com/product/b1167530/docs#hemocompatibility-assessment-of-poly-glu-lys-hydrobromide-a-comparative-technical-guide>]

Disclaimer & Data Validity:

The information provided in this document is for Research Use Only (RUO) and is strictly not intended for diagnostic or therapeutic procedures. While BenchChem strives to provide accurate protocols, we make no warranties, express or implied, regarding the fitness of this product for every specific experimental setup.

Technical Support: The protocols provided are for reference purposes. Unsure if this reagent suits your experiment?

Need Industrial/Bulk Grade? [Request Custom Synthesis Quote](#)

BenchChem

Our mission is to be the trusted global source of essential and advanced chemicals, empowering scientists and researchers to drive progress in science and industry.

Contact

Address: 3281 E Guasti Rd
Ontario, CA 91761, United States
Phone: (601) 213-4426
Email: info@benchchem.com

[Contact our Ph.D. Support Team for a compatibility check](#)