

Reproducibility of Published Studies on (S)-Manidipine: A Comparative Technical Guide

Author: BenchChem Technical Support Team. **Date:** April 2026

Compound of Interest

Compound Name: *Manidipine dihydrochloride, (S)-*

CAS No.: 119992-99-3

Cat. No.: B1166486

[Get Quote](#)

As drug development increasingly pivots toward chiral purity, the reproducibility of pharmacodynamic and pharmacokinetic studies on enantiomeric compounds becomes paramount. Manidipine, a third-generation 1,4-dihydropyridine (1,4-DHP) calcium channel blocker, is a prime example. The unsymmetrical substitution at the C4 position of its dihydropyridine ring creates a stereocenter, yielding two distinct enantiomers: (S)-Manidipine and (R)-Manidipine^[1].

This guide provides a rigorous comparison of (S)-Manidipine against its (R)-enantiomer and racemic alternatives. By deconstructing the experimental methodologies used to validate its superior efficacy, we aim to equip researchers with the mechanistic insights and self-validating protocols necessary to reproduce these critical findings.

Pharmacodynamic Superiority: The Chiral Imperative

The biological activity of 1,4-DHPs is highly stereoselective. While Hantzsch synthesis traditionally produces racemic mixtures, isolating the enantiomers reveals divergent action

profiles[1]. (S)-Manidipine acts as the active eutomer, demonstrating profound potency differences when compared to (R)-Manidipine.

Radioligand binding assays and in vivo models establish that (S)-Manidipine is approximately 30 to 80 times more potent than (R)-Manidipine in its antihypertensive action[2]. Furthermore, patch-clamp experiments reveal that the (S)-enantiomer displays a significantly faster onset of action and induces a greater magnitude of voltage-gated Ca²⁺ channel blockade than its (R)-counterpart[3].

Quantitative Comparison of Manidipine Enantiomers

To contextualize the performance of (S)-Manidipine, the following table summarizes its pharmacological metrics relative to alternative configurations.

Metric / Property	(S)-Manidipine	(R)-Manidipine	Racemic Manidipine
Relative Potency (Antihypertensive)	30x – 80x higher[2]	1x (Baseline)[2]	Intermediate
L-Type Ca ²⁺ Blockade Onset	Fast[3]	Slow[3]	Variable
[Ca ²⁺] _i Decay (Fast Phase)	Large decrease[3]	Minimal decrease[3]	Moderate decrease
Presystemic Metabolism (CYP3A4)	Lower / Stable[4]	Highly Susceptible[4]	Mixed Profile

Mechanistic Pathway of (S)-Manidipine

The primary mechanism of (S)-Manidipine involves the stereoselective blockade of voltage-gated L-type calcium channels in vascular smooth muscle. By preventing calcium influx, the drug inhibits actomyosin cross-bridging, leading to potent peripheral vasodilation with negligible cardiodepression[2].

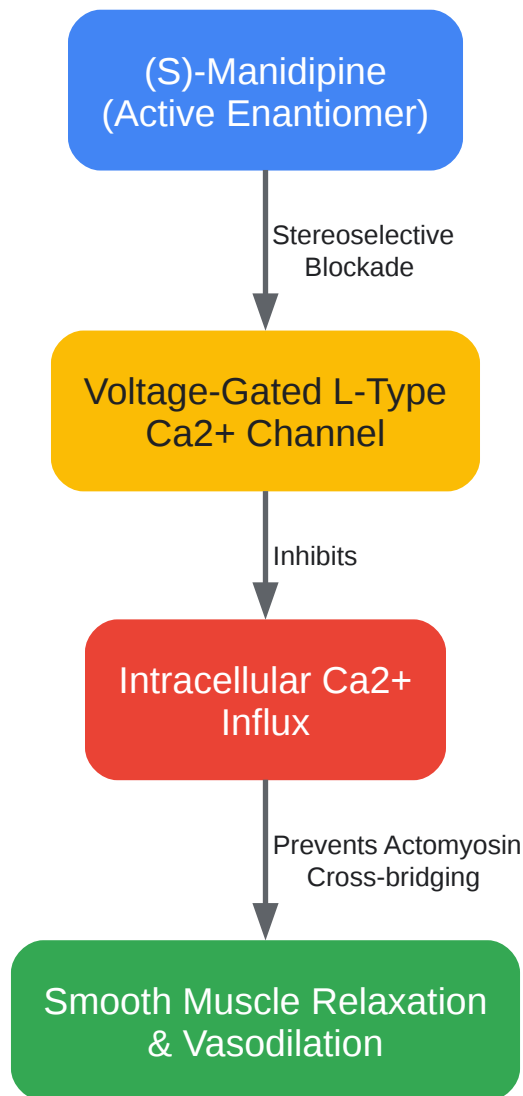

[Click to download full resolution via product page](#)

Fig 1. Stereoselective mechanism of (S)-Manidipine on L-type Ca²⁺ channels and vasodilation.

Reproducing Calcium Channel Blockade Assays

A major challenge in reproducing 1,4-DHP studies lies in the precise quantification of intracellular calcium ([Ca²⁺]_i) dynamics. The gold standard for evaluating the enantiomeric differences of Manidipine utilizes Fura-2 microfluorimetry and patch-clamp recordings on GH3 cells[3].

Experimental Workflow

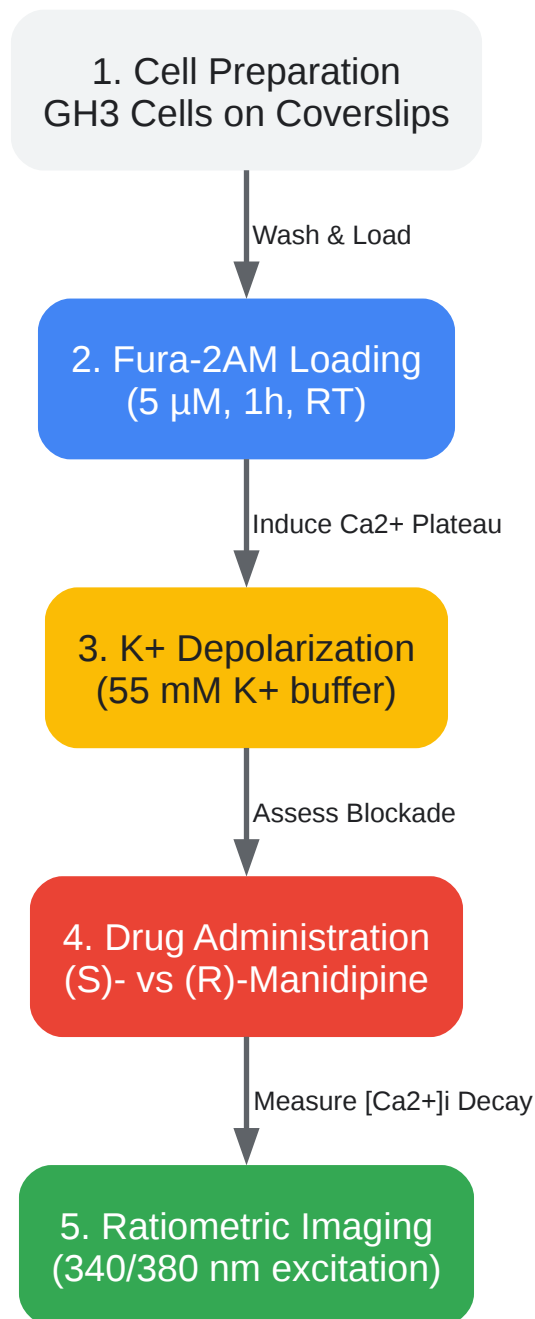

[Click to download full resolution via product page](#)

Fig 2. Experimental workflow for Fura-2 microfluorimetry to evaluate Ca²⁺ channel blockade.

Step-by-Step Methodology & Causality

To ensure a self-validating system, researchers must strictly adhere to the following protocol parameters when comparing (S)- and (R)-Manidipine:

- **Cell Culturing (The Model):** Grow GH3 (pituitary) cells on glass coverslips. Causality: GH3 cells are selected because they endogenously express high densities of voltage-sensitive Ca²⁺ channels, providing a highly responsive and reproducible model for measuring dihydropyridine blockade[3].
- **Dye Loading (The Sensor):** Load cells with 5 μM Fura-2AM in Krebs–Ringer saline solution for 1 hour at room temperature[2]. Causality: The AM (acetoxymethyl) ester allows the dye to permeate the lipid bilayer. Intracellular esterases then cleave the AM group, trapping the Ca²⁺-sensitive Fura-2 inside the cell. (Note: While some archival databases transcribe the loading concentration as 5 mM[2], standard electrophysiological protocols dictate 5 μM to prevent severe cytotoxicity and fluorescence quenching).
- **Membrane Depolarization (The Trigger):** Perfuse the cells with a depolarizing extracellular solution containing 55 mM K⁺[2]. Causality: Elevated extracellular potassium shifts the resting membrane potential, forcing voltage-gated Ca²⁺ channels into a sustained open state. This creates a stable [Ca²⁺]_i "plateau phase," against which the decay induced by Manidipine can be accurately measured[3]. Critical Step: To maintain constant osmolarity and prevent osmotic shock, extracellular Na⁺ must be proportionally reduced[2].
- **Ratiometric Microfluorimetry (The Measurement):** Illuminate the microscopic field with a Xenon Lamp, alternating between 340 nm and 380 nm excitation filters every 500 ms. Collect emitted light at 510 nm using a CCD camera[2]. Causality: Fura-2 is a ratiometric dye. Taking the ratio of emissions from 340 nm (Ca²⁺-bound) and 380 nm (Ca²⁺-free) mathematically cancels out confounding variables such as uneven dye loading, photobleaching, and variations in cell thickness.
- **System Validation (The Calibration):** Use imaging software to apply a standard calibration curve to the 340/380 ratio[2]. Causality: This converts arbitrary fluorescence units into absolute nanomolar [Ca²⁺]_i concentrations, ensuring that the biexponential decay patterns (fast and slow phases) observed between (S)- and (R)-Manidipine are universally reproducible across different laboratories[3].

Stereoselective Pharmacokinetics & Drug Interactions

Reproducibility in clinical pharmacology extends beyond the petri dish into pharmacokinetics. Like most 1,4-dihydropyridines, Manidipine is heavily metabolized by the cytochrome P450 3A4 (CYP3A4) enzyme in the intestines and liver[4].

However, the metabolism of Manidipine is highly stereoselective. Clinical interaction studies utilizing grapefruit juice (a known CYP3A4 inhibitor) reveal a significantly greater effect on the less potent (R)-enantiomer compared to the (S)-enantiomer[4].

- **The Causality:** The (R)-enantiomer undergoes a much higher degree of presystemic metabolism (first-pass effect) than (S)-Manidipine[4]. When CYP3A4 is inhibited, the plasma concentration of the (R)-enantiomer spikes disproportionately.
- **Impact on Reproducibility:** Administering racemic Manidipine in in vivo studies can lead to highly variable and unpredictable pharmacodynamic outcomes, as the ratio of active (S) to inactive (R) enantiomers will fluctuate wildly depending on the subject's basal CYP3A4 activity or diet. Utilizing purified (S)-Manidipine eliminates this metabolic variable, ensuring tighter data clustering and higher reproducibility in clinical trials.

Conclusion

The transition from racemic mixtures to enantiopure formulations represents a critical evolution in cardiovascular pharmacology. (S)-Manidipine demonstrates undeniable superiority over its (R)-enantiomer, characterized by a 30-80x increase in potency, a faster onset of L-type calcium channel blockade, and a more stable pharmacokinetic profile[2][3][4]. For researchers aiming to reproduce these findings, strict adherence to ratiometric calibration, precise osmotic balancing during depolarization, and an understanding of stereoselective CYP3A4 metabolism are non-negotiable requirements.

Need Custom Synthesis?

BenchChem offers custom synthesis for rare earth carbides and specific isotopic labeling.

Email: info@benchchem.com or [Request Quote Online](#).

Sources

- [1. Recent Approaches to Chiral 1,4-Dihydropyridines and their Fused Analogues \[mdpi.com\]](#)

- [2. MANIDIPINE, \(R\)- \[drugs.ncats.io\]](#)
- [3. Effects of manidipine and nitrendipine enantiomers on the plateau phase of K⁺-induced intracellular Ca²⁺ increase in GH3 cells - PubMed \[pubmed.ncbi.nlm.nih.gov\]](#)
- [4. Stereoselective interaction of manidipine and grapefruit juice: a new twist on an old tale - PMC \[pmc.ncbi.nlm.nih.gov\]](#)
- [To cite this document: BenchChem. \[Reproducibility of Published Studies on \(S\)-Manidipine: A Comparative Technical Guide\]. BenchChem, \[2026\]. \[Online PDF\]. Available at: \[https://www.benchchem.com/product/b1166486/docs#reproducibility-of-published-studies-on-s-manidipine-a-comparative-technical-guide\]](#)

Disclaimer & Data Validity:

The information provided in this document is for Research Use Only (RUO) and is strictly not intended for diagnostic or therapeutic procedures. While BenchChem strives to provide accurate protocols, we make no warranties, express or implied, regarding the fitness of this product for every specific experimental setup.

Technical Support: The protocols provided are for reference purposes. Unsure if this reagent suits your experiment?

Need Industrial/Bulk Grade? [Request Custom Synthesis Quote](#)

BenchChem

Our mission is to be the trusted global source of essential and advanced chemicals, empowering scientists and researchers to drive progress in science and industry.

Contact

Address: 3281 E Guasti Rd
Ontario, CA 91761, United States
Phone: (601) 213-4426
Email: info@benchchem.com

Contact our Ph.D. Support Team for a compatibility check