

# Technical Support Center: Carbohydrate Analysis Division

**Author:** BenchChem Technical Support Team. **Date:** May 2026

## Compound of Interest

Compound Name: Fructo-oligosaccharide DP11

Cat. No.: B1165458

[Get Quote](#)

Topic: Resolving Co-elution of FOS DP11 and Sucrose Isomers Ticket ID: FOS-HPAEC-001

Status: Open Support Level: Senior Application Scientist

## Executive Summary: The "Impossible" Co-elution

As a Senior Application Scientist, I often see this specific anomaly. Under normal chromatographic principles, Sucrose isomers (DP2) and FOS DP11 (Degree of Polymerization 11) should not co-elute.

- Sucrose (DP2): Weakly acidic, elutes early in HPAEC-PAD or HILIC.
- FOS DP11: Highly polar/acidic, elutes very late.

If you observe them co-eluting, you are likely experiencing a "Wrap-Around" (Carryover) Artifact. The DP11 peak you see near Sucrose is not from the current injection; it is the DP11 from the previous injection eluting during the next run's early window.

This guide provides the diagnostic logic and protocols to confirm and fix this issue.

## Part 1: Diagnostic Workflow

Before altering your method, you must confirm the source of the co-elution. Use this logic tree to diagnose the failure mode.

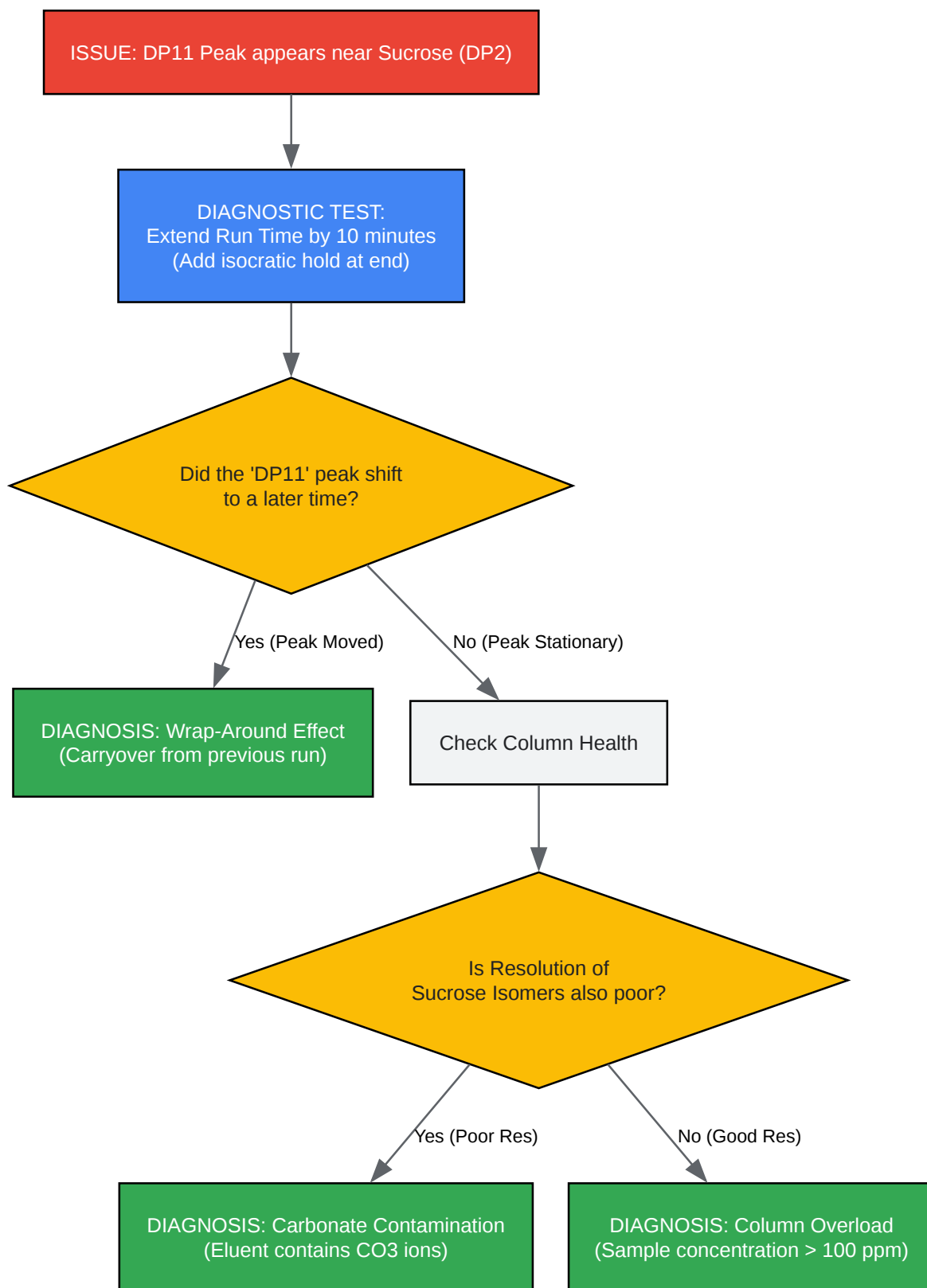

[Click to download full resolution via product page](#)

Figure 1: Diagnostic Logic Tree for Carbohydrate Co-elution. If the "DP11" peak moves when the run time changes, it is a carryover artifact.

## Part 2: The "Ghost Peak" Phenomenon (Wrap-Around)

The Mechanics: In High-Performance Anion-Exchange Chromatography (HPAEC), retention increases with chain length.

- Injection 1: Sucrose elutes at 10 min. FOS DP11 is still on the column at 30 min.
- Premature Stop: The method ends at 25 min (before DP11 elutes).
- Injection 2: The system resets. Sucrose elutes at 10 min. Simultaneously, the DP11 from Injection 1 finally exits the column, appearing as a "Ghost Peak" right next to Sucrose.

### Solution: The "Sawtooth" Gradient Wash

You must implement a high-salt wash step at the end of every injection to strip high-DP oligomers.

Recommended Gradient Profile (HPAEC-PAD on CarboPac PA200):

Time (min)	% Eluent A (100mM NaOH)	% Eluent B (100mM NaOH / 500mM NaOAc)	Action
0 - 15	90%	10%	Separation of Mono/Disaccharides (Sucrose)
15 - 30	Gradient to 40%	Gradient to 60%	Elution of FOS DP3 - DP10
30 - 35	0%	100%	Column Wash (Elutes DP11+)
35 - 50	90%	10%	Re-equilibration (CRITICAL)

Note: The wash step (30-35 min) ensures DP11 leaves the column before the next injection.

## Part 3: Optimizing Sucrose Isomer Separation

If the issue is not carryover, but actual poor resolution between Sucrose and its isomers (e.g., Turanose, Maltulose, Leucrose), the issue is Selectivity.

The Science: Sucrose and its isomers have identical molecular weights (MW 342.3). Separation in HPAEC relies on the pKa of hydroxyl groups, which varies slightly based on linkage position (e.g.,

-1,2 vs

-1,4).

Troubleshooting Protocol:

Q: My Sucrose and Turanose are merging. How do I fix this? A: Carbonate contamination acts as a "pusher" ion, compressing early peaks.

- Check Eluent: Are you using vacuum degassing? Carbon dioxide from air dissolves in NaOH to form Carbonate ( ), which is a strong eluent.
- The Fix: Install a Carbonate Removal Device (CRD) or prepare fresh eluents under Helium sparging.
- Advanced Tweak: Add Borate to the eluent. Borate forms complexes with cis-diols. Sucrose (non-reducing) does not complex strongly, while reducing isomers (Turanose) do. This alters their retention times significantly.

## Part 4: Visualizing the Correct Workflow

The following diagram illustrates the necessary gradient structure to prevent co-elution artifacts.

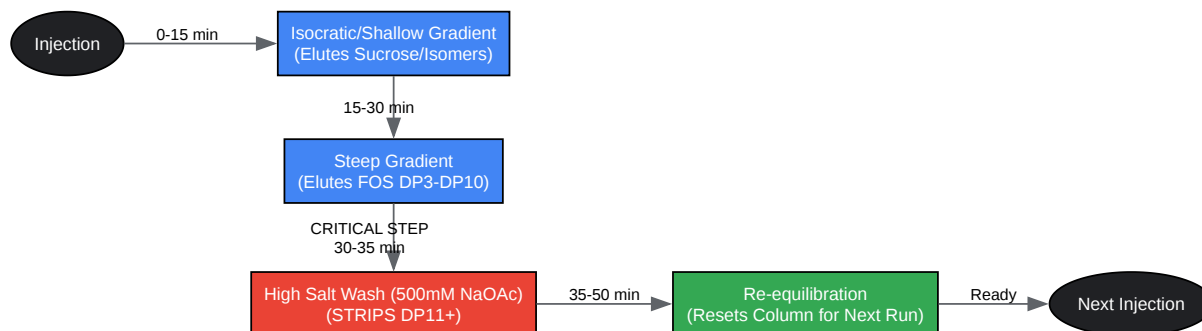

[Click to download full resolution via product page](#)

Figure 2: The "Sawtooth" Gradient Strategy. The red "Wash" step is mandatory to prevent DP11 from wrapping around into the next chromatogram.

## Part 5: Frequently Asked Questions (FAQs)

Q1: I am using HILIC (Amino Column), not HPAEC. Why are they co-eluting? A: In HILIC, retention is also DP-dependent (Low DP elutes first). If DP11 is co-eluting with Sucrose, your column's active sites may be irreversibly fouled by protein or lipid contaminants, effectively turning it into a Size Exclusion column with zero retention.

- Action: Regenerate the column with an acid wash (if polymer-based) or replace it.

Q2: Can I just stop the run earlier to save time? A: No. This is exactly what causes the wrap-around effect. You cannot "skip" the elution of DP11. It will come off eventually, usually at the worst possible time (during your next sample's sucrose peak).

Q3: Why does the peak area of "Sucrose" vary so much between injections? A: If DP11 is co-eluting (wrapping around), it is adding to the area of the Sucrose peak randomly. This destroys your quantitative accuracy. Implementing the Wash Step (Figure 2) will stabilize the Sucrose peak area.

## References

- Corradini, C., et al. (2025). Carbohydrate analysis by high-performance anion-exchange chromatography with pulsed amperometric detection: The potential is still growing. Journal of Chromatography A. Retrieved from [[Link](#)]
- Agilent Technologies. (2018). Hydrophilic Interaction Chromatography Method Development and Troubleshooting. Technical Overview. Retrieved from [[Link](#)]
- Rohrer, J.S. (2012). Troubleshooting Basics, Part IV: Peak Shape Problems. LCGC International. Retrieved from [[Link](#)]
- To cite this document: BenchChem. [Technical Support Center: Carbohydrate Analysis Division]. BenchChem, [2026]. [Online PDF]. Available at: [<https://www.benchchem.com/product/b1165458/docs#technical-support-center-carbohydrate-analysis-division>]

---

#### Disclaimer & Data Validity:

The information provided in this document is for Research Use Only (RUO) and is strictly not intended for diagnostic or therapeutic procedures. While BenchChem strives to provide accurate protocols, we make no warranties, express or implied, regarding the fitness of this product for every specific experimental setup.

**Technical Support:** The protocols provided are for reference purposes. Unsure if this reagent suits your experiment?

**Need Industrial/Bulk Grade?** [Request Custom Synthesis Quote](#)

## BenchChem

Our mission is to be the trusted global source of essential and advanced chemicals, empowering scientists and researchers to drive progress in science and industry.

#### Contact

Address: 3281 E Guasti Rd  
Ontario, CA 91761, United States  
Phone: (601) 213-4426  
Email: [info@benchchem.com](mailto:info@benchchem.com)

Contact our Ph.D. Support Team for a compatibility check