

Technical Support Center: Stabilization of Cholesteryl Linoleate Hydroperoxides for GC-MS

Author: BenchChem Technical Support Team. **Date:** May 2026

Compound of Interest

Compound Name: *Cholesteryl Linoleate Hydroperoxides*
Cat. No.: *B1163556*

[Get Quote](#)

The Thermal Paradox: Why Your Signal is Disappearing

The Elephant in the Room: You are trying to analyze a molecule (CL-OOH) that is inherently thermally unstable using a technique (GC-MS) that relies on thermal volatilization. The oxygen-oxygen bond in hydroperoxides has a dissociation energy of approximately 44 kcal/mol. Standard GC injector temperatures (250°C+) provide ample energy to homolytically cleave this bond long before the molecule reaches the detector.

The Consequence: If you inject underivatized or unreduced CL-OOH, you are not measuring the hydroperoxide. You are measuring its thermal decomposition artifacts—primarily ketones (9- and 13-oxooctadecadienoic acid cholesteryl esters) and hydroxy-epoxides.

The Solution: You cannot "gentle" the GC enough to save the native hydroperoxide. You must chemically stabilize the molecule before it enters the instrument. This guide details the Triphenylphosphine (TPP) Reduction Protocol, the industry gold standard for preserving hydroperoxide structural integrity.

Core Protocol: The TPP Reduction Method[1][2]

This workflow converts the thermally labile hydroperoxide (CL-OOH) into a thermally stable alcohol (CL-OH) without altering the cholesteryl ester backbone.

Mechanism of Action

Triphenylphosphine (TPP) selectively reduces the hydroperoxide group to a hydroxyl group. TPP itself is oxidized to triphenylphosphine oxide (TPPO). This reaction is rapid, quantitative, and occurs under mild conditions, preventing artifactual decomposition.

Step-by-Step Workflow

Reagents:

- Triphenylphosphine (TPP)[1][2]
- Chloroform/Methanol (2:1 v/v)
- BSTFA + 1% TMCS (Silylating agent)

Protocol:

- Extraction: Extract lipids from your biological matrix using the Folch method (Chloroform/MeOH). Keep samples on ice.
- Reduction (The Critical Step):
 - Add Triphenylphosphine (TPP) to the lipid extract immediately after extraction.
 - Stoichiometry: Use a 1.5x molar excess of TPP relative to estimated hydroperoxides. If unknown, a concentration of 1-5 mM TPP in the solvent is usually sufficient for biological samples.
 - Incubation: Incubate at room temperature for 30 minutes in the dark.
 - Note: TPP reduces CL-OOH to Cholesteryl Linoleate Hydroxide (CL-OH).
- Derivatization (Silylation):

- Evaporate the solvent under a stream of nitrogen.

- Reconstitute in 50

L of BSTFA + 1% TMCS.

- Incubate at 60°C for 30 minutes. This converts the newly formed -OH groups (and free cholesterol) into Trimethylsilyl (TMS) ethers, increasing volatility and thermal stability.

- Injection: Inject 1

L into the GC-MS.

Visualizing the Stabilization Pathway

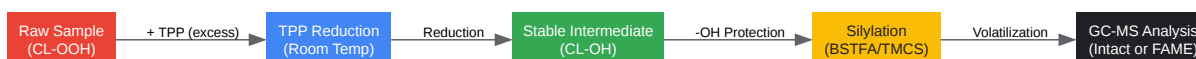

[Click to download full resolution via product page](#)

Figure 1: The stabilization workflow. By reducing the hydroperoxide early, we prevent thermal cleavage in the GC injector.

Hardware Configuration: Minimizing Thermal Stress

Even with reduced samples, cholesteryl esters are high-molecular-weight compounds (>600 Da). You must optimize the inlet to prevent discrimination and degradation.

Parameter	Recommendation	Technical Rationale
Inlet Type	PTV (Programmed Temperature Vaporization) or Cold On-Column	Avoids "flash vaporization" at 280°C. Inject cold (e.g., 40°C) and ramp temperature with the carrier gas flow to gently volatilize the heavy esters.
Liner	Deactivated, baffled liner (if PTV)	Active sites (glass wool, non-deactivated glass) catalyze dehydration of the CL-OH to conjugated dienes.
Column	High-Temp Non-Polar (e.g., DB-5ht, ZB-5ht)	Standard wax columns will bleed or degrade at the temperatures required to elute intact cholesteryl esters (320°C+).
Carrier Gas	Helium (Constant Flow)	Maintain high linear velocity to reduce residence time in the hot column.
Ionization	CI (Chemical Ionization) - Optional	If available, use Ammonia or Methane CI. EI (Electron Ionization) is harsh and often shatters the molecular ion, making identification of the specific isomer (9- vs 13-) difficult.

Troubleshooting & FAQs

Q1: I see large peaks for 9- and 13-ketocholesteryl linoleate (KODE-CE) but no hydroxides. Why?

Diagnosis: Thermal decomposition occurred before derivatization. The Fix:

- Check TPP Freshness: TPP oxidizes over time. Ensure your TPP solution is fresh.

- **Incomplete Reduction:** You likely injected the native hydroperoxide. The high injector temperature caused homolytic cleavage of the O-O bond, followed by disproportionation to the ketone.
- **Injector Temp:** If you are not using PTV, your split/splitless injector is too hot. Lower the inlet temp or switch to on-column injection.

Q2: Can I distinguish between the 9- and 13- isomers?

Answer: Yes, but primarily through the fragmentation patterns of the TMS-ether derivatives.

- **13-HODE-CE (TMS):** Look for

-cleavage ions characteristic of the silylated fragment.
- **9-HODE-CE (TMS):** Produces a distinct mass spectrum due to the position of the OTMS group relative to the double bonds.
- **Note:** If you hydrolyze to FAMES (Fatty Acid Methyl Esters) after reduction, separation is easier on standard columns (e.g., HP-88 or DB-23), but you lose the linkage information (i.e., you won't know which sterol the fatty acid was attached to).

Q3: My background noise is high. Is TPP interfering?

Answer: Yes, TPP oxidizes to TPPO (Triphenylphosphine Oxide), which elutes as a distinct, sharp peak. The Fix: TPPO is polar. If it interferes with your chromatogram, you can remove it using a short Solid Phase Extraction (SPE) step (Silica cartridge) after reduction but before GC injection. Elute the neutral lipids (cholesteryl esters) with non-polar solvents (Hexane/Ether), leaving the polar TPPO on the column.

Visualizing the Artifact Pathway (What to Avoid)

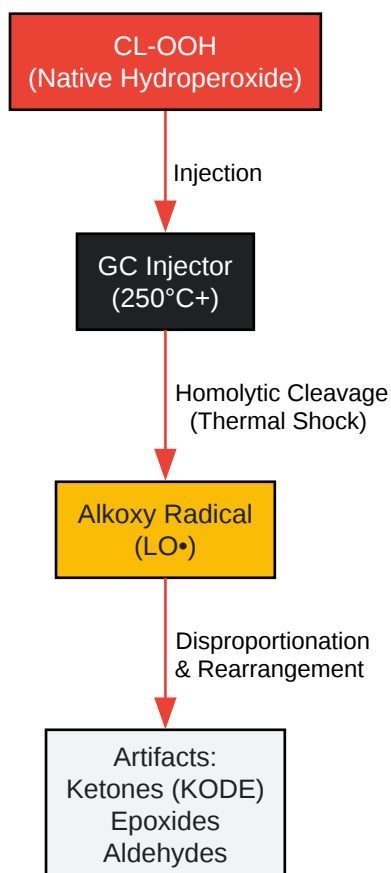

[Click to download full resolution via product page](#)

Figure 2: The decomposition pathway.[3] Without TPP reduction, the injector acts as a reactor, converting your sample into artifacts.

References

- Spitteller, G. (2001). Lipid peroxidation in aging and age-dependent diseases. *Experimental Gerontology*, 36(9), 1425-1457. [Link](#)
 - Establishes the biological context of lipid hydroperoxides and their degrad
- Hui, S. P., et al. (2007). Detection of cholesteryl ester hydroperoxide isomers using gas chromatography-mass spectrometry combined with thin-layer chromatography blotting.[4] *Analytical Biochemistry*, 361(1), 69-77. [Link](#)
 - Describes the specific methodology for analyzing cholesteryl ester hydroperoxides via GC-MS.

- Frankel, E. N. (1987). Thermal and metal-catalyzed decomposition of methyl linolenate hydroperoxides. *Journal of the American Oil Chemists' Society*, 64, 1262. [Link](#)
 - Foundational text on the thermal decomposition mechanisms of lipid hydroperoxides.
- Wiklund, P., et al. (2009).[5] Determination of hydroperoxide content in complex hydrocarbon mixtures by gas chromatography/mass spectrometry. *Analytical Sciences*, 25(3), 431-436. [Link](#)
 - Validates the Triphenylphosphine (TPP)

Need Custom Synthesis?

BenchChem offers custom synthesis for rare earth carbides and specific isotopic labeling.

Email: info@benchchem.com or [Request Quote Online](#).

Sources

- [1. researchgate.net \[researchgate.net\]](#)
- [2. A simple assay for lipid hydroperoxides based on triphenylphosphine oxidation and high-performance liquid chromatography - PubMed \[pubmed.ncbi.nlm.nih.gov\]](#)
- [3. Analytical and Structural Tools of Lipid Hydroperoxides: Present State and Future Perspectives \[mdpi.com\]](#)
- [4. Detection of cholesteryl ester hydroperoxide isomers using gas chromatography-mass spectrometry combined with thin-layer chromatography blotting - PubMed \[pubmed.ncbi.nlm.nih.gov\]](#)
- [5. Determination of hydroperoxide content in complex hydrocarbon mixtures by gas chromatography/mass spectrometry - PubMed \[pubmed.ncbi.nlm.nih.gov\]](#)
- To cite this document: BenchChem. [Technical Support Center: Stabilization of Cholesteryl Linoleate Hydroperoxides for GC-MS]. BenchChem, [2026]. [Online PDF]. Available at: [\[https://www.benchchem.com/product/b1163556/docs#technical-support-center-stabilization-of-cholesteryl-linoleate-hydroperoxides-for-gc-ms\]](https://www.benchchem.com/product/b1163556/docs#technical-support-center-stabilization-of-cholesteryl-linoleate-hydroperoxides-for-gc-ms)

Disclaimer & Data Validity:

The information provided in this document is for Research Use Only (RUO) and is strictly not intended for diagnostic or therapeutic procedures. While BenchChem strives to provide accurate protocols, we make no warranties, express or implied, regarding the fitness of this product for every specific experimental setup.

Technical Support: The protocols provided are for reference purposes. Unsure if this reagent suits your experiment?

Need Industrial/Bulk Grade? [Request Custom Synthesis Quote](#)

BenchChem

Our mission is to be the trusted global source of essential and advanced chemicals, empowering scientists and researchers to drive progress in science and industry.

Contact

Address: 3281 E Guasti Rd
Ontario, CA 91761, United States
Phone: (601) 213-4426
Email: info@benchchem.com

[Contact our Ph.D. Support Team for a compatibility check](#)