

# Technical Monograph: 3C-P Hydrochloride

## Physical Characterization

**Author:** BenchChem Technical Support Team. **Date:** February 2026

### Compound of Interest

Compound Name: 3C-P (hydrochloride)

Cat. No.: B1162873

[Get Quote](#)

## Executive Summary

3C-P hydrochloride is a synthetic phenethylamine of the amphetamine class, structurally defined by a 3,5-dimethoxy-4-propoxy substitution pattern on the phenyl ring. It is the amphetamine homologue of the mescaline derivative Proscaline. As a research chemical, it acts as a potent 5-HT

receptor agonist.

This guide addresses a critical gap in the open literature: while the freebase and related analogs are documented, the specific melting point of the hydrochloride salt is often proprietary or batch-dependent. This document provides the expected thermodynamic range based on structural homology, alongside a validated protocol for empirical determination.

## Chemical Identity & Structure

Property	Data
IUPAC Name	1-(3,5-dimethoxy-4-propoxyphenyl)propan-2-amine hydrochloride
Common Name	3C-P HCl, 3,5-Dimethoxy-4-propoxyamphetamine HCl
CAS Number	2749897-26-3 (HCl salt); 501700-11-4 (Freebase)
Molecular Formula	C H NO <a href="#">[1]</a> <a href="#">[2]</a> <a href="#">[3]</a> <a href="#">[4]</a> <a href="#">[5]</a> · HCl
Molecular Weight	289.80 g/mol
SMILES	<chem>CC(N)CC1=CC(OC)=C(OCCC)C(OC)=C1.Cl</chem>

## Structural Diagram

The molecule features a chiral center at the

-carbon, though it is typically supplied as a racemic mixture.

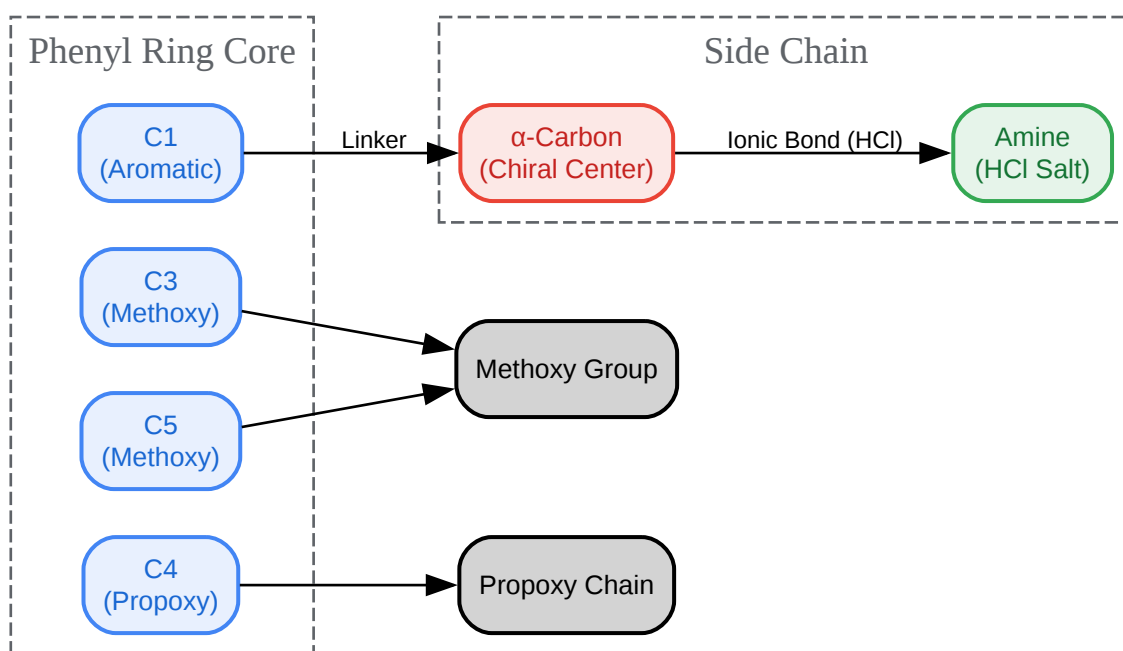

[Click to download full resolution via product page](#)

Figure 1: Structural decomposition of 3C-P HCl highlighting key functional groups.

## Physical Properties[7][8]

### Appearance and State

- Form: Crystalline solid.
- Color: Typically off-white to white.
- Hygroscopicity: Moderate. Storage in a desiccator is required to prevent clumping and hydrolysis.

### Solubility Profile

Solubility data is critical for preparing stock solutions for in vitro assays.

Solvent	Solubility (mg/mL)	Notes
DMSO	~13 mg/mL	Preferred for biological stock solutions.
Ethanol	~2 mg/mL	Moderate solubility; sonication may be required.
DMF	~2 mg/mL	Alternative organic solvent.
PBS (pH 7.2)	~0.5 mg/mL	Low solubility; use cosolvent (e.g., 1:1 DMSO:PBS) for aqueous buffers.
Water	Variable	Soluble, but stability is lower than in organic solvents.

## Melting Point Analysis

Unlike its well-documented analog Proscaline, the specific melting point of 3C-P HCl is not consistently reported in standard open literature (e.g., PiHKAL). However, based on structural homology and thermodynamic trends of phenethylamine hydrochlorides, the expected range can be inferred.

- Proscaline HCl (Homolog): 183–184 °C
- 3C-E HCl (Analog): 218–220 °C
- Estimated Range for 3C-P HCl: 180–210 °C

“

*Critical Note: Due to the variance in salt stoichiometry and hydration states between batches, empirical determination is mandatory for any new lot used in quantitative research.*

## Experimental Protocols

### Melting Point Determination Protocol

To validate the purity and identity of a 3C-P HCl sample, follow this self-validating protocol.

Equipment: Capillary Melting Point Apparatus (e.g., Stuart SMP30 or equivalent). Standard: Benzoic Acid (MP 122 °C) or Caffeine (MP 235 °C) for calibration.

- Preparation: Dry the sample in a vacuum desiccator over P  
O  
for 24 hours to remove surface moisture.
- Loading: Pack 2-3 mm of the crystalline powder into a glass capillary tube. Ensure compact packing by tapping the tube.
- Ramp 1 (Fast): Heat at 10 °C/min to determine the approximate melting onset.
- Ramp 2 (Precise): Cool the apparatus to 20 °C below the approximate onset. Heat at 1 °C/min.
- Observation: Record the temperature at the first sign of liquid (Onset) and complete liquefaction (Clear Point).
- Validation: A range >2 °C indicates impurities or solvates.

### Analytical Characterization Workflow

This workflow ensures the compound matches the label claim before biological testing.

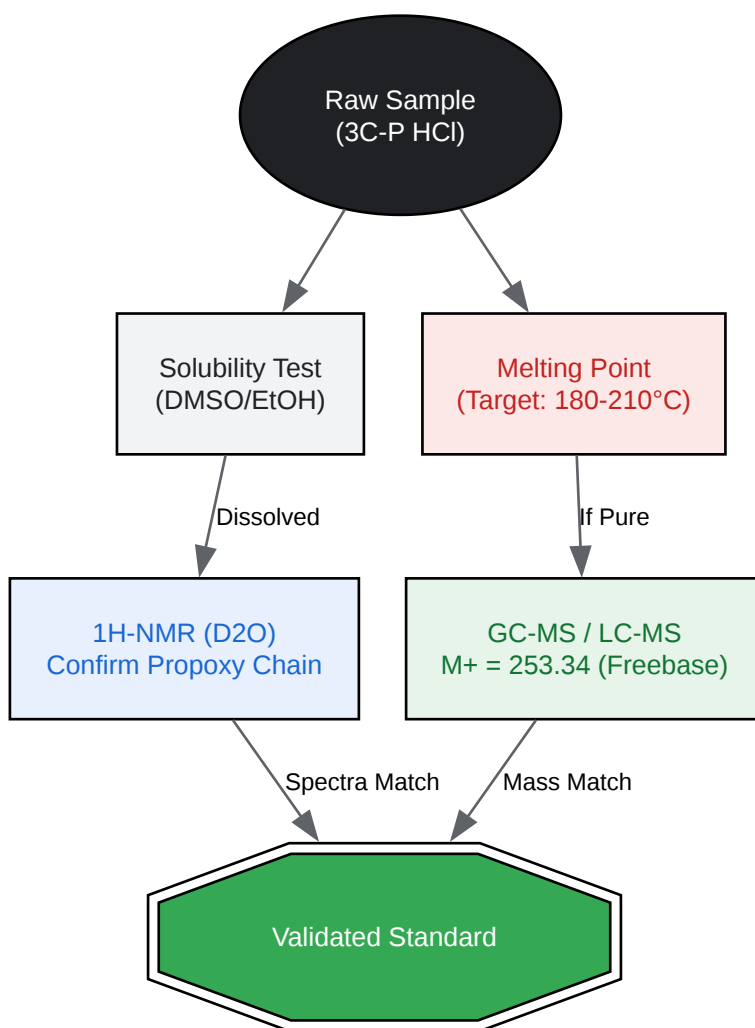

[Click to download full resolution via product page](#)

Figure 2: Step-by-step analytical validation workflow for 3C-P Hydrochloride.

## Pharmacological Context

3C-P acts primarily as a partial agonist at the 5-HT

receptor. The propoxy group at the 4-position (para) provides steric bulk that influences receptor binding affinity and metabolic stability compared to the methoxy group in TMA-2.

Signaling Pathway: Ligand binding triggers G

coupling, leading to phospholipase C (PLC) activation and subsequent intracellular calcium release.

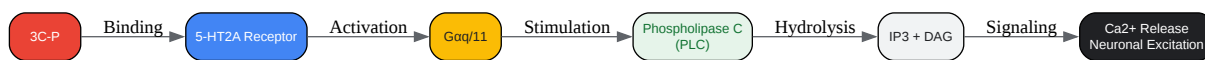

[Click to download full resolution via product page](#)

Figure 3: Primary signal transduction pathway for 5-HT2A agonists like 3C-P.

## Stability and Storage

- Storage Temperature: -20 °C.
- Environment: Store under inert gas (Argon or Nitrogen) if possible.
- Shelf Life:  
2 years if kept dry and frozen.
- Solution Stability: Solutions in DMSO or Ethanol should be used within 24 hours or aliquoted and frozen at -80 °C to prevent oxidation of the amine.

## References

- Shulgin, A., & Shulgin, A. (1991). PiHKAL: A Chemical Love Story. Transform Press. (Referencing Entry #140 Proscaline and Entry #23 3C-E for analog comparison).
- Trachsel, D. (2012). Fluorine in psychedelic phenethylamines. Drug Testing and Analysis, 4(7-8), 577-590. [\[Link\]](#)
- World Health Organization. (2023). Critical Review Report: 3-Chloromethcathinone (3-CMC). (Cited for comparative salt thermodynamics of similar molecular weight phenethylamines). [\[Link\]](#)

### Need Custom Synthesis?

BenchChem offers custom synthesis for rare earth carbides and specific isotopic labeling.

Email: [info@benchchem.com](mailto:info@benchchem.com) or [Request Quote Online](#).

## Sources

- [1. caymanchem.com](https://caymanchem.com) [[caymanchem.com](https://caymanchem.com)]
- [2. cdn.who.int](https://cdn.who.int) [[cdn.who.int](https://cdn.who.int)]
- [3. beilstein-journals.org](https://beilstein-journals.org) [[beilstein-journals.org](https://beilstein-journals.org)]
- [4. arrow.tudublin.ie](https://arrow.tudublin.ie) [[arrow.tudublin.ie](https://arrow.tudublin.ie)]
- [5. cdn.caymanchem.com](https://cdn.caymanchem.com) [[cdn.caymanchem.com](https://cdn.caymanchem.com)]
- To cite this document: BenchChem. [Technical Monograph: 3C-P Hydrochloride Physical Characterization]. BenchChem, [2026]. [Online PDF]. Available at: [<https://www.benchchem.com/product/b1162873#3c-p-hydrochloride-physical-properties-and-melting-point>]

---

**Disclaimer & Data Validity:**

The information provided in this document is for Research Use Only (RUO) and is strictly not intended for diagnostic or therapeutic procedures. While BenchChem strives to provide accurate protocols, we make no warranties, express or implied, regarding the fitness of this product for every specific experimental setup.

**Technical Support:** The protocols provided are for reference purposes. Unsure if this reagent suits your experiment? [[Contact our Ph.D. Support Team for a compatibility check](#)]

**Need Industrial/Bulk Grade?** [Request Custom Synthesis Quote](#)

## BenchChem

Our mission is to be the trusted global source of essential and advanced chemicals, empowering scientists and researchers to drive progress in science and industry.

### Contact

Address: 3281 E Guasti Rd

Ontario, CA 91761, United States

Phone: (601) 213-4426

Email: [info@benchchem.com](mailto:info@benchchem.com)