

Technical Guide: Chemical Properties & Analytical Application of Phosphamidon-d10

Author: BenchChem Technical Support Team. **Date:** April 2026

Compound of Interest

Compound Name: Phosphamidon-d10

Cat. No.: B1162552

[Get Quote](#)

Executive Summary

Phosphamidon-d10 is a deuterated isotopologue of Phosphamidon, specifically labeled with ten deuterium atoms on the N,N-diethyl moiety. It serves as a critical Internal Standard (IS) in the quantitative analysis of pesticide residues via Liquid Chromatography-Tandem Mass Spectrometry (LC-MS/MS).

By mimicking the physicochemical behavior of the target analyte while offering a distinct mass shift (+10 Da), **Phosphamidon-d10** allows researchers to correct for matrix effects, extraction inefficiencies, and ionization suppression in complex matrices (e.g., agricultural produce, water, soil).

Chemical Identity & Structural Analysis

Substance Identification

Property	Data
Chemical Name	2-Chloro-3-(diethylamino-d10)-1-methyl-3-oxoprop-1-en-1-yl dimethyl phosphate
CAS Number	13171-21-6 (Unlabeled parent CAS often used); Specific labeled CAS not assigned.
Molecular Formula	C ₁₀ H ₉ D ₁₀ ClNO ₅ P
Molecular Weight	309.75 g/mol (vs. 299.69 g/mol for native)
Isotopic Purity	Typically ≥ 98 atom % D
Chemical Purity	≥ 95% (mixture of E and Z isomers)
Appearance	Pale yellow to colorless oily liquid
Solubility	Miscible with water, alcohols, acetone, and ethyl acetate; sparingly soluble in hexane.

Structural Visualization

The following diagram illustrates the chemical structure of **Phosphamidon-d10**, highlighting the deuterated diethylamide group which provides the mass shift.

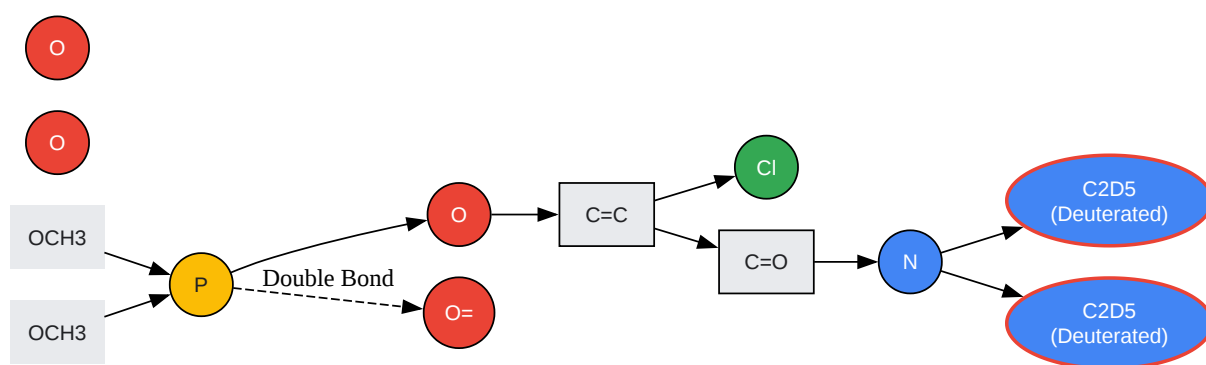

Figure 1: Structural connectivity of Phosphamidon-d10. Note the stable isotope labeling on the diethylamine moiety.

[Click to download full resolution via product page](#)

Analytical Application: LC-MS/MS

Mechanism of Internal Standardization

Phosphamidon-d10 is ideal for Isotope Dilution Mass Spectrometry (IDMS). Because deuterium labeling on the alkyl (ethyl) groups is chemically stable and non-exchangeable in aqueous solution, the standard co-elutes (or elutes very close) to the native analyte, experiencing the exact same ionization suppression or enhancement from the sample matrix.

Mass Spectrometry Transitions (MRM)

In a Triple Quadrupole (QqQ) system operating in Positive Electrospray Ionization (ESI+) mode, the following transitions are standard.

Analyte	Precursor Ion ()	Product Ion 1 (Quantifier)	Product Ion 2 (Qualifier)	Collision Energy (eV)
Phosphamidon (Native)	300.1	127.0	72.1	15 - 25
Phosphamidon-d10	310.2	127.0	82.1	15 - 25

- Transition Logic:
 - 310.2
127.0: The fragment at 127 typically corresponds to the dimethyl phosphate moiety or a chlorinated rearrangement product that does not contain the diethylamide group. Thus, it retains the native mass.[1]
 - 310.2
82.1: The fragment at

82 corresponds to the deuterated diethylamine cation

. The native equivalent is

72. This shift of +10 Da confirms the presence of the labeled moiety.

Experimental Protocol: QuEChERS Extraction

The following workflow describes a validated method for extracting Phosphamidon from vegetable matrices using **Phosphamidon-d10** as the surrogate internal standard.

Reagents & Materials[1][2][3][4]

- Stock Solution: 100 µg/mL **Phosphamidon-d10** in Acetonitrile (store at -20°C).
- Extraction Salts: 4g MgSO₄, 1g NaCl.
- dSPE Clean-up: 150mg MgSO₄, 25mg PSA (Primary Secondary Amine).

Step-by-Step Workflow

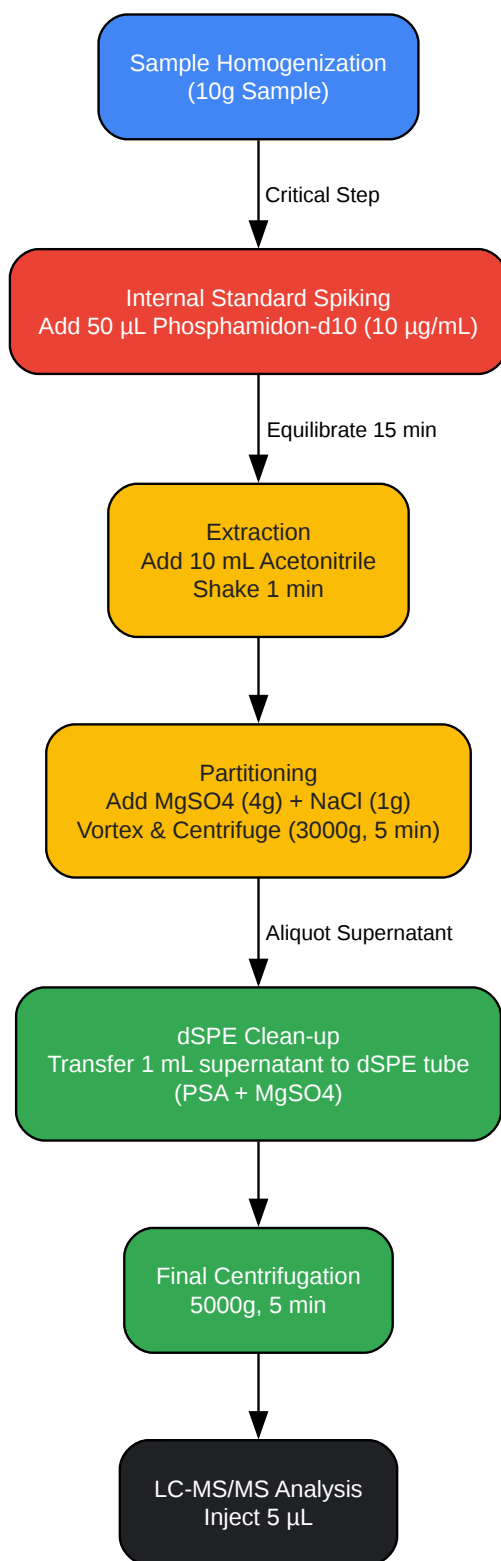

Figure 2: QuEChERS extraction workflow utilizing Phosphamidon-d10.

[Click to download full resolution via product page](#)

[2][3]

Protocol Notes

- **Spiking Timing:** The IS must be added before extraction solvent is applied to the sample. This ensures the IS experiences the same extraction efficiency losses as the native analyte.
- **pH Sensitivity:** Phosphamidon is susceptible to hydrolysis in alkaline conditions. Ensure the extraction environment remains neutral or slightly acidic (buffered QuEChERS kits using Citrate or Acetate are recommended).

Stability & Handling

- **Storage:** Store neat material and stock solutions at -20°C or lower. Protect from light and moisture.
- **Stability:**
 - **Solid/Neat:** Stable for >2 years if stored properly.
 - **Solution (Acetonitrile):** Stable for 6-12 months at -20°C.
 - **Aqueous/Alkaline:** Unstable. Degrades rapidly at pH > 8.
- **Safety: Phosphamidon-d10** retains the toxicity profile of the parent compound. It is a potent cholinesterase inhibitor.
 - **PPE:** Wear nitrile gloves, safety goggles, and a lab coat. Handle only in a fume hood.
 - **Disposal:** Treat as hazardous organic waste containing organophosphates.

References

- PubChem. (n.d.). Phosphamidon Compound Summary. National Library of Medicine. Retrieved from [\[Link\]](#)
- European Commission. (2021). EU Reference Laboratories for Residues of Pesticides: Analytical Methods. Retrieved from [\[Link\]](#)

- Agilent Technologies. (2017).[4] Improved LC/MS/MS Pesticide Multiresidue Analysis Using Triggered MRM. Application Note. Retrieved from [[Link](#)]

Need Custom Synthesis?

BenchChem offers custom synthesis for rare earth carbides and specific isotopic labeling.

Email: info@benchchem.com or [Request Quote Online](#).

Sources

- 1. cdpr.ca.gov [cdpr.ca.gov]
- 2. researchgate.net [researchgate.net]
- 3. researchgate.net [researchgate.net]
- 4. [agilent.com](https://www.agilent.com) [[agilent.com](https://www.agilent.com)]
- To cite this document: BenchChem. [Technical Guide: Chemical Properties & Analytical Application of Phosphamidon-d10]. BenchChem, [2026]. [Online PDF]. Available at: [<https://www.benchchem.com/product/b1162552/docs#technical-guide-chemical-properties-analytical-application-of-phosphamidon-d10>]

Disclaimer & Data Validity:

The information provided in this document is for Research Use Only (RUO) and is strictly not intended for diagnostic or therapeutic procedures. While BenchChem strives to provide accurate protocols, we make no warranties, express or implied, regarding the fitness of this product for every specific experimental setup.

Technical Support: The protocols provided are for reference purposes. Unsure if this reagent suits your experiment?

Need Industrial/Bulk Grade? [Request Custom Synthesis Quote](#)

BenchChem

Our mission is to be the trusted global source of essential and advanced chemicals, empowering scientists and researchers to drive progress in science and industry.

Contact

Address: 3281 E Guasti Rd

Ontario, CA 91761, United States

Phone: (601) 213-4426

Email: info@benchchem.com

[Contact our Ph.D. Support Team for a compatibility check](#)