

optimizing dissolution dynamic nuclear polarization for ¹³C gluconate

Author: BenchChem Technical Support Team. **Date:** February 2026

Compound of Interest

Compound Name: Sodium D-Gluconate-1-¹³C

Cat. No.: B1161275

[Get Quote](#)

Application Note: Optimization of Dissolution Dynamic Nuclear Polarization (d-DNP) for [1-¹³C]Gluconate

Executive Summary

This application note details the optimized protocol for the preparation, polarization, and dissolution of [1-¹³C]Gluconate. Unlike the widely used [1-¹³C]Pyruvate, [1-¹³C]Gluconate serves as a specific probe for the Pentose Phosphate Pathway (PPP), a metabolic route upregulated in oxidative stress, ischemia, and aggressive tumorigenesis.

The primary challenge with [1-¹³C]Gluconate is its relatively short spin-lattice relaxation time (s at 3T) compared to pyruvate (s). This necessitates a highly optimized "sample-to-vein" workflow. This guide provides a self-validating system to maximize polarization () and minimize transport losses.

Metabolic Context & Mechanism

To interpret the imaging data, researchers must understand the metabolic fate of the probe. [1-¹³C]Gluconate (often administered as the lactone or neutralized acid) enters the cell and is phosphorylated to 6-Phosphogluconate (6-PG).

The critical imaging event is the decarboxylation of 6-PG by 6-Phosphogluconate Dehydrogenase (6PGD). This reaction releases the C1 label as hyperpolarized

(which rapidly equilibrates to H

), serving as a direct biomarker for PPP flux and NADPH production.

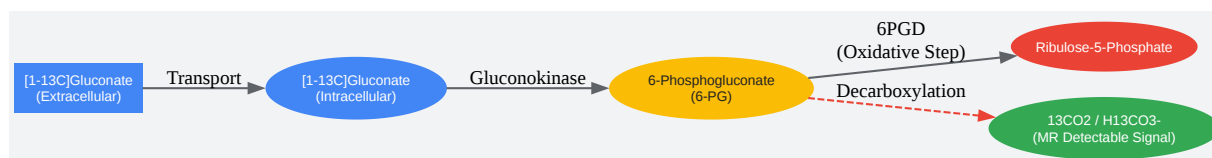

[Click to download full resolution via product page](#)

Figure 1: Metabolic fate of [1-13C]Gluconate. The appearance of H

CO

indicates active flux through 6PGD.

Protocol Phase I: Sample Formulation

The physics of DNP requires an amorphous glass at cryogenic temperatures (~1.2 K). Crystallization destroys the DNP effect.

Reagents

- Substrate: [1-13C]Gluconic Acid (49-50% w/w aqueous solution) OR Sodium [1-13C]Gluconate (Solid).
 - Recommendation: Use Sodium [1-13C]Gluconate solid for higher concentration control, dissolved in a glycerol/water matrix.
- Radical: OX063 Trityl Radical.
 - Why: Trityl radicals have a narrow EPR linewidth suited for direct polarization of C carbonyls without proton assistance (Direct DNP).

- Glassing Agent: Glycerol.[1]
- Paramagnetic Dopant: Gadolinium chelate (e.g., ProHance/Gadoteridol).
 - Why: Shortens electron

, increasing polarization buildup rate.

Formulation Table

Component	Concentration / Ratio	Function
[1-13C]Na-Gluconate	2.0 M (in solvent)	Target Nucleus
Solvent Matrix	Glycerol : Water (50:50 v/v)	Glassing Agent
OX063 Radical	15.0 mM	Electron Source
Gd (ProHance)	1.0 - 1.5 mM	Relaxation Switch

Preparation Steps

- Weighing: Weigh [1-13C]Sodium Gluconate into a micro-centrifuge tube.
- Solvation: Add the 50:50 Glycerol/Water mixture. Vortex heavily and sonicate at 40°C until fully dissolved. Note: Gluconate is viscous; ensure no crystals remain.
- Radical Addition: Add pre-weighed OX063 radical to achieve 15 mM. Vortex until a dark green, homogeneous syrup is formed.
- Doping: Add Gd

stock solution to reach 1.5 mM.
- Aliquoting: Dispense 30–50

L aliquots into DNP sample cups. Flash freeze in liquid nitrogen to verify glass formation (sample must remain transparent, not opaque white).

Protocol Phase II: Polarization (DNP Physics)

- Instrument: HyperSense, SpinLab, or custom 3.35T / 5T polarizer.
- Temperature:

K.
- Microwave Frequency: 94.005 GHz (at 3.35T) or 140 GHz (at 5T). Note: Exact center frequency varies by radical batch and magnet drift.

Optimization Routine (Frequency Sweep)

Do not rely on a fixed frequency. Perform a microwave frequency sweep on the first sample of a new batch:

- Set frequency to 93.900 GHz.
- Increment by 10 MHz steps.
- Monitor

C signal buildup for 2 minutes at each step.
- Target: Select the frequency yielding the highest positive polarization slope (). For OX063/Gluconate, this is typically 94.090

0.010 GHz (on 3.35T systems).

Buildup Time: Typical buildup to saturation takes 60–90 minutes.

Protocol Phase III: Dissolution & Neutralization

This is the most critical step. You are racing against a

of ~20 seconds.

Dissolution Media

The goal is to dilute the hyperpolarized sample to a physiological concentration (typically 40–80 mM) and pH (7.4) instantly.

- Base: Sodium Hydroxide (NaOH) is not needed if starting with Sodium Gluconate (Salt). If starting with Gluconic Acid, NaOH is mandatory.

- Buffer: 40 mM Tris or HEPES.

- Chelator: 0.3 mM EDTA (sequesters Gd

to prevent

shortening in liquid state).

- Solvent:

(Deuterium Oxide).

- Why:

extends

by reducing dipole-dipole relaxation interactions compared to

.

The Dissolution Recipe (Standard 4 mL Output)

- Sample: 40

L of 2M [1-¹³C]Gluconate prep.

- Dissolution Volume: 4.0 mL.

- Media Composition:

- : 4.0 mL

- Tris Buffer: 100 mg (solid) pre-dissolved.

- HCl: Titrate media to pH 7.4 before loading into the polarizer.

- Temperature: Heat to 170°C / 10 bar pressure (standard superheated water method).

Workflow Diagram

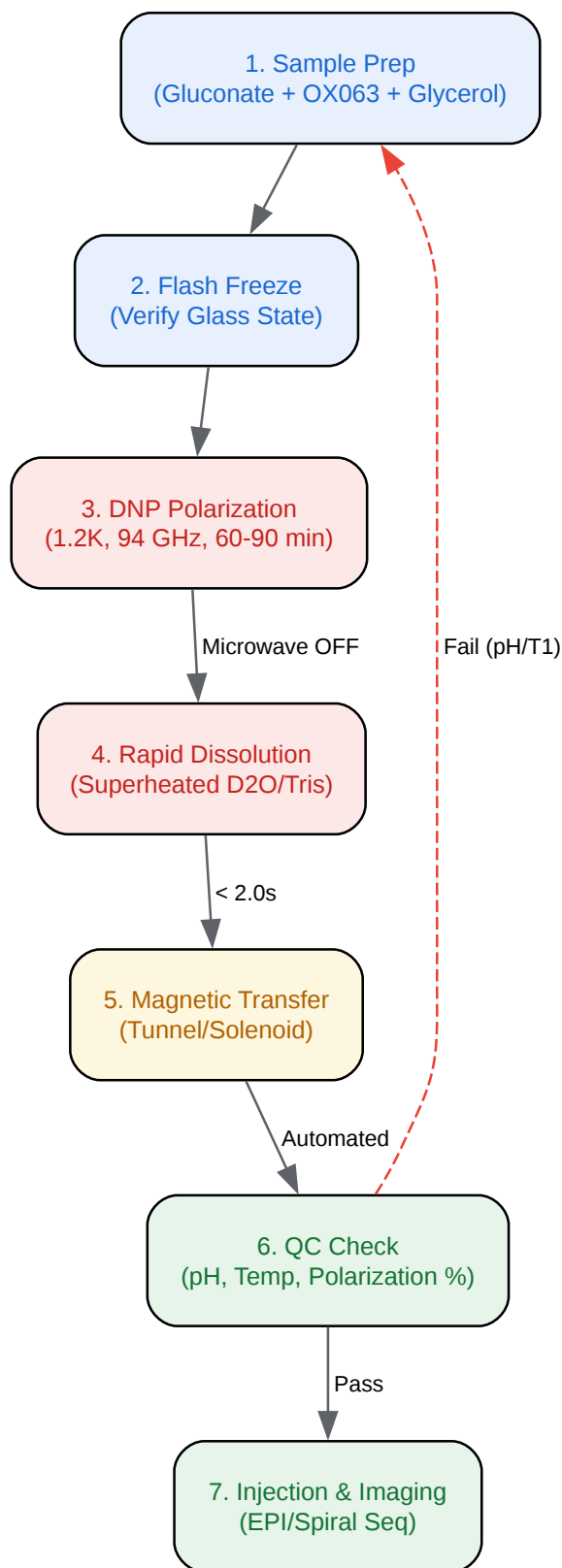

[Click to download full resolution via product page](#)

Figure 2: Optimized DNP "Sample-to-Vein" Workflow. Note the critical <2.0s transfer time.

Quality Control (QC) & Troubleshooting

Every dissolution must be validated before animal/human injection.

Mandatory QC Parameters

Parameter	Acceptance Criteria	Method
pH		pH strip or micro-electrode
Temperature		IR Thermometer
Volume		Visual check
Polarization		Low-flip angle NMR pulse on spectrometer
Radical Filtration	Undetectable	0.2 m filter inline

Troubleshooting Low Polarization

- Issue: Opaque white sample after freezing.
 - Cause: Crystallization. The radical is excluded from the lattice, preventing DNP.
 - Fix: Increase Glycerol content or reduce Gluconate concentration.
- Issue: Fast decay (Short) after dissolution.
 - Cause: Residual paramagnetic impurities (or Gd).

- Fix: Degas dissolution media with Helium; ensure EDTA is present to chelate Gd

Data Acquisition Strategy

Due to the short

of gluconate (~20s at 3T), standard CSI (Chemical Shift Imaging) is often too slow.

- Sequence: Spectral-Spatial Excitation or EPSI (Echo-Planar Spectroscopic Imaging).
- Flip Angle: Variable Flip Angle (VFA) scheme is recommended to utilize magnetization efficiently over the 60-second metabolic window.
- Start Time: Imaging must commence immediately upon injection (t=0) to capture the initial vascular flush and subsequent metabolic conversion.

References

- Mishkovsky, M., et al. (2017). Hyperpolarized -[1-13C]gluconolactone as a probe of the pentose phosphate pathway. Proceedings of the National Academy of Sciences. [\[Link\]](#)
- Ardenkjaer-Larsen, J. H., et al. (2003). Increase in signal-to-noise ratio of > 10,000 times in liquid-state NMR. Proceedings of the National Academy of Sciences. [\[Link\]](#)
- Wolber, J., et al. (2004). Generating highly polarized nuclear spins in solution using dynamic nuclear polarization. Nuclear Instruments and Methods in Physics Research Section A. [\[Link\]](#)
- Comment, A., & Merritt, M. E. (2014). Hyperpolarized Magnetic Resonance as a Sensitive Detector of Metabolic Function.[\[2\]](#)[\[3\]](#) Biochemistry.[\[4\]](#) [\[Link\]](#)
- Kurhanewicz, J., et al. (2011). Analysis of Cancer Metabolism by Imaging Hyperpolarized Nuclei. Neoplasia. [\[Link\]](#)

Need Custom Synthesis?

BenchChem offers custom synthesis for rare earth carbides and specific isotopic labeling.

Email: info@benchchem.com or [Request Quote Online](#).

Sources

- [1. Stable electron-irradiated \[1-13C\]alanine radicals for metabolic imaging with dynamic nuclear polarization - PMC \[pmc.ncbi.nlm.nih.gov\]](#)
- [2. researchgate.net \[researchgate.net\]](#)
- [3. mriquestions.com \[mriquestions.com\]](#)
- [4. researchgate.net \[researchgate.net\]](#)
- To cite this document: BenchChem. [optimizing dissolution dynamic nuclear polarization for 13C gluconate]. BenchChem, [2026]. [Online PDF]. Available at: [\[https://www.benchchem.com/product/b1161275#optimizing-dissolution-dynamic-nuclear-polarization-for-13c-gluconate\]](https://www.benchchem.com/product/b1161275#optimizing-dissolution-dynamic-nuclear-polarization-for-13c-gluconate)

Disclaimer & Data Validity:

The information provided in this document is for Research Use Only (RUO) and is strictly not intended for diagnostic or therapeutic procedures. While BenchChem strives to provide accurate protocols, we make no warranties, express or implied, regarding the fitness of this product for every specific experimental setup.

Technical Support: The protocols provided are for reference purposes. Unsure if this reagent suits your experiment? [[Contact our Ph.D. Support Team for a compatibility check](#)]

Need Industrial/Bulk Grade? [Request Custom Synthesis Quote](#)

BenchChem

Our mission is to be the trusted global source of essential and advanced chemicals, empowering scientists and researchers to drive progress in science and industry.

Contact

Address: 3281 E Guasti Rd

Ontario, CA 91761, United States

Phone: (601) 213-4426

Email: info@benchchem.com