

# Technical Guide: Mechanism of UV-Induced Polymerization of 5,7-Diynoic Lipids

**Author:** BenchChem Technical Support Team. **Date:** April 2026

## Compound of Interest

Compound Name: *5,7-Docosadiynoic Acid Ethyl Ester-d5*  
Cat. No.: *B1161692*

[Get Quote](#)

Content Type: Technical Whitepaper Audience: Researchers, Formulation Scientists, and Drug Development Professionals Focus: Mechanistic principles, topochemical requirements, and experimental protocols for 5,7-diynoic acid (5,7-DA) based systems.

## Executive Summary: The 5,7-Diynoic Advantage

In the landscape of polymerizable lipids, 5,7-diynoic lipids (e.g., 5,7-docosadiynoic acid) occupy a distinct functional niche compared to their more common 10,12-counterparts (e.g., PCDA). The defining feature of the 5,7-isomer is the proximity of the photo-reactive diyne moiety to the hydrophilic headgroup.

This short alkyl spacer (C1-C4) creates a rigid mechanical coupling between the surface of the lipid assembly and the polymer backbone. Consequently, 5,7-diynoic lipids exhibit heightened sensitivity to surface perturbations, making them superior candidates for mechanochromic sensing and targeted drug release systems where external stimuli (pH, ligand binding) must rapidly transduce into backbone conformational changes.

This guide details the topochemical mechanism driving this polymerization, the specific structural requirements for the 5,7-isomer, and a validated protocol for synthesizing

polydiacetylene (PDA) liposomes.

## Mechanism of UV-Induced Polymerization

The formation of polydiacetylene (PDA) from 5,7-diyne monomers is not a random radical chain reaction but a topochemical polymerization. It proceeds via a 1,4-addition reaction that is strictly controlled by the crystal lattice packing of the monomers.

### The 1,4-Addition Pathway

Upon irradiation with UV light (specifically

nm), the diyne monomers (

) undergo a transition to a conjugated ene-yne polymer backbone.

- **Initiation:** A photon is absorbed by the diyne unit, generating a dicarbene or diradical intermediate in the excited state.
- **Propagation:** The intermediate reacts with the adjacent monomer at the C1 and C4 positions. This forms a new single bond between monomers, converting the two triple bonds of the monomer into an alternating double-triple bond sequence in the polymer.
- **Termination:** The chain grows until it encounters a lattice defect or grain boundary.

**Key Mechanistic Insight:** Unlike solution-phase polymerization, this reaction does not require an external initiator. The lattice itself acts as the template. If the lattice is disrupted (e.g., by melting or solvent intercalation), polymerization halts immediately.

### Visualization of the Reaction Pathway



[Click to download full resolution via product page](#)

Caption: The topochemical pathway from monomer to chromatic polymer. Note that the reaction is confined strictly to the ordered solid/gel phase.

## Structural & Topochemical Requirements[1][2][3]

For 5,7-diyne lipids to polymerize, they must self-assemble into a specific geometric arrangement. The "packing parameters" are non-negotiable; if the lipids are in a liquid-crystalline (fluid) phase, the reactive centers will never align sufficiently for the reaction to occur.

### The Geometric Postulates

Based on Baughman's principles for solid-state polymerization, the 5,7-diyne monomers must align with the following parameters:

Parameter	Optimal Value	Tolerance Range	Consequence of Deviation
Inter-monomer Distance ( )	4.9 Å	4.7 – 5.2 Å	Reaction fails (radicals cannot bridge gap).
Tilt Angle ( )	45°	40° – 50°	Prevents C1-C4 orbital overlap.
**Contact Distance ( )	3.5 Å	< 4.0 Å	Critical for 1,4-addition initiation.

### The "Spacer Effect" in 5,7-Isomers

In 5,7-diyne lipids, the diyne group is located at carbons 5 and 7 relative to the carboxyl headgroup.

- Rigidity: The short ethylene spacer (

) between the headgroup and the diyne reduces the motional freedom of the headgroup.

- Impact: This makes the polymerization highly sensitive to headgroup interactions (e.g., hydrogen bonding, pH changes). It also means that 5,7-lipids often require lower temperatures to maintain the necessary gel-phase packing compared to 10,12-lipids, which have a longer, more flexible "buffer" zone.

## Packing Alignment Diagram

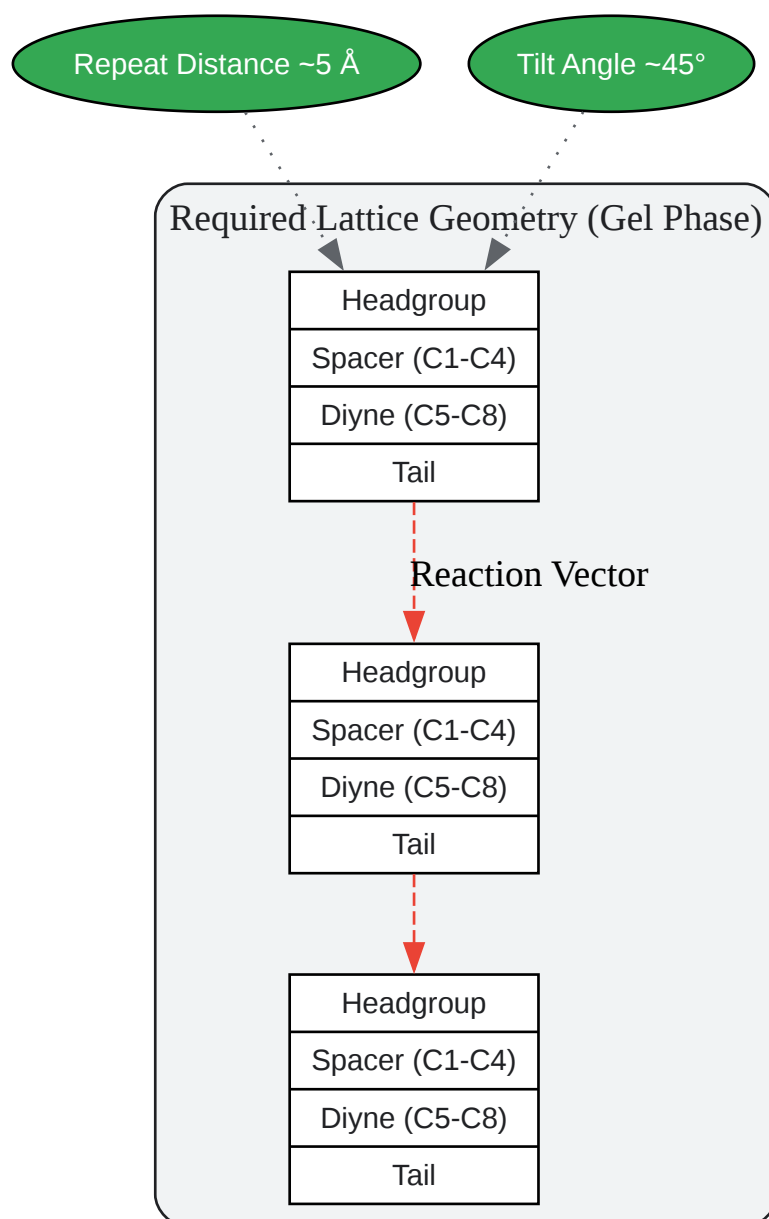

[Click to download full resolution via product page](#)

Caption: Schematic of the spatial alignment required for 5,7-diynoic lipids. The C5-C8 diyne units must stack with a  $\sim 5$  Å translation vector.

## Validated Experimental Protocol

This protocol is designed for 5,7-docosadiynoic acid (5,7-DCDA) but is adaptable to other 5,7-derivatives.

Objective: Synthesize uniform, polymerized liposomes with a high "Blue Phase" yield.

## Materials

- Lipid: 5,7-Docosadiynoic acid (ensure >98% purity).
- Solvent: Chloroform (HPLC grade).
- Buffer: HEPES (10 mM, pH 7.4) or Deionized Water (18.2 MΩ).
- Equipment: Rotary evaporator, Probe sonicator, UV Crosslinker (254 nm, 8 watts).

## Step-by-Step Workflow

- Film Formation:
  - Dissolve lipid in chloroform to a concentration of 2-5 mM.
  - Evaporate solvent under reduced pressure (rotary evaporator) at 40°C.
  - Critical: Dry the film overnight under high vacuum to remove trace solvent, which can disrupt packing.
- Hydration & Assembly:
  - Hydrate the film with pre-warmed buffer (above the lipid's  $T_m$ , typically >50°C for DCDA).
  - Sonicate (probe tip) at 60-70°C for 15 minutes (pulsed mode) to form Small Unilamellar Vesicles (SUVs). The solution should be clear/translucent.

- Lattice Ordering (The "Annealing" Step):
  - Crucial for 5,7-lipids: Store the liposome suspension at 4°C for at least 12-24 hours.
  - Why: This cooling period forces the lipids into the ordered gel phase ( ), allowing the diyne groups to align according to the geometric postulates described in Section 3.1.
- Polymerization:
  - Place the sample on ice (maintain 4°C).
  - Irradiate with 254 nm UV light.<sup>[1]</sup>
  - Dose: 1 J/cm<sup>2</sup> total energy (typically 2-5 minutes depending on lamp intensity).
  - Observation: The solution creates a deep blue color immediately.
- Quality Control (QC):
  - UV-Vis: Check absorbance.<sup>[2]</sup> A sharp peak at ~640-650 nm confirms the "Blue Phase" (polymerized, ordered).
  - Size: DLS should show diameter ~100-150 nm with PDI < 0.2.

## Workflow Diagram

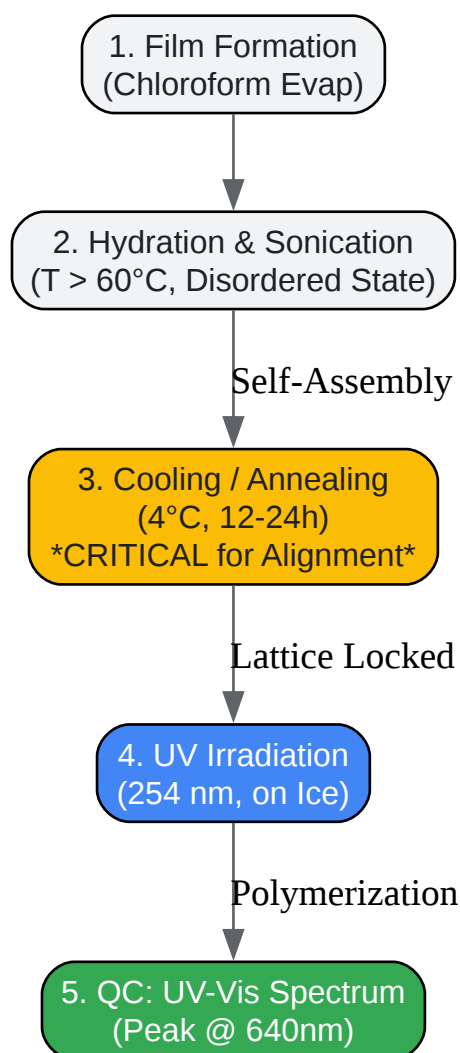

[Click to download full resolution via product page](#)

Caption: Experimental workflow for generating polymerized 5,7-diyonic liposomes. Step 3 is the most critical failure point if skipped.

## Chromatic Properties & Applications

The utility of 5,7-diyonic polymers lies in their chromatic transition.

### The Blue-to-Red Transition

- Blue Phase: The initial polymer has a planar, fully conjugated backbone. The -electron delocalization is maximized.

- Red Phase: External stress (heat, pH change, or ligand binding at the headgroup) induces a rotation around the C-C single bonds of the backbone. This breaks the planarity, reduces the effective conjugation length, and shifts absorbance to lower wavelengths (~540 nm).

## Why 5,7-Lipids are Superior Sensors

Because the diyne is at the 5,7 position (closer to the surface), the "lever arm" is shorter. A binding event at the headgroup (e.g., a virus binding to a glycolipid dopant) exerts more direct torque on the polymer backbone compared to 10,12-lipids.

Data Comparison:

Feature	5,7-Diynoic Lipids	10,12-Diynoic Lipids
Spacer Length	Short (C1-C4)	Long (C1-C9)
Headgroup Coupling	Rigid / High	Flexible / Moderate
Sensitivity	High (Rapid Blue-to-Red)	Moderate (Requires stronger stimulus)
Stability	Lower (Prone to premature transition)	Higher (More robust Blue phase)

## References

- Wegner, G. (1969).[3] "Topochemical Polymerization of Monomers with Conjugated Triple Bonds." Z. Naturforsch. 24b, 824-831. (Foundational mechanism).[1]
- Baughman, R. H. (1974). "Solid-state synthesis of large polymer single crystals." Journal of Polymer Science: Polymer Physics Edition, 12(8), 1511-1535. [Link](#)
- Charych, D. H., et al. (1993).[3] "Direct colorimetric detection of a receptor-ligand interaction by a polymerized bilayer assembly." Science, 261(5121), 585-588. [Link](#)
- Okada, S., et al. (1998). "Polymerization of 5,7-dodecadiyne-1,12-diol derivatives." Molecular Crystals and Liquid Crystals.

- Spector, M. S., et al. (1998). "Rational design of chiral, tubule-forming diacetylenic lipids." *Langmuir*, 14(12), 3493-3500. [Link](#)

### Need Custom Synthesis?

BenchChem offers custom synthesis for rare earth carbides and specific isotopic labeling.

Email: [info@benchchem.com](mailto:info@benchchem.com) or [Request Quote Online](#).

## Sources

- 1. [polymercolloids.pusan.ac.kr](http://polymercolloids.pusan.ac.kr) [[polymercolloids.pusan.ac.kr](http://polymercolloids.pusan.ac.kr)]
- 2. [iris.uniroma1.it](http://iris.uniroma1.it) [[iris.uniroma1.it](http://iris.uniroma1.it)]
- 3. [escholarship.org](http://escholarship.org) [[escholarship.org](http://escholarship.org)]
- To cite this document: BenchChem. [Technical Guide: Mechanism of UV-Induced Polymerization of 5,7-Diynoic Lipids]. BenchChem, [2026]. [Online PDF]. Available at: [<https://www.benchchem.com/product/b1161692/docs#technical-guide-mechanism-of-uv-induced-polymerization-of-5-7-diynoic-lipids>]

### Disclaimer & Data Validity:

The information provided in this document is for Research Use Only (RUO) and is strictly not intended for diagnostic or therapeutic procedures. While BenchChem strives to provide accurate protocols, we make no warranties, express or implied, regarding the fitness of this product for every specific experimental setup.

**Technical Support:** The protocols provided are for reference purposes. Unsure if this reagent suits your experiment?

**Need Industrial/Bulk Grade?** [Request Custom Synthesis Quote](#)

# BenchChem

Our mission is to be the trusted global source of essential and advanced chemicals, empowering scientists and researchers to drive progress in science and industry.

## Contact

Address: 3281 E Guasti Rd

Ontario, CA 91761, United States

Phone: (601) 213-4426

Email: [info@benchchem.com](mailto:info@benchchem.com)

[Contact our Ph.D. Support Team for a compatibility check](#)