

# Solid-phase microextraction (SPME) methods for deuterated ethyl esters

**Author:** BenchChem Technical Support Team. **Date:** April 2026

## Compound of Interest

**Compound Name:** 2-Propylhexanoic Acid Ethyl Ester-  
d5

**Cat. No.:** B1161707

[Get Quote](#)

An In-Depth Technical Guide to Solid-Phase Microextraction (SPME) Methods for the Analysis of Deuterated Ethyl Esters

## Authored by: A Senior Application Scientist

### Introduction: The Analytical Imperative for Deuterated Ethyl Esters

In the landscape of modern analytical chemistry, particularly within pharmaceutical and metabolic research, deuterated compounds serve as indispensable tools. The substitution of hydrogen with its heavier, stable isotope, deuterium, creates molecules that are chemically similar to their parent compounds but physically distinguishable by mass spectrometry.<sup>[1]</sup> This unique property makes them ideal as internal standards for quantitative analysis, enabling precise correction for variations during sample preparation and analysis.<sup>[2][3][4]</sup> Deuteration can also intentionally alter metabolic pathways, slowing down drug metabolism to enhance pharmacokinetic profiles, a strategy of growing interest in drug development.<sup>[1][5][6][7]</sup>

Ethyl esters, a class of volatile organic compounds, are significant analytes in their own right. They are known as key aroma and flavor components in the food and beverage industry and can serve as important biomarkers in clinical diagnostics, such as fatty acid ethyl esters (FAEEs) which are markers for alcohol consumption.[8][9][10][11] The convergence of these two areas—the analytical utility of deuterated molecules and the biochemical relevance of ethyl esters—necessitates robust, sensitive, and efficient analytical methods.

Solid-Phase Microextraction (SPME) has emerged as a superior sample preparation technique for this purpose.[12][13] As a solvent-free method, SPME integrates sampling, extraction, and concentration into a single step, minimizing sample handling and the potential for analyte loss or contamination.[13][14][15] When coupled with Gas Chromatography-Mass Spectrometry (GC-MS), Headspace SPME (HS-SPME) provides a powerful platform for the analysis of volatile compounds like deuterated ethyl esters from complex matrices.[8] This application note provides a comprehensive guide to the principles, method development, and detailed protocols for the successful application of HS-SPME-GC-MS for the analysis of deuterated ethyl esters.

## The Principle of Headspace Solid-Phase Microextraction (HS-SPME)

HS-SPME is a non-exhaustive extraction technique based on the equilibrium partitioning of analytes between a sample matrix, the vapor phase (headspace) above the sample, and a stationary phase coated onto a fused silica fiber.[14][16] The process is governed by fundamental principles of thermodynamics and mass transfer.[12]

The core steps are:

- **Equilibration:** The sample is placed in a sealed vial and typically heated and agitated. This facilitates the migration of volatile analytes, such as ethyl esters, from the sample matrix into the headspace until an equilibrium is established.
- **Extraction (Adsorption/Absorption):** The SPME fiber is exposed to the headspace. Analytes in the vapor phase then partition onto the fiber's coating. The amount of analyte extracted by the fiber is proportional to its concentration in the headspace.[17]
- **Desorption:** The fiber is retracted and transferred to the heated injection port of a gas chromatograph. The high temperature causes the analytes to rapidly desorb from the fiber

and be swept onto the analytical column for separation and subsequent detection by a mass spectrometer.[8][18]

This approach is highly advantageous as it protects the fiber from non-volatile, high-molecular-weight components in the sample matrix, thereby extending fiber lifetime and improving analytical robustness.[12]

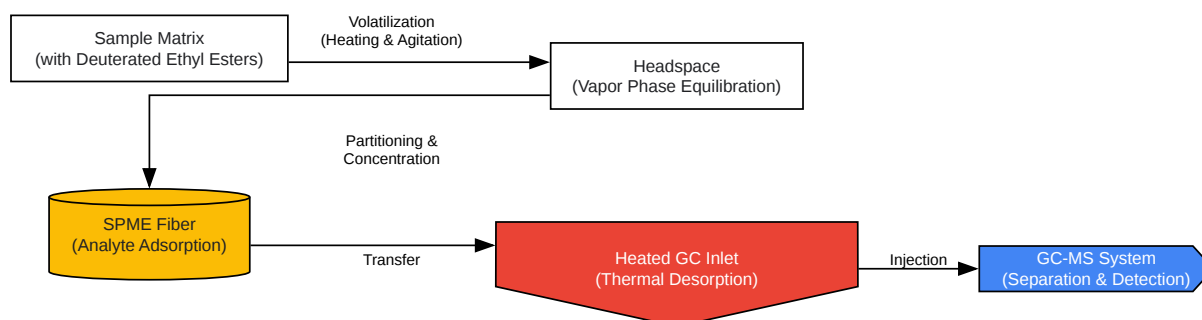

[Click to download full resolution via product page](#)

*Figure 1: Conceptual workflow of the HS-SPME process.*

## Method Development and Optimization: A Causality-Driven Approach

Optimizing an HS-SPME method is critical for achieving high sensitivity, accuracy, and reproducibility. Each parameter must be carefully selected based on the physicochemical properties of the target analytes—in this case, deuterated ethyl esters.

### SPME Fiber Selection: The Key to Efficient Extraction

The choice of SPME fiber coating is paramount as it dictates the extraction efficiency based on the analyte's polarity and volatility.[19] Ethyl esters are considered semi-polar compounds. For a broad range of volatile compounds, including esters, mixed-phase coatings are often recommended.[19]

Fiber Coating	Composition	Polarity	Primary Interaction	Suitability for Ethyl Esters
DVB/CAR/PDMS	Divinylbenzene/ Carboxen/Polydimethylsiloxane	Bipolar	Adsorption	Excellent. Recommended for broad-range C3-C20 volatile and semi-volatile compounds. High affinity for esters has been noted. <a href="#">[19]</a> <a href="#">[20]</a>
PDMS/DVB	Polydimethylsiloxane/Divinylbenzene	Bipolar	Absorption/Adsorption	Very Good. A general-purpose fiber effective for more volatile polar analytes like alcohols and esters. <a href="#">[16]</a> <a href="#">[19]</a>
Polyacrylate (PA)	Polyacrylate	Polar	Absorption	Good. Primarily for polar analytes. Can be effective but may be less efficient for less polar esters compared to mixed-phase fibers. <a href="#">[16]</a>
PDMS	Polydimethylsiloxane	Non-polar	Absorption	Fair. Best suited for non-polar, volatile compounds. May show lower efficiency for more polar ethyl esters. <a href="#">[20]</a>

Rationale: A Divinylbenzene/Carboxen/Polydimethylsiloxane (DVB/CAR/PDMS) fiber is often the optimal choice. The combination of different polymeric materials provides a range of interaction mechanisms (adsorption and absorption), allowing for the efficient trapping of a wide variety of analytes, including the semi-polar ethyl esters.[18][19]

## Sample Preparation: Managing the Matrix

The composition of the sample matrix significantly influences the partitioning of analytes into the headspace.[17]

- **Salting-Out Effect:** The addition of an inorganic salt, such as sodium chloride (NaCl), to aqueous samples is a common and highly effective strategy.[16] Adding salt increases the ionic strength of the solution, which decreases the solubility of organic analytes (the "salting-out" effect) and promotes their release into the headspace, thereby increasing extraction efficiency.[16][19][21] For many applications, adding 0.6 g of NaCl to a 2 mL sample is a good starting point.[19]
- **pH Adjustment:** The pH of the sample can influence the chemical form of certain analytes. For ethyl esters, which are generally stable under neutral conditions, pH adjustment is often unnecessary. However, if the matrix is highly acidic or basic, neutralization may be required to prevent hydrolysis of the ester bond.

## Extraction Parameters: The Equilibrium Triangle

The temperature and time used for incubation and extraction are codependent variables that must be optimized to ensure equilibrium is reached, leading to reproducible results.

- **Incubation/Extraction Temperature:** Higher temperatures increase the vapor pressure of the analytes, accelerating their transfer into the headspace and shortening the time needed to reach equilibrium. However, excessively high temperatures can negatively impact the partitioning of analytes from the headspace to the fiber. A typical starting range for volatile esters is 40°C to 60°C.[19][21]
- **Incubation Time:** This is the period during which the sample is heated and agitated before the SPME fiber is exposed. An adequate incubation time (e.g., 5-15 minutes) ensures that a stable equilibrium is established between the sample and the headspace.[19][21]

- **Extraction Time:** This is the duration the fiber is exposed to the headspace. The extraction is complete when the amount of analyte on the fiber reaches equilibrium. An insufficient extraction time will lead to poor sensitivity and reproducibility. Typical extraction times range from 20 to 45 minutes.[\[19\]](#)[\[22\]](#)

## The Critical Role of Deuterated Internal Standards

For accurate quantification, the use of a deuterated internal standard (IS) is the gold standard in mass spectrometry-based methods.[\[4\]](#)[\[23\]](#) An ideal IS is a deuterated analog of the target analyte (e.g., ethyl palmitate-d5 for the quantification of ethyl palmitate).[\[9\]](#)

Why it is essential:

- **Compensates for Variability:** The deuterated standard is added to the sample at a known concentration at the very beginning of the sample preparation process.[\[4\]](#) Because it is chemically almost identical to the analyte, it experiences the same potential losses during extraction, variations in injection volume, and matrix-induced signal suppression or enhancement in the ion source.[\[3\]](#)[\[23\]](#)
- **Improves Accuracy and Precision:** Quantification is based on the ratio of the peak area of the analyte to the peak area of the internal standard.[\[4\]](#) This ratio remains constant even if absolute signal intensities fluctuate, leading to highly accurate and precise results.
- **Co-elution:** The deuterated standard will have a nearly identical retention time to the non-deuterated analyte, ensuring that both compounds experience the same chromatographic conditions and matrix effects at the moment of detection.[\[3\]](#)

A potential, though often minimal, concern is the possibility of deuterium-hydrogen exchange, which can compromise results.[\[24\]](#) This is generally more of an issue for deuterium atoms attached to heteroatoms (like O or N) and is less common for those on a carbon backbone, as is typical for deuterated ethyl esters.

## Detailed Application Protocol: HS-SPME-GC-MS of Deuterated Ethyl Esters

This protocol provides a validated starting point for the analysis of fatty acid ethyl esters (FAEEs) and their deuterated analogs in a liquid matrix.

## Experimental Workflow Diagram

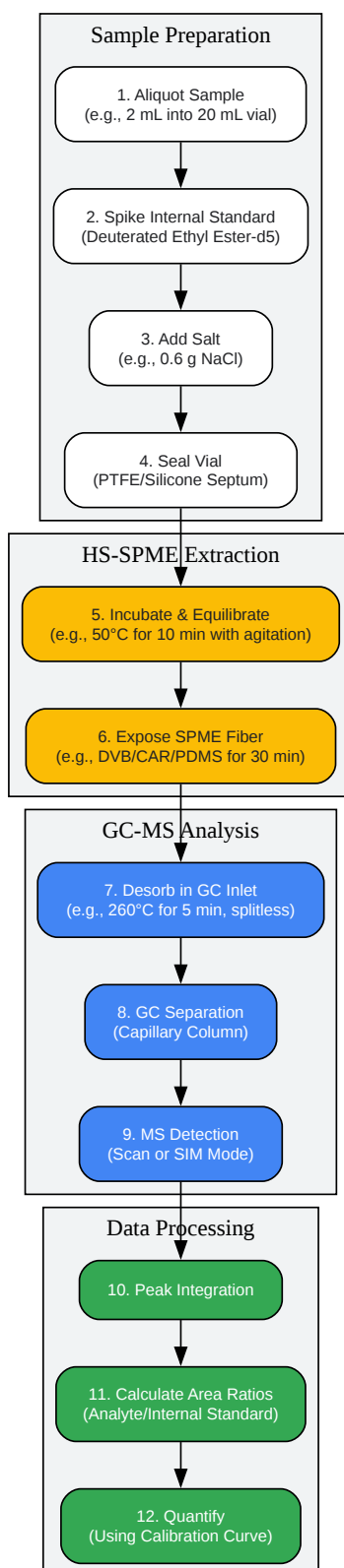

[Click to download full resolution via product page](#)

Figure 2: Step-by-step experimental workflow.

## Step-by-Step Methodology

- **Sample Preparation:** a. Pipette 2.0 mL of the liquid sample into a 20 mL headspace vial. b. Add a precise volume of the deuterated internal standard stock solution (e.g., ethyl palmitate-d5) to achieve a final concentration similar to the expected analyte concentration. c. Add 0.6 g of sodium chloride (NaCl) to the vial.[\[19\]](#) d. Immediately seal the vial with a PTFE/silicone septum and aluminum cap.
- **HS-SPME Extraction:** a. Place the vial in the autosampler tray of the GC-MS system equipped with an SPME autosampler. b. **Incubation:** Incubate the vial at 50°C for 10 minutes with agitation (e.g., 500 rpm) to allow for equilibration.[\[19\]](#) c. **Extraction:** Expose a pre-conditioned DVB/CAR/PDMS SPME fiber to the vial's headspace for 30 minutes at 50°C.[\[21\]](#)
- **GC-MS Analysis:** a. **Desorption:** After extraction, automatically retract the fiber and immediately insert it into the heated GC inlet, set to 260°C. Desorb for 5 minutes in splitless mode to ensure complete transfer of analytes.[\[11\]](#) b. **Separation and Detection:** Perform the analysis using the parameters outlined in the table below.

## Optimized HS-SPME-GC-MS Parameters

Parameter	Recommended Setting	Rationale
SPME Fiber	DVB/CAR/PDMS, 50/30µm	Broad selectivity for semi-polar volatile compounds.[18][19]
Incubation Temp.	50°C	Balances efficient volatilization with favorable headspace-fiber partitioning.[19]
Incubation Time	10 min	Ensures sample-headspace equilibrium is reached.[21]
Extraction Time	30 min	Allows for sufficient time to approach headspace-fiber equilibrium for reproducibility. [21]
GC Inlet Temp.	260°C	Ensures rapid and complete thermal desorption of esters from the fiber.[11]
Injection Mode	Splitless (for 5 min)	Maximizes the transfer of analytes to the column for trace-level analysis.
Carrier Gas	Helium, constant flow @ 1.0 mL/min	Inert gas providing good chromatographic efficiency.
GC Column	DB-5ms (or similar), 30 m x 0.25 mm, 0.25 µm	A robust, low-bleed, non-polar column suitable for a wide range of volatile and semi-volatile compounds.[21]
Oven Program	50°C (hold 2 min), ramp to 280°C @ 10°C/min, hold 5 min	Provides good separation of various ethyl esters.
MS Transfer Line	280°C	Prevents condensation of analytes.
Ion Source Temp.	230°C	Standard temperature for robust ionization.

---

MS Mode	Full Scan: (m/z 40-500) for method development and qualitative analysis. Selected Ion Monitoring (SIM): For quantitative analysis, monitoring specific ions for the analyte and the deuterated standard to maximize sensitivity.
---------	--

---

## Method Validation: Ensuring Trustworthiness and Reliability

A protocol is only as good as its validation. To ensure the method is fit for purpose, key performance characteristics must be evaluated.[8]

Validation Parameter	Description	Acceptance Criteria (Typical)
Linearity	The ability to elicit test results that are directly proportional to the analyte concentration. A calibration curve is constructed using at least 5 concentration levels.	Coefficient of determination ( $r^2$ ) > 0.995
Limit of Detection (LOD)	The lowest analyte concentration that can be reliably distinguished from background noise.	Signal-to-Noise Ratio (S/N) $\geq 3$
Limit of Quantification (LOQ)	The lowest analyte concentration that can be measured with acceptable precision and accuracy.	S/N $\geq 10$ ; Precision < 20% RSD
Precision (Repeatability)	The closeness of agreement between replicate measurements of the same sample. Assessed at low, medium, and high concentrations.	Relative Standard Deviation (RSD) < 15%
Accuracy (Recovery)	The closeness of the measured value to the true value. Assessed by analyzing spiked samples at known concentrations.	85-115% of the nominal value

The use of a deuterated internal standard is fundamental to achieving the stringent criteria required for precision and accuracy in a validated method.<sup>[3][23]</sup>

## Conclusion

The Headspace Solid-Phase Microextraction (HS-SPME) method coupled with GC-MS offers a robust, sensitive, and environmentally friendly approach for the quantitative analysis of deuterated ethyl esters.<sup>[8][21]</sup> By understanding the fundamental principles of SPME and systematically optimizing key parameters—from fiber selection to extraction conditions—researchers can develop highly reliable methods. The integration of deuterated internal standards is not merely a suggestion but a requirement for achieving the highest levels of accuracy and precision, compensating for the inherent variability of complex matrices and the analytical process itself.<sup>[2][3][23]</sup> This guide provides the foundational knowledge and a detailed protocol to empower researchers, scientists, and drug development professionals to successfully implement this powerful technique for their specific applications.

## References

- Benchchem. (n.d.). Application Note: Quantitative Analysis of Volatile Esters by Headspace Solid-Phase Microextraction Gas Chromatography-Mass Spectrometry (HS-SPME-GC-MS). Benchchem.
- Benchchem. (n.d.). Comparison of SPME fiber coatings for ethyl heptanoate extraction. Benchchem.
- Pragst, F., Auwärter, V., Sporkert, F., & Spiegel, K. (2001). Analysis of fatty acid ethyl esters in hair as possible markers of chronically elevated alcohol consumption by headspace solid-phase microextraction (HS-SPME) and gas chromatography-mass spectrometry (GC-MS). *Forensic Science International*, 121(1-2), 76-88. Retrieved from [\[Link\]](#)
- Unice, K. M., Kreider, M. L., & Panko, J. M. (2018). Use of a Deuterated Internal Standard with Pyrolysis-GC/MS Dimeric Marker Analysis to Quantify Tire Tread Particles in the Environment. *International Journal of Environmental Research and Public Health*, 15(9), 1836. Retrieved from [\[Link\]](#)
- Wardencki, W., Wasik, A., & Zygmunt, B. (2005). Determination of volatile fatty acid ethyl esters in raw spirits using solid phase microextraction and gas chromatography. *Journal of the Institute of Brewing*, 111(2), 169-175. Retrieved from [\[Link\]](#)
- Albermann, M. E., Musshoff, F., & Madea, B. (2009). Analysis of Fatty Acid Ethyl Esters in Hair by Headspace Solid-Phase Microextraction (HS-SPME) and Gas Chromatography-Mass Spectrometry (GC-MS). *Journal of the American Society for Mass Spectrometry*, 20(11), 2038-2044. Retrieved from [\[Link\]](#)

- Nikićević, N., Urošević, I., Tešević, V., Nedeljković, N., & Veličković, M. (2015). Determination of volatile fatty acid ethyl esters in raw spirits obtained from autochthonous plum cultivars using solid phase microextraction. *Journal of the Serbian Chemical Society*, 80(10), 1279-1288. Retrieved from [\[Link\]](#)
- de Oliveira, G. A. R., de Oliveira, A. P., de Souza, R. M., de Lima, G. P. G., & de Oliveira, L. A. (2018). Evaluation of Headspace Solid-Phase Microextraction Gas Chromatography–Mass Spectrometry for the Characterization of Volatile Organic Compounds of Melon Flowers. *Journal of the Brazilian Chemical Society*, 29(6), 1238-1246. Retrieved from [\[Link\]](#)
- Benchchem. (n.d.). Deuterated Internal Standard: Significance and symbolism. Benchchem.
- Anonymous. (n.d.). A REVIEW: USE OF DEUTERATED INTERNAL STANDARDS IN MASS SPECTROMETRY TECHNIQUES. ResearchGate.
- SCION Instruments. (2023, August 10). Internal Standards - What Are They? How Do I Choose, Use and Benefit From Them? SCION Instruments.
- Albermann, M. E., Musshoff, F., & Madea, B. (2014). A SPME-GC/MS Procedure for the Determination of Fatty Acid Ethyl Esters in Hair for Confirmation of Abstinence Test Results. *Journal of Chromatographic Science*, 52(9), 1017-1022. Retrieved from [\[Link\]](#)
- Ouyang, G., & Pawliszyn, J. (2008). A critical review in calibration methods for solid-phase microextraction. *Journal of Chromatography A*, 1206(2), 1-15. Retrieved from [\[Link\]](#)
- Lee, S. Y., et al. (2025). Optimized method for analyzing volatile compounds in edible yeast using headspace SPME-GC-MS. *Food Science and Biotechnology*. Retrieved from [\[Link\]](#)
- Landvatter, S. W., & Tyburski, R. (n.d.). Comparison of Deuterium, <sup>13</sup>C, and <sup>15</sup>N Isotopic Labels in Mass Spec Standards. Sigma-Aldrich.
- Li, C., et al. (2019). Headspace solid-phase microextraction (HS-SPME) coupled with gas chromatography-mass spectrometric (GC-MS) analysis of volatile profiles during the stir-frying process of malt. *Analytical Methods*, 11(36), 4633-4641. Retrieved from [\[Link\]](#)
- Oakes, K. D., et al. (2011). Validation and use of in vivo solid phase micro-extraction (SPME) for the detection of emerging contaminants in fish. *Chemosphere*, 85(7), 1166-1172. Retrieved from [\[Link\]](#)

- Mathure, S. V., et al. (2023). Development and validation of HS-SPME-GCMS/MS method for quantification of 2-acetyl-1-pyrroline in rice cultivars. *Journal of Food Science and Technology*, 60(2), 596-606. Retrieved from [\[Link\]](#)
- Souza-Silva, É. A., Gionfriddo, E., & Pawliszyn, J. (2015). Recent Developments and Applications of Solid Phase Microextraction (SPME) in Food and Environmental Analysis—A Review. *Molecules*, 20(7), 12284-12321. Retrieved from [\[Link\]](#)
- Benchchem. (n.d.). A Comparative Guide to the Validation of Headspace SPME-GC-MS for Propyl Octanoate Analysis. Benchchem.
- Jeleń, H. H., & Gracka, A. (2007). A novel SPME fibre for fatty acid determination. *Talanta*, 74(2), 202-208. Retrieved from [\[Link\]](#)
- Lee, J. E., et al. (2019). Comparison of headspace-SPME and SPME-Arrow-GC-MS methods for the determination of volatile compounds in Korean salt-fermented sand lance sauce (kanari-aekjeot). *Food Science and Biotechnology*, 28(6), 1735-1743. Retrieved from [\[Link\]](#)
- Ha, J., et al. (2019). Comparison of Different Types of SPME Arrow Sorbents to Analyze Volatile Compounds in *Cirsium setidens* Nakai. *Molecules*, 24(21), 3878. Retrieved from [\[Link\]](#)
- Merck Millipore. (n.d.). Selection Guide for Supelco SPME Fibers. Merck Millipore.
- Sajid, M., et al. (2024). Comparison of Different Solid-Phase Microextraction Formats Dedicated to the Analysis of Volatile Compounds—A Comprehensive Study. *Molecules*, 29(21), 5039. Retrieved from [\[Link\]](#)
- Clearsynth Discovery. (2025, May 20). Deuterated Drugs Future Potential. Clearsynth Discovery.
- Agilent. (n.d.). Solid Phase Microextraction Fundamentals. Agilent.
- Hinshaw, J. (2023, August 22). Solid-Phase Microextraction (SPME): A Discussion. LCGC International.
- Unibest Industrial Co., Ltd. (2024, July 31). 5 Benefits of Deuteration in Drug Discovery. Unibest Industrial Co., Ltd.

- Gioti, E. M., & Fiamegos, Y. C. (2022). Solid-Phase Microextraction Techniques and Application in Food and Horticultural Crops. *Horticulturae*, 8(2), 119. Retrieved from [[Link](#)]
- Ho, T. D., Canh, T. G., & Ho, C. T. (2015). Solid-phase microextraction technology for in vitro and in vivo metabolite analysis. *Journal of Food and Drug Analysis*, 23(3), 369-378. Retrieved from [[Link](#)]
- Li, Y., et al. (2025). Applications of Solid-Phase Microextraction and Related Techniques. *Molecules*, 30(4), 856. Retrieved from [[Link](#)]
- Biojiva. (2019, January 14). Applications of Deuterium in medicinal chemistry. Biojiva.
- Isowater® Corp. (n.d.). Science Research & Manufacturing Applications. Isowater® Corp.
- BOC Sciences. (n.d.). Benefits and Mechanisms of Deuterated Drugs | Enhanced Efficacy. BOC Sciences.

### Need Custom Synthesis?

BenchChem offers custom synthesis for rare earth carbides and specific isotopic labeling.

Email: [info@benchchem.com](mailto:info@benchchem.com) or [Request Quote Online](#).

## Sources

- [1. 5 Benefits of Deuteration in Drug Discovery - Unibest Industrial Co., Ltd. \[unibestpharm.com\]](#)
- [2. wisdomlib.org \[wisdomlib.org\]](#)
- [3. texilajournal.com \[texilajournal.com\]](#)
- [4. Internal Standardization In Chromatography Explained | Internal Std \[scioninstruments.com\]](#)
- [5. Benefits and Mechanisms of Deuterated Drugs | Enhanced Efficacy \[bocsci.com\]](#)
- [6. clearsynthdiscovery.com \[clearsynthdiscovery.com\]](#)
- [7. isowater.com \[isowater.com\]](#)
- [8. benchchem.com \[benchchem.com\]](#)
- [9. Analysis of fatty acid ethyl esters in hair as possible markers of chronically elevated alcohol consumption by headspace solid-phase microextraction \(HS-SPME\) and gas](#)

[chromatography-mass spectrometry \(GC-MS\) - PubMed \[pubmed.ncbi.nlm.nih.gov\]](#)

- [10. tandfonline.com \[tandfonline.com\]](#)
- [11. plum2020.institut-cacak.org \[plum2020.institut-cacak.org\]](#)
- [12. mdpi.com \[mdpi.com\]](#)
- [13. Applications of Solid-Phase Microextraction and Related Techniques | MDPI \[mdpi.com\]](#)
- [14. chromatographyonline.com \[chromatographyonline.com\]](#)
- [15. Solid-phase microextraction technology for in vitro and in vivo metabolite analysis - PMC \[pmc.ncbi.nlm.nih.gov\]](#)
- [16. agilent.com \[agilent.com\]](#)
- [17. researchgate.net \[researchgate.net\]](#)
- [18. Solid-Phase Microextraction Techniques and Application in Food and Horticultural Crops - PMC \[pmc.ncbi.nlm.nih.gov\]](#)
- [19. pdf.benchchem.com \[pdf.benchchem.com\]](#)
- [20. merckmillipore.com \[merckmillipore.com\]](#)
- [21. pdf.benchchem.com \[pdf.benchchem.com\]](#)
- [22. repositorio.unesp.br \[repositorio.unesp.br\]](#)
- [23. Use of a Deuterated Internal Standard with Pyrolysis-GC/MS Dimeric Marker Analysis to Quantify Tire Tread Particles in the Environment - PMC \[pmc.ncbi.nlm.nih.gov\]](#)
- [24. sigmaaldrich.com \[sigmaaldrich.com\]](#)
- To cite this document: BenchChem. [Solid-phase microextraction (SPME) methods for deuterated ethyl esters]. BenchChem, [2026]. [Online PDF]. Available at: [\[https://www.benchchem.com/product/b1161707/docs#solid-phase-microextraction-spme-methods-for-deuterated-ethyl-esters\]](https://www.benchchem.com/product/b1161707/docs#solid-phase-microextraction-spme-methods-for-deuterated-ethyl-esters)

---

### Disclaimer & Data Validity:

The information provided in this document is for Research Use Only (RUO) and is strictly not intended for diagnostic or therapeutic procedures. While BenchChem strives to provide accurate protocols, we make no warranties, express or implied, regarding the fitness of this product for every specific experimental setup.

**Technical Support:** The protocols provided are for reference purposes. Unsure if this reagent suits your experiment?

**Need Industrial/Bulk Grade?** [Request Custom Synthesis Quote](#)

## BenchChem

Our mission is to be the trusted global source of essential and advanced chemicals, empowering scientists and researchers to drive progress in science and industry.

### Contact

Address: 3281 E Guasti Rd  
Ontario, CA 91761, United States  
Phone: (601) 213-4426  
Email: [info@benchchem.com](mailto:info@benchchem.com)

[Contact our Ph.D. Support Team for a compatibility check](#)