

Comparative reactivity of acetyloxy vs. acetoxy functional groups

Author: BenchChem Technical Support Team. **Date:** April 2026

Compound of Interest

Compound Name: *(2-(2-Oxopropoxy)ethoxy)methyl Acetate*
Cat. No.: *B1161770*

[Get Quote](#)

A Comparative Analysis of Acetyloxy and Acetoxy Group Reactivity

A deep dive into the electronic and steric effects governing the reactivity of acetyloxy and acetoxy functional groups, with practical insights for synthetic strategy and drug development.

In the landscape of organic chemistry, the nuanced differences between functional groups can dramatically influence molecular reactivity and, consequently, their application in synthesis and medicine. This guide provides a comparative analysis of the acetyloxy and acetoxy groups, two ester functionalities with distinct reactivity profiles. We will explore their electronic and steric characteristics, leaving group abilities, and participation in neighboring group effects, supported by experimental data and established protocols.

Unveiling the Contestants: Acetyloxy vs. Acetoxy

At first glance, the acetyloxy ($-\text{OCH}_2\text{C}(\text{O})\text{CH}_3$) and acetoxy ($-\text{OC}(\text{O})\text{CH}_3$) groups appear structurally similar. Both are esters of acetic acid, but the seemingly minor insertion of a

methylene spacer in the acetyloxy group fundamentally alters its electronic properties and steric profile, leading to significant differences in reactivity.

Functional Group	Structure	Key Features
Acetyloxy	$-\text{OCH}_2\text{C}(\text{O})\text{CH}_3$	Methylene spacer isolates the carbonyl group from the oxygen atom.
Acetoxy	$-\text{OC}(\text{O})\text{CH}_3$	Carbonyl group is directly attached to the oxygen atom. [1] [2] [3]

Reactivity Showdown: A Head-to-Head Comparison

The reactivity of these two groups can be assessed across several key chemical transformations, including their propensity to act as leaving groups and their susceptibility to hydrolysis.

Leaving Group Ability: A Tale of Two Stabilities

A good leaving group is one that can stabilize the negative charge it acquires upon departure. [\[4\]](#)[\[5\]](#) In this regard, the acetoxy group is generally considered a better leaving group than the acetyloxy group.

The stability of the resulting carboxylate anion from the acetoxy group is enhanced by resonance, delocalizing the negative charge between the two oxygen atoms. [\[6\]](#) The acetyloxy group, upon departure, would form an alkoxide, which is a less stable, more basic species.

However, the context of the reaction is crucial. In certain scenarios, particularly those involving neighboring group participation, the reactivity can be significantly altered.

Hydrolysis: The Impact of Electronic Effects

The hydrolysis of esters, the cleavage of the ester bond by water, can be catalyzed by either acid or base. [\[7\]](#)[\[8\]](#)[\[9\]](#)[\[10\]](#) The rate of hydrolysis is influenced by the electronic nature of the carbonyl carbon.

The carbonyl carbon in the acetoxy group is directly attached to a highly electronegative oxygen atom, which inductively withdraws electron density, making the carbonyl carbon more electrophilic and susceptible to nucleophilic attack by water. In the acetoxyloxy group, the methylene spacer mitigates this inductive effect, rendering the carbonyl carbon less electrophilic and the ester less prone to hydrolysis under similar conditions.

The Power of Proximity: Neighboring Group Participation

Neighboring group participation (NGP) can significantly accelerate reaction rates and influence stereochemical outcomes.^{[11][12]} The acetoxy group, when positioned appropriately within a molecule, can act as an internal nucleophile, leading to the formation of a cyclic intermediate.^{[13][14]}

A classic example is the anchimeric assistance provided by a C-2 acetoxy group in the substitution reactions of pyran-derived acetals.^{[13][14]} The acetoxy group can form a stabilized cis-fused dioxolenium ion, which is then opened by an external nucleophile to yield a 1,2-trans product with high stereoselectivity.^[13] The extent of this participation is influenced by the electron-donating ability of the acyl group; less electron-donating groups lead to higher 1,2-trans selectivity.^{[13][14][15]}

The acetoxyloxy group, due to the flexibility of the methylene spacer, is less likely to engage in this type of rigid, five-membered ring formation, and therefore, its participation in NGP is generally less pronounced.

Synthetic Applications and Strategic Considerations

The distinct reactivity profiles of acetoxyloxy and acetoxy groups have important implications for their use in organic synthesis.

- **Protecting Groups:** The acetoxy group is commonly used as a protecting group for alcohols.^{[1][3]} Its introduction is typically achieved through acetylation with reagents like acetic anhydride or acetyl chloride.^{[1][3][6]} Deprotection can be accomplished under acidic or basic conditions.^{[1][3]} The relative stability of the acetoxyloxy group to hydrolysis might make it a more robust protecting group in certain contexts.

- α -Functionalization of Ketones: α -Acetoxy and α -acetoxyloxy ketones are valuable synthetic intermediates.[16] Various methods have been developed for their synthesis, including gold-catalyzed intermolecular oxidation of terminal alkynes and thallium(III)-promoted α -oxidation of ketones.[16][17]

Experimental Protocols

Protocol 1: Synthesis of α -Acetoxy Ketones via Gold-Catalyzed Intermolecular Oxidation

This protocol is adapted from the work of Wu et al. and provides a method for the synthesis of α -acetoxy ketones from terminal alkynes.[16]

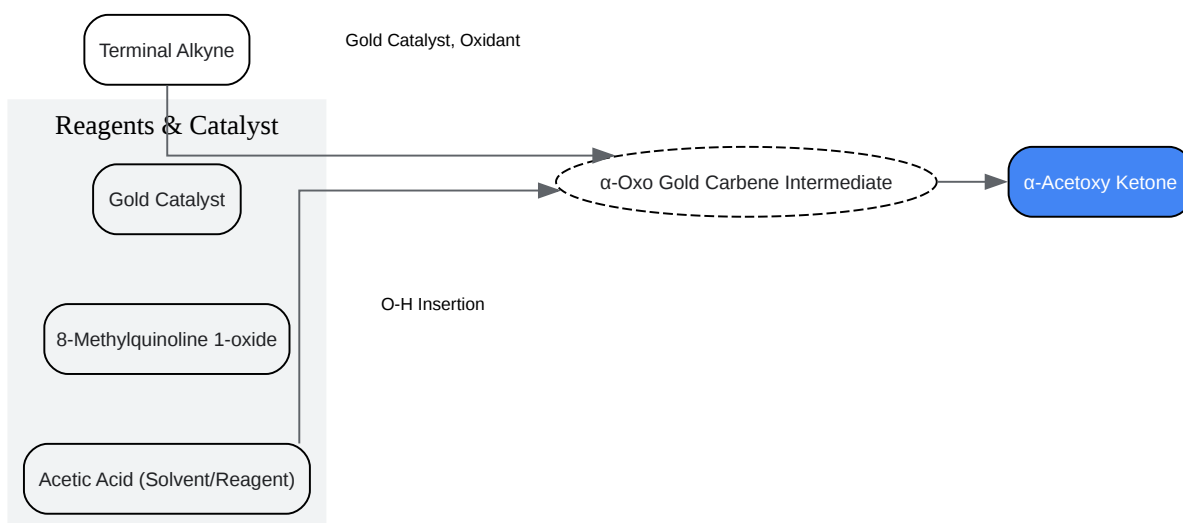

[Click to download full resolution via product page](#)

Caption: Gold-catalyzed synthesis of α -acetoxy ketones.

Materials:

- Terminal alkyne

- Gold catalyst (e.g., AuCl₃)
- 8-Methylquinoline 1-oxide (oxidant)
- Acetic acid (solvent and reagent)
- Inert solvent (e.g., Dichloromethane)

Procedure:

- In a round-bottom flask, dissolve the terminal alkyne in acetic acid.
- Add the gold catalyst and 8-methylquinoline 1-oxide to the solution.
- Stir the reaction mixture at the appropriate temperature (e.g., 60 °C) under an inert atmosphere.
- Monitor the reaction progress by thin-layer chromatography (TLC).
- Upon completion, quench the reaction and perform an aqueous workup.
- Purify the crude product by column chromatography to obtain the desired α -acetoxy ketone.

Protocol 2: Hydrolysis of an Acetoxy Ester

This protocol outlines the general procedure for the base-catalyzed hydrolysis (saponification) of an ester.^{[7][9][10]}

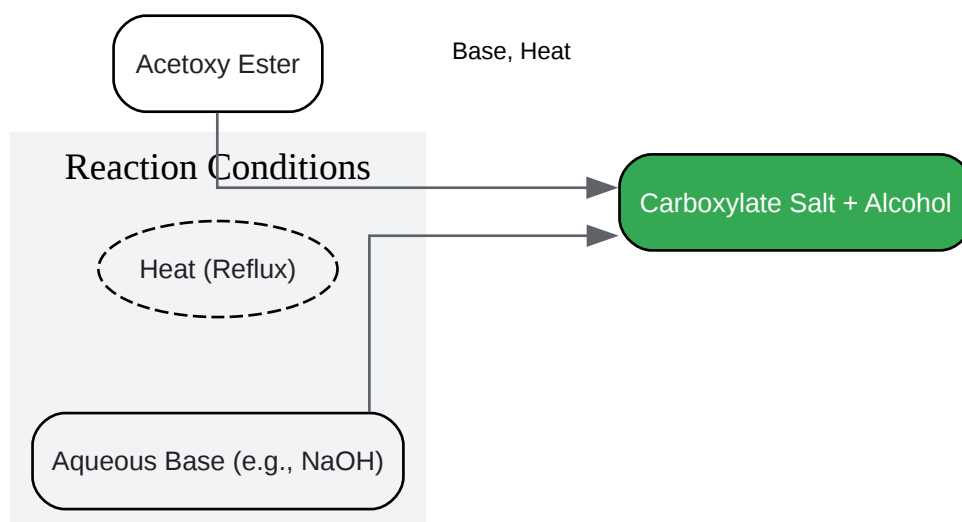

[Click to download full resolution via product page](#)

Caption: Base-catalyzed hydrolysis of an acetoxy ester.

Materials:

- Acetoxy-containing compound
- Aqueous base solution (e.g., 1 M Sodium Hydroxide)
- Ethanol (co-solvent, if needed)
- Reflux apparatus

Procedure:

- Dissolve the acetoxy-containing compound in ethanol in a round-bottom flask.
- Add the aqueous base solution to the flask.
- Heat the mixture to reflux and maintain for the required reaction time.
- Monitor the reaction by TLC to confirm the disappearance of the starting material.
- After completion, cool the reaction mixture to room temperature.

- Acidify the mixture with a suitable acid (e.g., HCl) to protonate the carboxylate salt.
- Extract the product with an appropriate organic solvent.
- Dry the organic layer, concentrate it, and purify the product as necessary.

Conclusion

While both acetoxy and acetoxy groups are ester functionalities, their reactivity profiles are distinct due to subtle but significant structural differences. The direct attachment of the carbonyl group to the oxygen in the acetoxy group enhances its electrophilicity and leaving group ability, while also enabling its participation in neighboring group effects. The methylene spacer in the acetoxy group tempers these electronic effects, leading to a generally less reactive functional group. A thorough understanding of these differences is paramount for researchers and drug development professionals in designing synthetic routes and predicting the chemical behavior of complex molecules.

References

Need Custom Synthesis?

BenchChem offers custom synthesis for rare earth carbides and specific isotopic labeling.

Email: info@benchchem.com or [Request Quote Online](#).

Sources

- [1. Acetoxy group - Wikipedia \[en.wikipedia.org\]](#)
- [2. grokipedia.com \[grokipedia.com\]](#)
- [3. Chemistry:Acetoxy group - HandWiki \[handwiki.org\]](#)
- [4. Leaving group - Wikipedia \[en.wikipedia.org\]](#)
- [5. youtube.com \[youtube.com\]](#)
- [6. Acetyl group - Wikipedia \[en.wikipedia.org\]](#)
- [7. 15.9 Hydrolysis of Esters | The Basics of General, Organic, and Biological Chemistry \[courses.lumenlearning.com\]](#)

- 8. 25.6 Reactions of Esters – Organic and Biochemistry Supplement to Enhanced Introductory College Chemistry [ecampusontario.pressbooks.pub]
- 9. chemguide.co.uk [chemguide.co.uk]
- 10. chem.libretexts.org [chem.libretexts.org]
- 11. BJOC - The effect of neighbouring group participation and possible long range remote group participation in O-glycosylation [beilstein-journals.org]
- 12. m.youtube.com [m.youtube.com]
- 13. Neighboring-group Participation by C-2 Acyloxy Groups: Influence of the Nucleophile and Acyl Group on the Stereochemical Outcome of Acetal Substitution Reactions - PMC [pmc.ncbi.nlm.nih.gov]
- 14. Neighboring-Group Participation by C-2 Acyloxy Groups: Influence of the Nucleophile and Acyl Group on the Stereochemical Outcome of Acetal Substitution Reactions - PubMed [pubmed.ncbi.nlm.nih.gov]
- 15. researchgate.net [researchgate.net]
- 16. organic-chemistry.org [organic-chemistry.org]
- 17. Synthesis of α -acetoxy and formyloxy ketones by thallium(iii) promoted α -oxidation - Chemical Communications (RSC Publishing) [pubs.rsc.org]
- To cite this document: BenchChem. [Comparative reactivity of acetyloxy vs. acetoxy functional groups]. BenchChem, [2026]. [Online PDF]. Available at: [https://www.benchchem.com/product/b1161770/docs#comparative-reactivity-of-acetyloxy-vs-acetoxy-functional-groups]

Disclaimer & Data Validity:

The information provided in this document is for Research Use Only (RUO) and is strictly not intended for diagnostic or therapeutic procedures. While BenchChem strives to provide accurate protocols, we make no warranties, express or implied, regarding the fitness of this product for every specific experimental setup.

Technical Support: The protocols provided are for reference purposes. Unsure if this reagent suits your experiment?

Need Industrial/Bulk Grade? [Request Custom Synthesis Quote](#)

BenchChem

Our mission is to be the trusted global source of essential and advanced chemicals, empowering scientists and researchers to drive progress in science and industry.

Contact

Address: 3281 E Guasti Rd

Ontario, CA 91761, United States

Phone: (601) 213-4426

Email: info@benchchem.com

[Contact our Ph.D. Support Team for a compatibility check](#)