

Technical Support Center: L-Thyronine (T3) LC-MS/MS Analysis

Author: BenchChem Technical Support Team. **Date:** May 2026

Compound of Interest

Compound Name: *L-Thyronine-13C6*

Cat. No.: *B1160030*

[Get Quote](#)

Status: Operational | Tier: Advanced Application Support

Introduction: The T3 Paradox

L-Thyronine (T3) presents a unique "perfect storm" for LC-MS/MS analysis:

- **Amphoteric Polarity:** It contains both acidic (carboxylic, phenolic) and basic (amine) groups, making extraction efficiency pH-dependent.
- **Isomeric Interference:** It shares an exact mass (651.9) with Reverse T3 (rT3), requiring chromatographic baseline resolution.
- **Endogenous Presence:** There is no true "blank" human matrix, complicating calibration.

This guide provides the protocols and troubleshooting logic to minimize matrix effects and ensure data integrity.

Module 1: Sample Preparation (The First Line of Defense)

The Problem: Protein Precipitation (PPT) is insufficient. While PPT removes proteins, it leaves >90% of phospholipids (glycerophosphocholines) in the supernatant. These phospholipids co-elute with T3, causing massive ion suppression in the electrospray droplet.

The Solution: Mixed-Mode Strong Anion Exchange (MAX) or Polymer-based SPE. Because T3 is zwitterionic, we exploit its pKa values (COOH ~2.4, NH₂ ~8.5, Phenol ~8.5).

Protocol: Phospholipid-Free T3 Extraction (MAX-SPE)

This protocol utilizes a Mixed-Mode Anion Exchange mechanism to lock T3 onto the sorbent while washing away neutral lipids and zwitterionic phospholipids.

Step	Reagent/Condition	Mechanistic Rationale
1. Pre-treatment	200 μ L Serum + 10 μ L IS + 200 μ L 4% H ₃ PO ₄	Acidification (pH < 2) protonates the T3 amine (NH ₃ ⁺) and keeps the carboxylic acid neutral, preparing it for hydrophobic retention.
2. Conditioning	1 mL MeOH, then 1 mL Water	Activates the polymeric sorbent pores.
3. Loading	Load pre-treated sample (Low flow: 1 mL/min)	T3 binds via Hydrophobic interaction (Reverse Phase mode).
4. Wash 1	1 mL 50 mM Ammonium Acetate (pH 7)	Neutralizes the carboxylic acid. Removes salts and proteins.
5. Wash 2	1 mL Methanol	CRITICAL STEP: Removes hydrophobic interferences (neutral lipids) and phospholipids. T3 remains bound via Anion Exchange (interaction between deprotonated T3 carboxylate and sorbent amine).
6. Elution	2 x 200 μ L 5% Formic Acid in Methanol	Acidification breaks the ionic bond; high organic solvent releases the hydrophobic bond.
7. Dry Down	N ₂ at 40°C	Remove solvent. Reconstitute in 20% MeOH/Water.



Tech Note: Do not use 100% aqueous reconstitution. T3 has poor solubility in pure water and may adsorb to glass/plastic vials. Use at least 20% organic solvent.

Module 2: Chromatographic Resolution (Isomer Management)

The Problem: T3 and rT3 are isobaric. Standard C18 columns often fail to separate them adequately. If rT3 co-elutes, it will contribute to the T3 MRM signal, causing false positives.

The Solution: Phenyl-Hexyl or Biphenyl Stationary Phases. These phases utilize

interactions with the iodine atoms on the thyronine rings, offering superior selectivity for isomers compared to hydrophobic C18 interactions.

Recommended LC Parameters

- Column: Biphenyl or Phenyl-Hexyl (2.1 x 50mm, 1.7 μ m or 2.6 μ m).
- Mobile Phase A: Water + 0.1% Formic Acid.[\[1\]](#)[\[2\]](#)
- Mobile Phase B: Methanol + 0.1% Formic Acid.[\[1\]](#)[\[2\]](#)
 - Note: Methanol is preferred over Acetonitrile for T3 because it enhances the selectivity mechanism.
- Gradient: Start at 30% B. Ramp to 90% B over 5 minutes.

Visualizing the Separation Logic

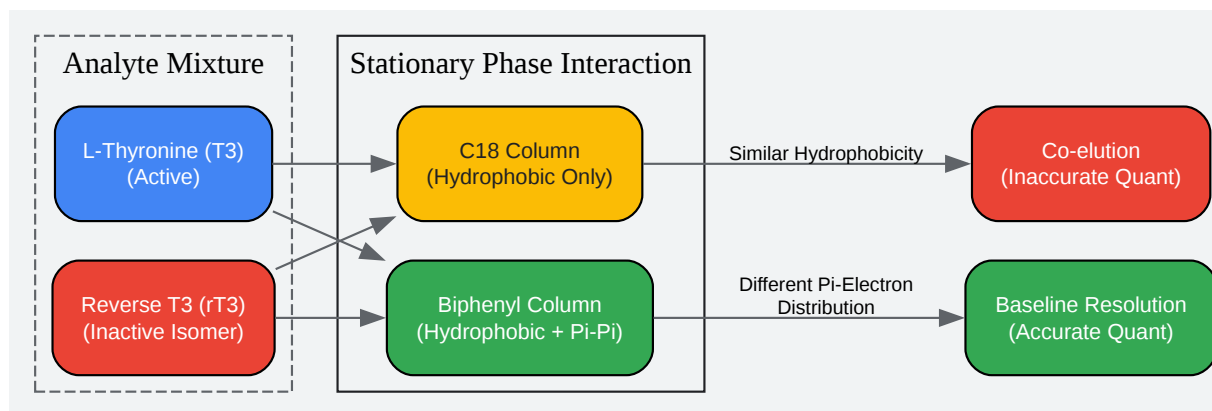

[Click to download full resolution via product page](#)

Figure 1: Mechanism of chromatographic selectivity. Biphenyl phases exploit the positional differences of iodine atoms (electron-withdrawing) to separate T3 from rT3.

Module 3: Calibration & Background Correction

The Problem: There is no T3-free human serum. Using "Charcoal Stripped Serum" (CSS) is common but risky. Stripping removes not just T3, but also peptides, growth factors, and lipids that constitute the "matrix." Therefore, CSS does not truly mimic patient samples, leading to differential matrix effects.

The Solution: Surrogate Matrix Validation or Surrogate Analyte.

Strategy A: Surrogate Matrix (PBS/BSA)

Use 4% Bovine Serum Albumin (BSA) in Phosphate Buffered Saline (PBS).

- Validation Requirement: You must perform a "Parallelism" experiment.
- Test: Spike IS into BSA and into pooled patient serum. Compare the peak area response. If the Matrix Factor (MF) difference is <15%, the surrogate is valid.

Strategy B: Surrogate Analyte (The "Gold Standard")

Use ¹³C-labeled T3 as the calibrator and measure it against the native T3 in the sample. This is expensive but eliminates matrix matching issues entirely.

Module 4: Troubleshooting & FAQs

Q1: My Internal Standard (T3-d6) signal is suppressing by 50% in patient samples compared to solvent standards. Why?

A: This is classic Ion Suppression.

- Mechanism: Phospholipids eluting at the same time as T3 are competing for charge on the surface of the electrospray droplet.
- Fix:
 - Check your retention time. If T3 elutes in the "void volume" or early gradient, it is co-eluting with salts. Retain T3 longer.
 - Switch from PPT to the MAX-SPE protocol (Module 1).
 - Diverter Valve: Divert the first 1.5 minutes of LC flow to waste to prevent salts from fouling the source.

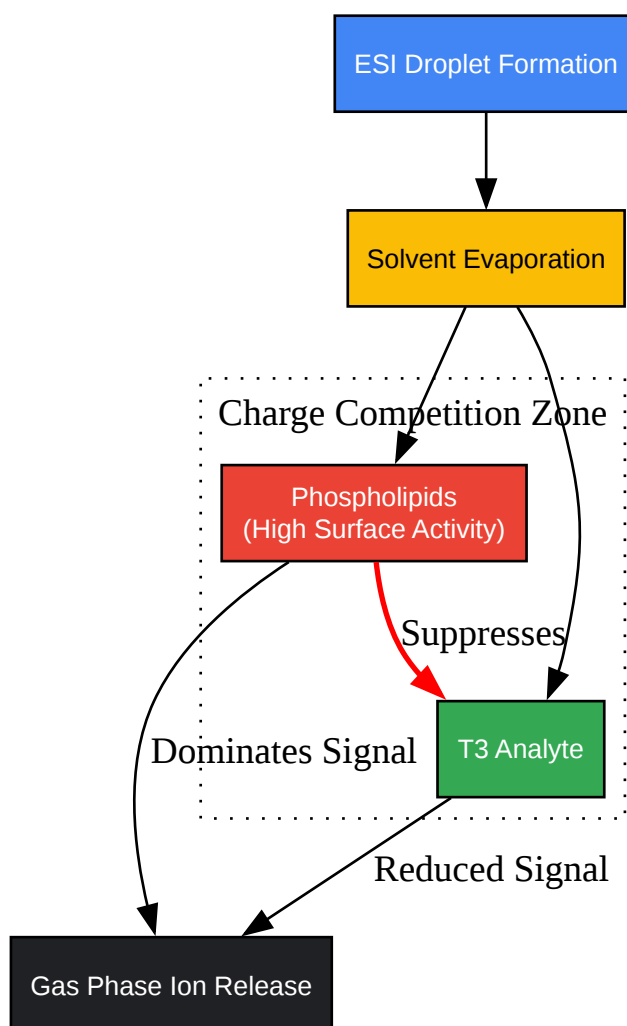

[Click to download full resolution via product page](#)

Figure 2: The mechanics of Ion Suppression in ESI. Phospholipids monopolize the droplet surface, preventing T3 from entering the gas phase.

Q2: I see a small peak for T3 in my double blank (no analyte, no IS). Is it carryover?

A: Likely, but check the T4 to T3 conversion.

- Cause: If your system has T4 contamination (or if T4 is in the sample), in-source fragmentation can strip an iodine atom from T4 (

777), creating a pseudo-T3 signal (

651).

- Test: Inject a high concentration T4 standard. Monitor the T3 transition. If you see a peak, you have in-source conversion.
- Fix: Lower the Desolvation Temperature or Cone Voltage.

Q3: Should I use Positive or Negative ESI mode?

A: Positive Mode (ESI+). While T3 has acidic moieties, it protonates readily on the amine group. ESI+ generally offers 5-10x better sensitivity (LOD ~1-2 pg/mL) compared to Negative mode, which is crucial for measuring free T3 levels.

References

- Centers for Disease Control and Prevention (CDC). Laboratory Procedure Manual: Thyroid Stimulating Hormone and Thyroid Hormones. [Link](#)
- Tai, S. S., et al. (2011). "Development and Evaluation of a Reference Measurement Procedure for the Determination of Total 3,3',5-Triiodothyronine in Human Serum Using Isotope-Dilution Liquid Chromatography-Tandem Mass Spectrometry." Analytical Chemistry. [Link](#)
- Biotage. "Extraction of thyroid hormones T3, rT3 and T4 from serum using EVOLUTE® EXPRESS AX." Application Note. [Link](#)
- Sigma-Aldrich (Merck). "Online Solid Phase Extraction and LC/MS/MS Detection of Thyroid Hormones in Biological Fluids." Reporter US. [Link](#)
- Waters Corporation. "LC-MS/MS Method for the Analysis of Thyroid Hormones in Human Serum." Application Note. [Link](#)

Need Custom Synthesis?

BenchChem offers custom synthesis for rare earth carbides and specific isotopic labeling.

Email: info@benchchem.com or [Request Quote Online](#).

Sources

- [1. biotage.com](https://www.biotage.com) [biotage.com]
- [2. mac-mod.com](https://www.mac-mod.com) [mac-mod.com]
- To cite this document: BenchChem. [Technical Support Center: L-Thyronine (T3) LC-MS/MS Analysis]. BenchChem, [2026]. [Online PDF]. Available at: [<https://www.benchchem.com/product/b1160030/docs#technical-support-center-l-thyronine-t3-lc-ms-ms-analysis>]

Disclaimer & Data Validity:

The information provided in this document is for Research Use Only (RUO) and is strictly not intended for diagnostic or therapeutic procedures. While BenchChem strives to provide accurate protocols, we make no warranties, express or implied, regarding the fitness of this product for every specific experimental setup.

Technical Support: The protocols provided are for reference purposes. Unsure if this reagent suits your experiment?

Need Industrial/Bulk Grade? [Request Custom Synthesis Quote](#)

BenchChem

Our mission is to be the trusted global source of essential and advanced chemicals, empowering scientists and researchers to drive progress in science and industry.

Contact

Address: 3281 E Guasti Rd
Ontario, CA 91761, United States
Phone: (601) 213-4426
Email: info@benchchem.com

[Contact our Ph.D. Support Team for a compatibility check](#)

