

Advanced Pharmacokinetic Profile Modeling Using 5-Azacytidine-13C4 Tracers

Author: BenchChem Technical Support Team. **Date:** May 2026

Compound of Interest

Compound Name: 5-Azacytidine-13C4

Cat. No.: B1160423

[Get Quote](#)

Executive Summary

This technical guide details the methodology for modeling the pharmacokinetic (PK) profile of 5-Azacytidine (Azacitidine) using a 13C4 stable isotope tracer. 5-Azacytidine presents unique bioanalytical challenges due to its rapid aqueous hydrolysis and metabolic susceptibility to cytidine deaminase (CDA). Furthermore, its mass similarity to endogenous cytidine (1 Da difference) complicates mass spectrometric quantification due to isotopic envelope overlap.

The use of a **5-Azacytidine-13C4** tracer (typically labeled on the ribose or triazine ring) provides a +4 Da mass shift, effectively resolving it from endogenous interference. This guide outlines a self-validating workflow—from sample stabilization to compartmental modeling—enabling researchers to quantify metabolic flux, distinguish hydrolysis from enzymatic deamination, and accurately model the drug's disposition in vivo.

Part 1: The Bioanalytical Challenge

Chemical Instability and Metabolism

5-Azacytidine is a cytidine analogue where the carbon at position 5 of the pyrimidine ring is replaced by nitrogen. This modification renders the 1,3,5-triazine ring highly unstable in

aqueous environments.

- **Hydrolysis:** The triazine ring undergoes rapid, reversible opening to form N-formylguanylrribosylurea (RGU-CHO), which subsequently decomposes irreversibly to guanylrribosylurea (RGU). This process is pH- and temperature-dependent.
- **Enzymatic Deamination:** Cytidine Deaminase (CDA) rapidly converts 5-Azacytidine to 5-Aza-Uridine, an inactive metabolite.

The Mass Spectrometry Interference Problem

In Liquid Chromatography-Tandem Mass Spectrometry (LC-MS/MS), 5-Azacytidine (

, MW ~244.2) and endogenous Cytidine (

, MW ~243.2) are separated by only ~1 Da.[1]

- **The Issue:** The naturally occurring M+1 isotope of Cytidine (containing ¹³C or ¹⁵N) has a mass of ~244.2, which is isobaric with the monoisotopic mass of 5-Azacytidine. In biological matrices with high endogenous cytidine, this creates a significant background signal that compromises the Lower Limit of Quantitation (LLOQ).
- **The Solution:** A ¹³C₄ tracer shifts the precursor mass to ~248.2 Da. This +4 Da shift moves the analyte signal well beyond the isotopic envelope of endogenous cytidine, ensuring high specificity.

Part 2: Experimental Design & Methodology

Tracer Selection and Standards

To model the PK profile accurately, the tracer must track the active pharmaceutical ingredient (API) without metabolic loss of the label prior to the rate-limiting step.

- **Recommended Tracer:** 5-Azacytidine-[Ribose-¹³C₄] or 5-Azacytidine-[Triazine-¹³C₃, ¹⁵N₁].
 - **Rationale:** A +4 Da shift is sufficient to avoid cross-talk. Ribose labeling is advantageous for tracking the nucleoside distribution, while ring labeling confirms the integrity of the

pharmacophore.

- Internal Standard (IS): Use a distinct isotopologue, such as 5-Azacytidine-15N4, to correct for extraction efficiency and matrix effects. Do not use the 13C4 tracer as the IS if it is being administered as the study drug.

Sample Collection and Stabilization Protocol (Critical)

The validity of the PK model depends entirely on arresting hydrolysis and deamination at the moment of collection.

Step-by-Step Stabilization Protocol:

- Preparation: Pre-chill collection tubes containing Tetrahydrouridine (THU) (final conc. 25 µg/mL) to inhibit CDA.
- Collection: Draw blood and immediately invert to mix with THU.
- Plasma Separation: Centrifuge at 4°C (2000 x g, 10 min) immediately.
- Acidification: Transfer plasma to cryovials containing 1% Formic Acid or Citric Acid (to lower pH to ~6.0–6.5, where 5-Azacytidine is most stable).
- Storage: Snap freeze in liquid nitrogen and store at -80°C. Note: Analysis should be performed within 4 weeks.

LC-MS/MS Quantification Workflow

Parameter	Specification
Column	HILIC (Hydrophilic Interaction Liquid Chromatography) or C18 with Ion Pairing. Recommended: Amide-HILIC (2.1 x 100 mm, 1.7 μ m).
Mobile Phase A	10 mM Ammonium Acetate + 0.1% Formic Acid in Water (pH 3.5)
Mobile Phase B	Acetonitrile + 0.1% Formic Acid
Gradient	90% B to 50% B over 5 minutes (Retains polar nucleosides).
Ionization	ESI Positive Mode
MRM Transitions	Analyte (13C4): 248.2 117.1 (Ribose-13C4 fragment) Endogenous Cytidine: 244.2 112.1 Internal Standard (15N4): 248.2 117.1 (Check for cross-talk) or 248.2 113.1

Expert Insight: If using Ribose-13C4, the fragment ion (sugar) will carry the label. If using Ring-13C4, the fragment ion (base) will carry the label. Ensure your MRM transitions match your specific tracer structure.

Part 3: Pharmacokinetic Modeling Framework

Compartmental Model Structure

Because 5-Azacytidine is rapidly eliminated and distributed, a Two-Compartment Model with First-Order Elimination is typically required. However, the model must explicitly account for hydrolytic degradation (

) as a parallel elimination pathway distinct from metabolic clearance (

).

Model Parameters:

- : Volume of distribution (Central compartment).
 - : Inter-compartmental rate constants.
 - : Total elimination rate constant (
-).

Visualizing the Metabolic Flux

The following diagram illustrates the kinetic pathways of **5-Azacytidine-13C4**. The tracer allows us to quantify the flux into the "Active" DNA/RNA compartments versus the "Waste" hydrolysis/deamination pathways.

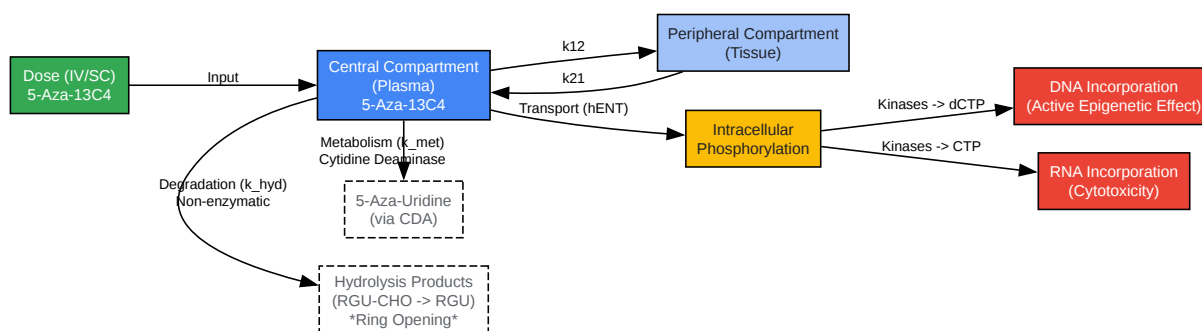

[Click to download full resolution via product page](#)

Caption: Kinetic pathway of **5-Azacytidine-13C4**. The tracer distinguishes intact drug (Central) from metabolites. Note that hydrolysis is non-enzymatic and occurs in all aqueous compartments.

Mathematical Formulation

To solve for the concentration of 5-Azacytidine (

) at time

:

Where

and

are hybrid rate constants derived from the micro-constants. Crucially, when using the $^{13}\text{C}_4$ tracer, you can calculate the Hydrolysis Index (

):

Note: Measuring RGU (Guanylribosylurea) requires a specific MRM transition for the hydrolyzed $^{13}\text{C}_4$ -labeled product. If the label is on the ribose, RGU- $^{13}\text{C}_4$ is detectable.

Part 4: Data Interpretation & Quality Control

Interpreting the Tracer Signal

- Intact 5-Aza- $^{13}\text{C}_4$: Represents the bioavailable fraction capable of pharmacological activity.
- Loss of Signal: Due to the instability, "Total Radioactivity" (in ^{14}C studies) often overestimates exposure. The $^{13}\text{C}_4$ LC-MS/MS method specifically measures the intact ring structure (assuming the MRM targets the parent-to-base or parent-to-sugar transition effectively).
- Differentiating Pathways:
 - If the $^{13}\text{C}_4$ label is on the Ribose: You can track the nucleoside into RNA/DNA and the hydrolysis product (RGU).
 - If the $^{13}\text{C}_4$ label is on the Triazine Ring: You can track the active drug and deaminated 5-Aza-Uridine, but ring opening (hydrolysis) may disrupt the mass shift pattern depending on the fragmentation.

Common Pitfalls

- Ex Vivo Degradation: Failure to acidify and add THU immediately will result in an artificially low

and AUC, and an overestimation of clearance (

).

- Ion Suppression: HILIC methods are susceptible to matrix effects from salts. Use the $^{15}\text{N}_4$ Internal Standard to normalize.
- Isotope Scrambling: While rare for ^{13}C , ensure the label position is biologically stable (e.g., not at a metabolic cleavage site like the glycosidic bond, though 5-Aza is resistant to phosphorylase cleavage).

References

- Donnette, M., et al. (2023). "Determination of 5-azacitidine in human plasma by LC-MS/MS: application to pharmacokinetics pilot study in MDS/AML patients." *Cancer Chemotherapy and Pharmacology*. [Link](#)
- Rudek, M. A., et al. (2005). "Clinical Pharmacokinetics of 5-Azacitidine." *Journal of Clinical Oncology*. [Link](#)
- Li, W., et al. (2015). "Quantification of 5-azacytidine in plasma by electrospray tandem mass spectrometry coupled with high-performance liquid chromatography." *Biomedical Chromatography*. [Link](#)
- Derissen, E. J., et al. (2013). "Concise Review: The Role of Cytidine Deaminase in the Disposition and Efficacy of Cytidine Analogs." *The Oncologist*. [Link](#)
- Naim, S., et al. (2020). "AZA-MS: a novel multiparameter mass spectrometry method to determine the intracellular dynamics of azacitidine therapy in vivo." *Nature Communications*. [Link](#)

Need Custom Synthesis?

BenchChem offers custom synthesis for rare earth carbides and specific isotopic labeling.

Email: info@benchchem.com or [Request Quote Online](#).

Sources

- 1. AZA-MS: a novel multiparameter mass spectrometry method to determine the intracellular dynamics of azacitidine therapy in vivo - PMC [[pmc.ncbi.nlm.nih.gov](https://pubmed.ncbi.nlm.nih.gov/)]
- To cite this document: BenchChem. [Advanced Pharmacokinetic Profile Modeling Using 5-Azacytidine-13C4 Tracers]. BenchChem, [2026]. [Online PDF]. Available at: [<https://www.benchchem.com/product/b1160423/docs#advanced-pharmacokinetic-profile-modeling-using-5-azacytidine-13c4-tracers>]

Disclaimer & Data Validity:

The information provided in this document is for Research Use Only (RUO) and is strictly not intended for diagnostic or therapeutic procedures. While BenchChem strives to provide accurate protocols, we make no warranties, express or implied, regarding the fitness of this product for every specific experimental setup.

Technical Support: The protocols provided are for reference purposes. Unsure if this reagent suits your experiment?

Need Industrial/Bulk Grade? [Request Custom Synthesis Quote](#)

BenchChem

Our mission is to be the trusted global source of essential and advanced chemicals, empowering scientists and researchers to drive progress in science and industry.

Contact

Address: 3281 E Guasti Rd
Ontario, CA 91761, United States
Phone: (601) 213-4426
Email: info@benchchem.com

[Contact our Ph.D. Support Team for a compatibility check](#)